

OPERATING INFORMATION

8902A MEASURING RECEIVER

- I GENERAL INFORMATION
- II INSTALLATION
- III OPERATION

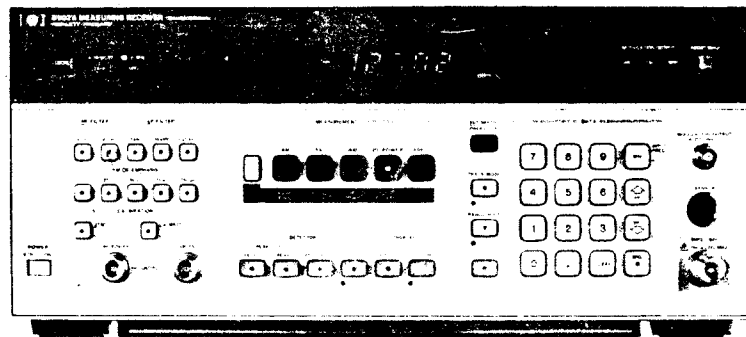

PRELIMINARY

 **HEWLETT
PACKARD**

INDEX (Cont'd)

Tuned RF Level.....	3-75, 3-230
Average.....	3-230
IF Gain.....	3-116
Increased Accuracy.....	3-152
Peak.....	3-139
Relative Level Measurement.....	3-154, 3-75
Synchronous.....	3-230
Tuned RF Level Calibration.....	3-237
Tuned RF Level Calibration Factors.....	3-237
Storage.....	3-124
Default Values.....	3-126
Tuning.....	3-170
UNCAL Annunciator.....	3-240
Wide Filter.....	3-94
ZERO Key.....	3-188
(--).	3-78, 3-83
(----).	3-56, 3-76, 3-78, 3-83, 3-231, 3-239
(-----).	3-78, 3-83, 3-231, 3-240

A-1

8902A MEASURING RECEIVER

SERIAL NUMBERS

This manual applies directly to instruments with serial numbers prefixed 2305A.

For additional important information about serial numbers, see INSTRUMENT COVERED BY MANUAL in Section I.

©HEWLETT-PACKARD COMPANY 1983
EAST 24001 MISSION AVENUE, TAF C-34, SPOKANE, WASHINGTON, U.S.A. 99220

Operating Information Supplement Part No. 08902-90016

Printed: JUNE 1983



**HEWLETT
PACKARD**

INDEX (Cont'd)

Special Function 1.....	3-110, 3-176
Special Function 2.....	3-72
AM.....	3-47
FM.....	3-96
ϕ M.....	3-141
Special Function 3.....	3-94, 3-183
Special Function 4.....	3-230
Special Function 5.....	3-65
Special Function 6.....	3-59
Special Function 7.....	3-164, 3-168
Special Function 8.....	3-80, 3-119, 3-121
Special Function 9.....	3-116
Special Function 10.....	3-184
Special Function 11.....	3-147
Special Function 12.....	3-100
Special Function 13.....	3-53
Special Function 14.....	3-127
Special Function 16.....	3-53
Special Function 17.....	3-100
Special Function 18.....	3-227
Special Function 21.....	3-114
Special Function 22.....	3-204
Special Function 25.....	3-89
Special Function 26.....	3-75
Special Function 27.....	3-111, 3-195
Special Function 29.....	3-207
Special Function 30.....	3-66
Special Function 33.....	3-131
Special Function 34.....	3-118, 3-134
Special Function 35.....	3-182
Special Function 36.....	3-139
Special Function 37.....	3-188, 3-195
Special Function 38.....	3-237
Special Function 39.....	3-237
Special Function 40.....	3-124
Special Function 41.....	3-124
Special Function 49.....	3-152
Special Function 50.....	3-152
Spurious Signals.....	3-123
In the IF.....	3-122
Squelch.....	3-227
STORE Key.....	3-224
Store/Recall.....	3-124, 3-224
Switches, Used in Sensor Modules.....	3-155
Time Base 10 MHz Input.....	3-226
Time Base 10 MHz Output.....	3-226
Tone Burst Receiver.....	3-227
TRACK MODE Key.....	3-170
TTL Output.....	3-113

CERTIFICATION

Hewlett-Packard Company certifies that this product met its published specifications at the time of shipment from the factory. Hewlett-Packard further certifies that its calibration measurements are traceable to the United States National Bureau of Standards, to the extent allowed by the Bureau's calibration facility, and to the calibration facilities of other International Standards Organization members.

WARRANTY

This Hewlett-Packard instrument product is warranted against defects in material and workmanship for a period of one year from date of shipment. During the warranty period, Hewlett-Packard Company will at its option, either repair or replace products which prove to be defective.

For warranty service or repair, this product must be returned to a service facility designated by HP. Buyer shall prepay shipping charges to HP and HP shall pay shipping charges to return the product to Buyer. However, Buyer shall pay all shipping charges, duties, and taxes for products returned to HP from another country.

HP warrants that its software and firmware designated by HP for use with an instrument will execute its programming instructions when properly installed on that instrument. HP does not warrant that the operation of the instrument, or software, or firmware will be uninterrupted or error free.

LIMITATION OF WARRANTY

The foregoing warranty shall not apply to defects resulting from improper or inadequate maintenance by Buyer, Buyer-supplied software or interfacing, unauthorized modification or misuse, operation outside of the environmental specifications for the product, or improper site preparation or maintenance.

NO OTHER WARRANTY IS EXPRESSED OR IMPLIED. HP SPECIFICALLY DISCLAIMS THE IMPLIED WARRANTIES OF MERCHANTABILITY AND FITNESS FOR A PARTICULAR PURPOSE.

EXCLUSIVE REMEDIES

THE REMEDIES PROVIDED HEREIN ARE BUYERS'S SOLE AND EXCLUSIVE REMEDIES. HP SHALL NOT BE LIABLE FOR ANY DIRECT, INDIRECT, SPECIAL, INCIDENTAL, OR CONSEQUENTIAL DAMAGES, WHETHER BASED ON CONTRACT, TORT, OR ANY OTHER LEGAL THEORY.

ASSISTANCE

Product maintenance agreements and other customer assistance agreements are available for Hewlett-Packard products.

For any assistance, contact your nearest Hewlett-Packard Sales and Service Office. Addresses are provided at the back of this manual.

INDEX (Cont'd)

φM.....	3-141
Displayed in Degrees.....	3-144, 3-150
Pulsed.....	3-144
Power Sensor.....	3-238
Transfer Function.....	3-235
Sensor Module.....	3-155
Power-Up.....	3-124
PRE DISPLAY Key.....	3-106
PREVIOUS RATIO Key.....	3-147
Pulse Modulation.....	3-49
RANGE HOLD Key.....	3-145
RATIO Key.....	3-127, 3-147
RECAL Annunciator.....	3-240
RECALL Key.....	3-224
Recorder Output.....	3-152
Reference Calibration Factor.....	3-188, 3-195
Remote Control RF Switch.....	3-155
Residual Noise Effects.....	3-158
RF Amp.....	3-176, 3-181
RF and IF Filters.....	3-94
RF Frequency Error.....	3-164
RF Frequency Resolution.....	3-168
RF Frequency Tuning.....	3-170
RF HP Filter.....	3-94
RF Input Attenuation and Gain.....	3-176, 3-233, 3-241
RF Input Frequency.....	3-179
RF Level.....	3-182
Affects AM Output.....	3-61
RF Power.....	3-184
Increased Accuracy.....	3-152
Measured Without Power Sensor.....	3-182
RF Power Calibration.....	3-188
RF Power Calibration Factors.....	3-195
Stored.....	3-124, 3-195
RF Power Range.....	3-184
RMS Key.....	3-62, 3-63
SAVE CAL Key	
AM Calibration.....	3-53
FM.....	3-100
RF Power.....	3-188
Sensor Module, User-Built.....	3-155
Service Request Condition.....	3-204
SET REF Key.....	3-75
Signal Drift.....	3-237
SINAD.....	3-207
SPCL Key.....	3-209
Special Display.....	3-220
Special Special Display.....	3-220
Special Functions.....	3-209
Cancelled by CALIBRATE key.....	3-58
Disabled by AUTOMATIC OPERATION Key....	3-78

SAFETY CONSIDERATIONS

GENERAL

This product and related documentation must be reviewed for familiarization with safety markings and instructions before operation.

This product is a Safety Class I instrument (provided with a protective earth terminal).

BEFORE APPLYING POWER

Verify that the product is set to match the available line voltage and the correct fuse is installed.

SAFETY EARTH GROUND

An uninterruptible safety earth ground must be provided from the main power source to the product input wiring terminals, power cord, or supplied power cord set.

SAFETY SYMBOLS



Instruction manual symbol: the product will be marked with this symbol when it is necessary for the user to refer to the instruction manual (refer to Table of Contents).



Indicates hazardous voltages



Indicates earth (ground) terminal

WARNING

The WARNING sign denotes a hazard. It calls attention to a procedure, practice, or the like, which, if not correctly performed or adhered to, could result in personal injury. Do not proceed beyond a WARNING sign until the indicated conditions are fully understood and met.

CAUTION

The CAUTION sign denotes a hazard. It calls attention to an operating procedure, practice, or the like, which, if not correctly per-

formed or adhered to, could result in damage to or destruction of part or all of the product. Do not proceed beyond a CAUTION sign until the indicated conditions are fully understood and met.

WARNING

Any interruption of the protective (grounding) conductor (inside or outside the instrument) or disconnecting the protective earth terminal will cause a potential shock hazard that could result in personal injury. (Grounding one conductor of a two conductor outlet is not sufficient protection).

Whenever it is likely that the protection has been impaired, the instrument must be made inoperative and be secured against any unintended operation.

If this instrument is to be energized via an auto-transformer (for voltage reduction) make sure the common terminal is connected to the earth terminal of the power source.

Servicing instructions are for use by service-trained personnel only. To avoid dangerous electric shock, do not perform any servicing unless qualified to do so.

Adjustments described in the manual are performed with power supplied to the instrument while protective covers are removed. Energy available at many points may, if contacted, result in personal injury.

Capacitors inside the instrument may still be charged even if the instrument has been disconnected from its source of supply.

For continued protection against fire hazard, replace the line fuse(s) only with 250V fuse(s) of the same current rating and type (for example, normal blow, time delay, etc.). Do not use repaired fuses or short circuited fuseholders.

INDEX (Cont'd)

Frequency Offset Control.....	3-111
Frequency Stepping.....	3-171
Harmonic Steps, Measuring Frequency.....	3-175
HP FILTER Keys.....	3-91
HP-IB Error Output Format.....	3-84
HP-IB Address.....	3-114
Calibrate vs. Zero Functions.....	3-194
Device Clear.....	3-124
Service Request Condition.....	3-113, 3-127, 3-204
Special Function 40.....	3-126
IF Frequency.....	3-118
IF Gain.....	3-116, 3-230, 3-241
IF Level.....	3-120
IF Output.....	3-122
IF Frequency Response.....	3-94
Image Signals.....	3-173, 3-181
Input Attenuation and Gain.....	3-176
INSTR PRESET Key.....	3-124
kHz \uparrow and kHz \downarrow Keys.....	3-170
Limit.....	3-127
Using Ratio Reference.....	3-150
Linear Display.....	3-147
LO Frequency.....	3-131
LO Input and LO Output.....	3-133
LOG/LIN Key.....	3-147
Logarithmic Display.....	3-147
LP Filter Automatic Selection.....	3-49
LP FILTER Keys.....	3-91
Measurement Resolution.....	3-168
Modulation Output/Audio Input.....	3-135
Calibrated Output.....	3-138
Calibration.....	3-119, 3-119
Impedance.....	3-71, 3-136
Narrow Filter.....	3-94, 3-232
Non-Volatile Memory.....	3-124
Option 002.....	3-226
Option 003.....	3-133
PEAK HOLD Key.....	3-63, 3-64
HP-IB.....	3-64
Peak Tuned RF Level.....	3-139
PEAK+ Key.....	3-62
AM.....	3-49
FM.....	3-99
ϕ M.....	3-144
Frequency Offset Mode.....	3-113
PEAK- Key.....	3-62
AM.....	3-49
FM.....	3-99
ϕ M.....	3-144
Frequency Offset Mode.....	3-113

CONTENTS

Section 1
GENERAL INFORMATION

	Page
Introduction.....	1-1
Specifications.....	1-2
Safety Considerations.....	1-2
Instruments Covered by Manual.....	1-2
Manual Changes Supplement.....	1-3
Description.....	1-3
RF Power.....	1-3
RF Power Calibration.....	1-4
RF Power Calibration Factors.....	1-4
Tuned RF Level.....	1-4
Display Flexibility.....	1-4
RF Frequency Measurements.....	1-4
Modulation Measurements.....	1-4
Post-Detection Audio Filters.....	1-5
Store and Recall.....	1-5
Special Functions.....	1-5
Operation to 42 GHz.....	1-6
Programmability.....	1-6
Options.....	1-6
Electrical Options.....	1-6
Option 001.....	1-6
Option 002.....	1-6
Option 003.....	1-6
Option 004.....	1-6
Mechanical Options.....	1-7
Front Handle Kit (Option 907).....	1-7
Rack Flange Kit (Option 908).....	1-7
Rack Flange and Front Handle Combination Kit (Option 909).....	1-7
Hewlett-Packard Interface Bus (HP-IB).....	1-7
Compatibility.....	1-7
Selecting the HP-IB Address.....	1-8
Accessories Supplied.....	1-8
Electrical Equipment Available.....	1-8
HP-IB Controllers.....	1-8
Sensor Module.....	1-8
Test Source.....	1-8
Service Accessory Kit.....	1-8
Front- to Rear-Panel Connectors Retrofit Kits.....	1-8
Rear- to Front-Panel Connectors Retrofit Kits.....	1-9
High Stability Internal Reference Retrofit Kit.....	1-9
Conversion to 400 Hz Line Operation.....	1-9
Mechanical Equipment Available.....	1-9
Chassis Slide Mount Kit.....	1-9
Chassis Tilt Slide Mount Kit.....	1-9
Recommended Test Equipment.....	1-9
Principles of Operation for Simplified Block Diagram.....	1-10
RF.....	1-10
LO.....	1-12
IF.....	1-12
Audio.....	1-13

INDEX (Cont'd)

CALIBRATE Key	
AM.....	3-53
FM.....	3-100
RF Power.....	3-188
Tuned RF Level.....	3-230, 3-239
Calibration	
AM.....	3-53
FM.....	3-100
RF Power.....	3-188
Tuned RF Level.....	3-237
Calibration Factors	
Automatic.....	3-195
Manual.....	3-195
RF Power.....	3-195
Calibration RF Power Output.....	3-188
Channel Accuracy.....	3-166
dB EXT ATTEN Key.....	3-89
Default Conditions.....	3-124
Disable Error Key.....	3-80
DISPLAY FREQ INCR Key.....	3-170
DISPLAY FREQ Key.....	3-112, 3-195
Display Jitter.....	3-65, 3-54
Down-Converter, Using the IF Output.....	3-122
Error 01.....	3-81
Error 02.....	3-81
Error 03.....	3-81, 3-121, 3-177
Error 04.....	3-74, 3-82, 3-81, 3-99, 3-138
Error 05.....	3-49, 3-99, 3-144
Error 06.....	3-183
Error 10.....	3-113
Error 11.....	3-150
Error 15.....	3-126
Error Message Summary.....	3-83
External Attenuation.....	3-89
External LO.....	3-111, 134
Filters	
Audio.....	3-91
RF and IF.....	3-94
Flatness.....	3-150
FM Accuracy.....	3-49
FM Calibration.....	3-100
FM DE-EMPHASIS.....	3-106
FM Output.....	3-109
FM.....	3-96
Broadcast FM Relative to 75 kHz.....	3-150
Low-Rate, High Deviation.....	3-173
FREQ ERROR Key.....	3-164
FREQ Key.....	3-179
Frequency Comparisons.....	3-164
Frequency Drift, Measuring.....	3-164
Frequency Error, Parts per Million.....	3-167
Frequency Hopping, Measuring Frequency....	3-175, 3-181

CONTENTS (Cont'd)

Section II
INSTALLATION

	Page
Introduction.....	2-1
Initial Inspection.....	2-1
Preparation for Use.....	2-1
Power Requirements.....	2-1
Line Voltage and Fuse Selection.....	2-2
Power Cables.....	2-2
HP-IB Address Selection.....	2-3
Interconnections.....	2-7
Mating Connectors.....	2-8
Interface Connector.....	2-8
Coaxial Connectors.....	2-8
Operating Environment.....	2-8
Bench Operation.....	2-8
Rack Mounting.....	2-8
Removal and Installation of Operating Information	
Pull-Out Cards.....	2-8
Steps for Removal.....	2-8
Steps for Installation.....	2-9
Storage and Shipment.....	2-9
Environment.....	2-9
Packaging.....	2-9
Original Packaging.....	2-9
Other Packaging.....	2-9



Section III
OPERATION

Introduction.....	3-1
General.....	3-1
Operating Characteristics.....	3-1
Turn-On Procedure.....	3-1
Local Operation.....	3-2
Panel Features.....	3-2
Detailed Operating Instructions.....	3-2
Operating Information Pull-Out Cards.....	3-3
Supplemental Information.....	3-3
Remote Operation.....	3-3
Operator's Checks.....	3-3
Basic Functional Checks.....	3-3
HP-IB Functional Checks.....	3-4
Operator's Maintenance.....	3-4
Front-Panel Features.....	3-6
Rear-Panel Features.....	3-8
Operator's Checks.....	3-10
Basic Functional Checks.....	3-10
HP-IB Functional Checks.....	3-18

INDEX

400 Hz DISTN key.....	3-66
1 kHz DISTN key.....	3-66
150 kHz Carrier.....	3-61
455 kHz IF.....	3-94, 3-118, 3-122, 3-232
455 kHz LO.....	3-170
1.5 MHz IF.....	3-118
1.5 MHz LO.....	3-170
50 MHz Power Reference Oscillator.....	3-183
100 MHz LO.....	3-174, 3-181
42 GHz Extended Frequency Range.....	3-111
ALC, AM Demodulator.....	3-48
AM.....	3-47
Displayed as dB down from the Carrier..	3-150
Due to FM.....	3-119
AM Accuracy.....	3-51
AM ALC Response Time.....	3-51
Affects AM Accuracy.....	3-51
Determines Lower Limit of AM Rate.....	3-49
AM Calibration.....	3-53
Default Value.....	3-126
Storage.....	3-124
AM Depth	
Affected by IF Level.....	3-52
Low Modulation Rates.....	3-51
Measured Via AM Output.....	3-59
AM Output.....	3-49, 3-59
Attenuator Measurements.....	3-75
Audio Detector Response.....	3-65
Audio Detectors.....	3-62
Audio Distortion.....	3-66
Audio Filters.....	3-91
Audio Frequency.....	3-70
AUDIO INPUT Key.....	3-66, 3-71
Audio Level.....	3-66
Audio Range.....	3-72
Audio Ranging	
Fixed by Special Function 13.....	3-58
FM.....	3-99, 3-108
AUTO TUNING Key.....	3-170
Automatic Level Control.....	3-120
Automatic Operation.....	3-78
Converse is RANGE HOLD.....	3-79
Disables Front-Panel Keys.....	3-78
Disables Special Functions.....	3-78
AVG (RMS CAL) Key.....	3-62
CAL FACTOR Key	
AM.....	3-53
FM.....	3-100
RF Power.....	3-195
Tuned RF Level.....	3-239

CONTENTS (Cont'd)

	Page
Remote Operation Hewlett-Packard Interface Bus.....	3-31
HP-IB Compatibility.....	3-31
Remote Mode.....	3-31
Remote Capability.....	3-31
Local-to-Remote Mode Changes.....	3-31
Local Mode.....	3-32
Local Capability.....	3-32
Remote-to-Local Mode Changes.....	3-32
Addressing.....	3-32
Local Lockout.....	3-32
Data Messages.....	3-32
Receiving the Data Message.....	3-33
Listen Only.....	3-33
Data Input Format.....	3-33
Program Codes.....	3-34
Turning Off Functions.....	3-34
Programming Numeric Data.....	3-35
Triggering Measurements with the Data Message.....	3-35
Special Considerations for Triggered Operation.....	3-37
Program Order Considerations.....	3-37
Sending the Data Message.....	3-38
Data Output Format.....	3-39
Error Output Format.....	3-39
Timed Displays in Remote Operation.....	3-39
Receiving the Clear Message.....	3-39
Receiving the Trigger Message.....	3-40
Receiving the Remote Message.....	3-40
Receiving the Local Message.....	3-40
Receiving the Local Lockout Message.....	3-41
Receiving the Clear Lockout/Set Local Message.....	3-41
Receiving the Pass Control Message.....	3-41
Sending the Require Service Message.....	3-41
Selecting the Service Request Condition.....	3-42
Sending the Status Byte Message.....	3-42
Sending the Status Bit Message.....	3-43
Receiving the Abort Message.....	3-43
Introduction to Detailed Operating Instructions.....	3-46
Detailed Operating Instructions.....	3-47
AM.....	3-47
AM ALC Response Time.....	3-51
AM Calibration.....	3-53
AM Output.....	3-59
Audio Detectors.....	3-62
Audio Detector Response.....	3-65
Audio Distortion and Level.....	3-66
Audio Frequency.....	3-70
Audio Range.....	3-72
Attenuator Measurements.....	3-75
Automatic Operation.....	3-78
Disable Error Message Control.....	3-80
Error Message Summary.....	3-83
External Attenuation.....	3-89
Filters, Audio.....	3-91

Tuned RF Level Calibration and Calibration Factors (Cont'd)
(Includes Special Functions 38 and 39)

Comments (cont'd)

The input-signal level must remain constant during calibration.

The instrument automatically ranges as shown in the "Synchronous and Average Tuned RF Level Ranges" in "Measurement Technique". Refer to Range Hold for ways to avoid automatic ranging.

Pressing the AUTOMATIC OPERATION or INSTR PRESET key causes the Measuring Receiver to use Automatic Cal Factors (obtained from RF power calibration). Any Manual Cal Factor used during RF power calibration is erased when these functions are initiated, and will not be used in the initial Power Reference Range calibration. (Refer to RF Power Calibration Factors.)

During the calibration procedure, the Measuring Receiver must remain tuned to the input frequency. If the tuned frequency moves more than ± 5 kHz from the frequency at which the power sensor reference was taken, the calibration factors become invalid.

If the input frequency is changed, re-tune the Measuring Receiver, and calibrate the instrument at the new, input frequency. (Refer to RF Frequency Tuning.) The calibration information for the frequency being measured is retained in the Measuring Receiver's non-volatile memory. (Refer to Instrument Preset.)

Each individual calibration factor is tagged with the frequency at which it is valid, and the status of the first three filters in the front of the instrument (Special Function 3). If any of these conditions change, the calibration factor becomes invalid.

If an error is made in entering any calibration factor value with Special Function 39, pressing the CLEAR key allows the user to immediately re-enter the correct value without re-entering the Special Function code.

If calibration has not been performed, or Special Function 39 has not been used to enter any calibration factors, there are no individual calibration factors for any of the ranges. When Special Function 38 is keyed, 0.0% is displayed. When % CAL FACTOR is keyed, an invalid, approximate calibration factor is displayed.

Related Functions

Instrument Preset
Peak Tuned RF Level
RF Power Calibration
RF Power Calibration Factors
Tuned RF Level
Tuned RF Level Calibration and Calibration Factors

CONTENTS (Cont'd)

	Page
Filters, RF and IF.....	3-94
FM.....	3-96
FM Calibration.....	3-100
FM De-emphasis.....	3-106
FM Output.....	3-109
Frequency Offset Control.....	3-111
HP-IB Address.....	3-114
IF Gain.....	3-116
IF Frequency.....	3-118
IF Level.....	3-120
IF Output.....	3-122
Instrument Preset.....	3-124
Limit.....	3-127
LO Frequency.....	3-131
LO Input and LO Output.....	3-133
Modulation Output/Audio Input.....	3-135
Peak Tuned RF Level.....	3-139
ϕ M.....	3-141
Range Hold.....	3-145
Ratio and Log/Lin.....	3-147
Recorder Output.....	3-152
Remote Control RF Switch.....	3-155
Residual Noise Effects.....	3-158
RF Frequency Error.....	3-164
RF Frequency Resolution.....	3-168
RF Frequency Tuning.....	3-170
RF Input Attenuation and Gain.....	3-176
RF Input Frequency.....	3-179
RF Level.....	3-182
RF Power.....	3-184
RF Power Calibration.....	3-188
RF Power Calibration Factors.....	3-195
Service Request Condition.....	3-204
SINAD.....	3-207
Special Functions.....	3-209
Store/Recall.....	3-224
Time Base 10 MHz Input and Time Base 10 MHz Output.....	3-226
Tone Burst Receiver.....	3-227
Tuned RF Level.....	3-230
Tuned RF Level Calibration and Calibration Factors.....	3-237
Index for Section III.....	3-246

Tuned RF Level Calibration and Calibration Factors (Cont'd)
(Includes Special Function 38 and 39)

Measurement Technique (cont'd)

The following table describes the equations used to calculate the actual calibration factors using individual calibration factors:

Power Reference Range: Range used for initial calibration to the power sensor.

CF₁, CF₂, and CF₃: "Individual" calibration factor values for Range: reference to 1, reference to 2, or reference to 3 (respectively).

Power Reference Range	Current Range		
	1	2	3
1	CF ₁	CF ₁ CF ₂	CF ₁ CF ₂ CF ₃
2	$\frac{CF_2}{CF_1}$	CF ₂	CF ₂ CF ₃
3	$\frac{CF_3}{CF_2}$ $\frac{CF_3}{CF_1}$	$\frac{CF_3}{CF_2}$	CF ₃

Only four calibration factors are retained in the instrument's non-volatile memory: Separate calibration factors are maintained for the Power Reference Range of both the IF synchronous and IF average detectors; the calibration factors for subsequent ranges are shared by both detectors.

If no actual calibration factors are available, an approximate calibration factor (accurate within a few dB) is derived.

Comments

If calibration is not possible, perform one of the following procedures:

- o Change the level of the input signal until the RECAL annunciator is displayed.
- o Calibrate the power sensor. (Refer to RF Power Calibration.)
- o Change the IF gain to automatic selection (9.0 SPCL).
- o Change the RF input attenuation and gain to automatic selection (1.0 or 1.9 SPCL).

Approximate calibration factors are designated by the UNCAL annunciator in the display.

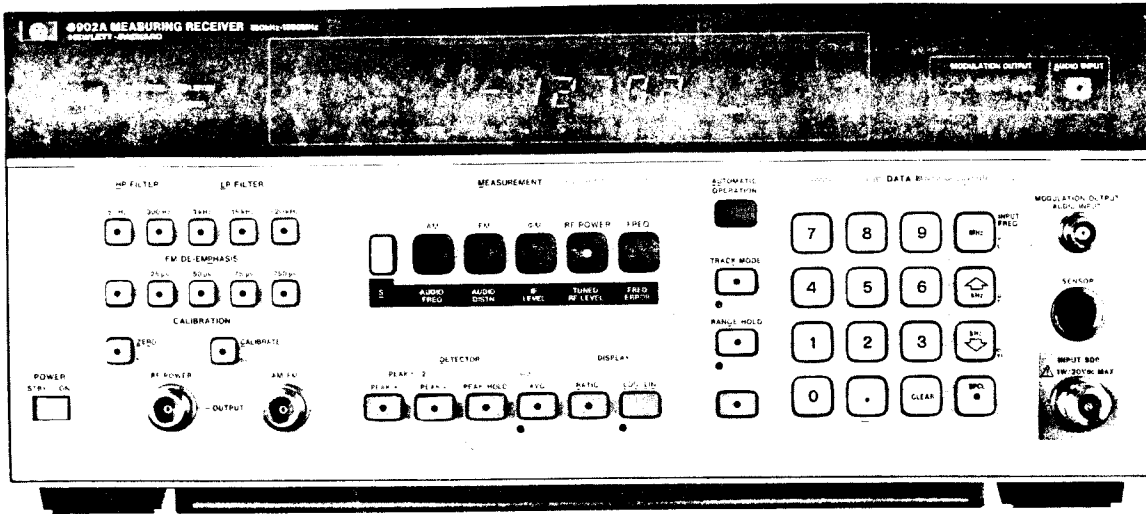

MODEL 8902A

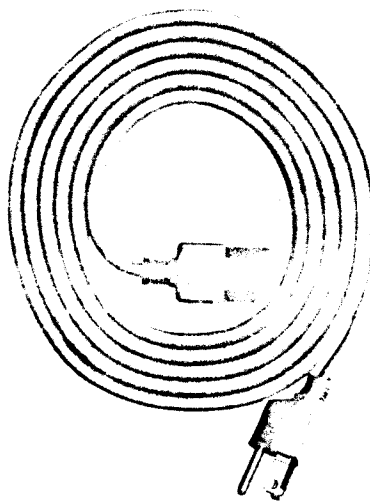

LINE POWER CABLE

Tuned RF Level Calibration and Calibration Factors (Cont'd)
 (Includes Special Functions 38 and 39)

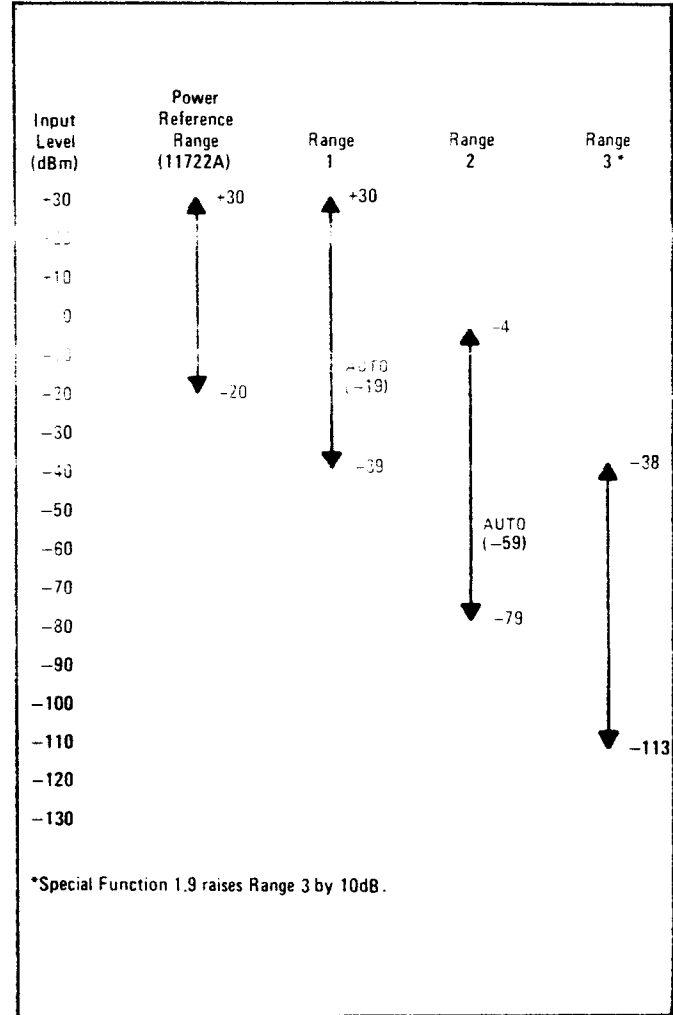
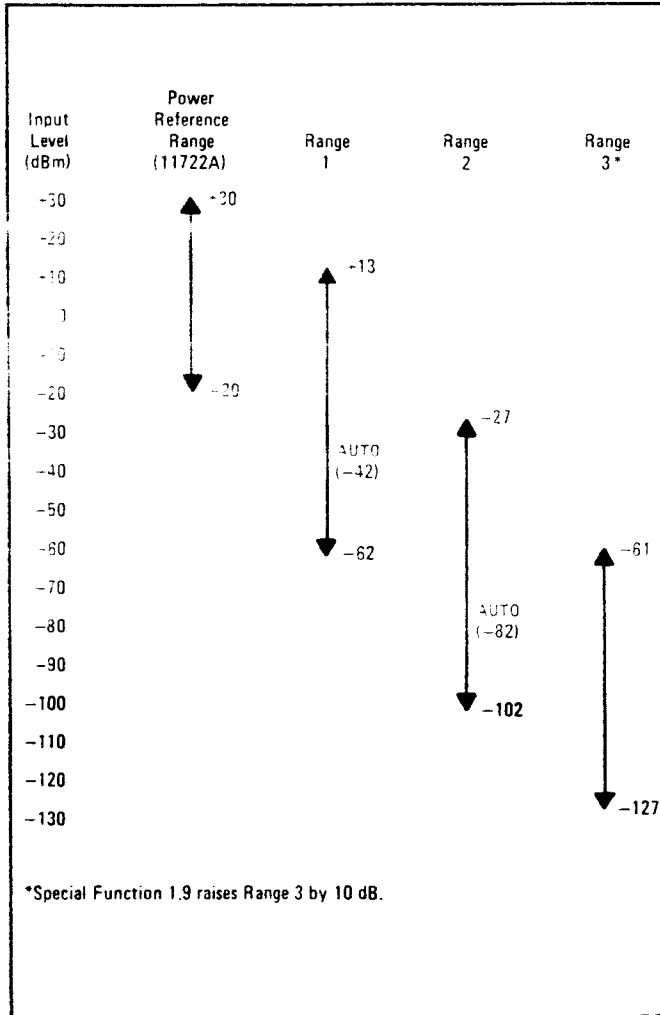

Synchronous Tuned RF Level Ranges

Average Tuned RF Level Ranges

Since the Power Reference Range used with the HP 11722A overlaps both Range 1 and Range 2 in Average Tuned RF Level, it is possible to make the initial calibration against the power sensor on Range 2 instead of Range 1. The calibration factor would be the same as that obtained for Range 2 if initial calibration was performed on Range 1.

An individual calibration factor is computed for each range by comparing the errors obtained during the initial power sensor calibration to those found when calibrating each RF range; but it is combinations of these "individual" calibration factors that create the range-to-range relative calibration factors that are actually used in tuned RF level measurements ("actual" calibration factors). Display the individual calibration factors with Special Function 38. Display the actual calibration factors with the % CAL FACTOR key.

SECTION I GENERAL INFORMATION

1-1. INTRODUCTION

This Operating Information manual and the two Service Information manuals form the Operating and Service Manual which contains information required to install, operate, test, adjust, and service the Hewlett-Packard Model 8902A Measuring Receiver. The Measuring Receiver is shown in Figure 1-1 with all supplied accessories. These manuals document Measuring Receivers supplied with Options 001, 002, 003, and 004.

The information contained in the Operating and Service Manual is made available as follows: Sections I through III are contained in this Operating Information manual, Sections IV through VIII are contained in the two Service Information manuals. The three manuals are packaged in a binder as the Operating and Service Manual.

Section I, General Information: describes the instruments documented by this manual and covers instrument description, options, accessories, specifications and other basic information. This section also contains instrument theory of operation on a simplified block diagram level.

Section II, Installation: provides information about initial inspection, preparation for use (including address selection for remote operation), and storage and shipment.

Section III, Operation: provides information about panel features and includes operating checks, and operating instructions for both local and remote operation.

Section IV, Performance Tests: provides the information required to check performance of the instrument against the critical specifications in Table 1-1.

Section V, Adjustments: provides the information required to properly adjust the instrument.

Section VI, Replaceable Parts: provides ordering information for all replaceable parts and assemblies.

Section VII, Manual Changes: provides manual change information necessary to document all serial prefixes listed on the title page of the second Service Information manual.

Section VIII, Service: provides the information required to repair the instrument.

Tuned RF Level Calibration and Calibration Factors (Cont'd)
(Includes Special Functions 38 and 39)

Measurement Technique (cont'd)

Calibrate the tuned RF level function (as prompted by the UNCAL and RECAL annunciators) by applying a signal to the Measuring Receiver via a calibrated power sensor. The signal must be within the sensor's power and frequency range (but less than +13 dBm). The absolute power is first measured with the calibrated power sensor; the signal is then routed to the RF INPUT connector of the instrument where the level is measured by the IF detector. (If using a power sensor with an internal switch, such as the HP 11722A, the switching is automatic. If using a power sensor alone, reconnect the signal source to the instrument's RF INPUT connector.) The power level, measured by the IF detector, is equated to the power level measured with the power sensor and a calibration factor is created to be used in all subsequent tuned RF level measurements at that frequency.

As the power level of the input signal is varied, the IF amplifier gain is stepped to keep the IF level within the range of the selected IF detector. When the power level approaches the lower limit of the IF range, the RF input attenuation must be reduced. The Calibrate function enables the Measuring Receiver to create a second calibration factor by equating the power level measured before the RF range change with the power level after the change. (The input signal level must not change during this recalibration.) This new calibration factor is factored with the calibration factor made previously (with the power sensor) to be used in all subsequent measurements for that RF range and frequency.

A third recalibration is required if the input signal level approaches the lower limit of the IF detector in the second IF range. This time, RF input gain is added and a third calibration factor is created for that RF range and frequency. The three calibration factors remain in effect as long as the frequency of the input signal is within ± 5 kHz of the initial frequency.

The approximate limits of the three ranges for both the Synchronous and Average Tuned RF Level detectors are shown in the following graphs. The ranging points used in Automatic Operation are also indicated. (The range can be held in a user-specified state. Refer to Range Hold.) The range limits listed for the Power Reference Range apply only for power sensors such as that in the HP 11722A Sensor Module. Other sensors might shift the Power Reference Range up or down.

INTRODUCTION (Cont'd)

Two copies of this Operating Information manual are supplied with the Measuring Receiver. One copy should stay with the Measuring Receiver for use by the operator. Additional copies can be ordered separately through your nearest Hewlett-Packard office. The part number is listed on the title page of this manual.

1-2. SPECIFICATIONS

Instrument specifications are listed in Table 1-1. These are the performance standards, or limits, against which the instrument may be tested. Characteristics listed in Table 1-2, Supplemental Information, are not warranted specifications but are typical characteristics included as additional information for the user.

1-3. SAFETY CONSIDERATIONS

This product is a Safety Class I instrument (i.e., provided with a protective earth terminal). The Measuring Receiver and all related documentation must be reviewed for familiarization with safety markings and instructions before operation. Refer to the Safety Considerations page found at the beginning of this manual for a summary of the safety information.

Safety information pertinent to the task at hand (installation, operation, performance testing, adjustment or service) is found throughout these manuals.

1-4. INSTRUMENTS COVERED BY MANUAL

Options. Electrical options 001, 002, 003, and 004, various mechanical options are documented in these manuals. The differences are noted under the appropriate paragraph such as "Options" in Section I, in the Replaceable Parts List, and in the schematic diagrams.

Serial Numbers. Attached to the instrument is a serial number plate. The serial number is in the form 1234A00123. The first four digits and the letter are the serial prefix. The last five digits form the sequential suffix that is unique to each instrument. The contents of these manuals apply directly to instruments having the same serial number prefix(es) as listed under SERIAL NUMBERS on the respective manual title pages.

For information concerning a serial number prefix not listed on the title page or in the Manual Changes supplement, contact your nearest Hewlett-Packard office.

Tuned RF Level Calibration and Calibration Factors (Cont'd)
(Includes Special Functions 38 and 39)

Indications (cont'd)**When displaying calibration factors:**

Display: When the % CAL FACTOR key is pressed, the value of the calibration factor currently being used is displayed, as well as the % annunciator. The display times out after a few seconds and returns to the previous measurement. The calibration factor displayed is calculated from a combination of individual calibration factors. (Refer to "Measurement Technique" that follows.)

When Special Function 38.1, 2, or 3 is keyed, the value of the individual calibration factor for the selected range pair is displayed, as well as the % annunciator. The individual calibration factor is different than the calibration factor actually being used in the measurement. (Refer to "Measurement Technique".)

Front Panel: Whenever % CAL FACTOR or Special Function 38 is keyed, the LED within the SPCL key is lighted.

Measurement Technique

The tuned RF level measurements use an IF substitution technique to attain a high degree of measurement accuracy over a very wide range of signal levels. Combinations of RF and IF gain keep the signal level within the optimum range for the input mixer, IF amplifiers, and IF detectors:

- The total measurement range of the IF is 75 dB since the instrument's IF has six ranges of IF gain (0 to 60 dB in 10 dB steps), and the IF level detectors are linear over a 15 dB range. The IF gain steps are extremely linear and do not require calibration.
- Three ranges of RF attenuator/gain positions create three ranges of IF gain use. Specified accuracy is obtained when each of the three ranges are calibrated to the absolute power reference (the initial calibration to the power sensor).

The calibrate operations enable the instrument to determine the absolute power level of the low-level signals at one frequency regardless of input losses or variations in frequency response.

High accuracy of relative level measurements is obtained since the range-to-range IF gain steps are very accurate and an initial calibration is performed on each RF range.

1-5. MANUAL CHANGES SUPPLEMENT

An instrument manufactured after the printing of these manuals may have a serial number prefix that is not listed on the title pages. This unlisted serial number prefix indicates the instrument is different from those described in the manual. The Operating and Service Manual is supplied with a Manual Changes supplement for these newer instruments. The supplement contains change instructions for the manual.

In addition to change information, the supplement can contain information for correcting errors in the manual. To keep this manual as current and accurate as possible, Hewlett-Packard recommends that you periodically request the latest Manual Changes supplement. These supplements are identified with the print dates and part numbers that appear on the title page of the Operating and Service Manual. Complimentary copies of these supplements are available from Hewlett-Packard.

1-6. DESCRIPTION

The HP Model 8902A Measuring Receiver is a complete measurement system for accurately characterizing signals in the 150 kHz to 1300 MHz frequency range. It combines the capabilities of four separate instruments in its ability to measure RF power, tuned RF level, carrier frequency, modulation and the characteristics of the demodulated audio signal (as well as those of external audio signals). This flexibility allows you to make those measurements most commonly needed to totally characterize a signal.

The Measuring Receiver can measure an RF signal's frequency, frequency drift, power level, amplitude modulation (AM), frequency modulation (FM), phase modulation (ϕ M), and AM and FM noise components. It recovers the modulating signal and can measure the audio signal's frequency and distortion.

The Measuring Receiver is fully automatic and all major measurements can be made by pushing a single key. The Measuring Receiver's large digital display shows measurement results with excellent resolution and is easy to read. All Measuring Receiver operations can be controlled and all measurement results can be transferred via the Hewlett-Packard Interface Bus (HP-IB). (HP-IB is Hewlett-Packard's implementation of IEEE Standard 488 and ANSI Standard MC1.1.)

RF Power delivers the accuracy and resolution of a high-performance power meter. The HP 8902A, with the HP 11722A Sensor Module, measures power from +30 dBm to -20 dBm at frequencies from 150 kHz to 2.6 GHz. (Refer to Table 1-1, Specifications, for specified frequencies limits using other power sensors. The 8902A also accepts all HP 8480 series power sensors for extended measurement capability.)

The Measuring Receiver is equipped with input power protection to prevent damage from the accidental application of excessive power.

Tuned RF Level Calibration and Calibration Factors (Cont'd)
 (Includes Special Functions 38 and 39)

Indications (cont'd)

Display: Six dashes (-----) will not be displayed if Average (cont'd) Tuned RF Level measurements are selected.

When a measured value is displayed, the selected units annunciator lights, and if the units are linear, the display indicates the measurement in scientific notation; that is, the measured value is followed by a signed, power-of-ten multiplier. The following table shows the annunciator units for linear and logarithmic formats:

Linear Unit	Logarithmic Unit
W	dBm
V	dBV
mV	dB mV
μ V	dB μ V

During calibration:

Display: When the CALIBRATE key is pressed, the measurement annunciator remains in the display for the time required to calibrate the instrument. The display returns to the previous measurement.

If the UNCAL and RECAL annunciators are displayed, the current range is uncalibrated and an attempt can be made at calibration.

When the RECAL annunciator is displayed, and the UNCAL annunciator is not, the displayed power is a calibrated value. The next range can be calibrated at this time since the ranges overlap.

When the UNCAL annunciator is displayed and the RECAL annunciator is not, the current reading is uncalibrated (but approximate) and the current range cannot be calibrated.

When neither the RECAL or UNCAL annunciator is displayed, the measurement is calibrated.

Front Panel: The LED within the CALIBRATE key will light. The LEDs within the S (shift) and the TUNED RF LEVEL keys remain lighted throughout the calibration process.

DESCRIPTION (Cont'd)

(This is a common cause of damage in equipment used to measure transmitters.) The Measuring Receiver is tested for inputs up to 4 watts. Protection is provided by limiting diodes and an RF relay. When excessive power is applied, the relay opens and protects sensitive components, and the Measuring Receiver displays an error message. The circuit automatically resets whenever a key is depressed.

RF Power Calibration is accomplished with the 50 MHz, 1 mW standard available in every instrument. Also, the front-panel zero function enables you to zero the sensor module without removing it from the source-under-test. After the ZERO key is pressed, the new zero offsets are stored automatically.

RF Power Calibration Factors can be entered from the power sensor into the Measuring Receiver's non-volatile memory. The instrument automatically compensates for the power sensor's efficiency and mismatch loss at each frequency.

Tuned RF Level has a minimum sensitivity of -127 dBm with exceptional accuracy. You can also make relative-level measurements with accuracy expected only from a transfer standard.

Display Flexibility enables the Measuring Receiver to offer numerous data-display formats. For example, RF power and tuned RF level can be displayed in watts, dBm, volts, dBV, mv, dBmv, uv, and dBuv. Use the RATIO and LOG/LIN keys to display results in dB or % relative to either a measured value or a value entered from the keyboard. These features eliminate the need for recalculating measurement results.

RF Frequency Measurements. In automatic operation, the Measuring Receiver has the performance of a high-quality, 150 kHz to 1300 MHz frequency counter. The frequency counter automatically adjusts itself as the input level changes. There is no need to manually set or adjust the input attenuator. Because the Measuring Receiver is usually used to measure modulated signals, its frequency counter also accurately measures signals with significant levels of AM.

In automatic operation, the Measuring Receiver automatically tunes to the largest input signal and measures its frequency.

In manual operation, you can determine the frequency to which the Measuring Receiver tunes. Entering the approximate frequency on the keyboard causes all but very close interfering signals to be eliminated. This allows the Measuring Receiver to selectively count signals other than the largest.

A track mode feature enables you to track a signal, as it changes frequency, from either automatic or manual tune operation.

Modulation Measurements. The Measuring Receiver has extremely low, internal noise. Incidental AM, FM, and ϕ M can be measured on a wide range of simple and complex modulated signals. To complement its modulation measurement capability, the HP 8902A characterizes audio signal level, frequency, and distortion.

Tuned RF Level Calibration and Calibration Factors (Cont'd)

(Includes Special Functions 38 and 39)

Procedures (cont'd)

To enter an individual calibration factor, press the keys corresponding to the appropriate Special Function code listed in the previous table. Next, enter the value of the new calibration factor; then press the Blue Key and % CAL FACTOR key.

Example

To enter a Tuned RF Level Calibration Factor of 120% for Range 1:

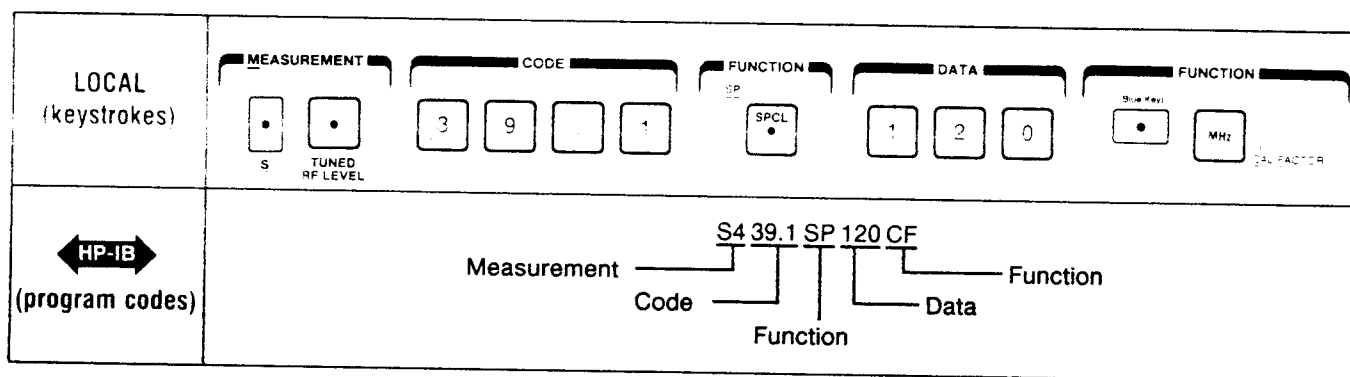

Program Codes

All HP-IB Codes for entering, displaying, or deleting individual calibration factors are provided in "Procedures".

CALIBRATE on = C1
 CALIBRATE off = C0
 % CAL FACTOR = CF
 LIN results = LN
 LOG results = LG
 TUNED RF LEVEL = S4

VOLTS units = VL
 mV units = MV
 uV units = UV
 WATTS units = WT

Indications

Display: When the TUNED RF LEVEL key is pressed, the following responses are displayed: four dashes (----) to indicate the signal has been found, then six dashes (-----) to indicate the instrument is fine tuning to the signal, then four again (----) to indicate settling. If two dashes (--) are displayed, no signal can be found.

DESCRIPTION (Cont'd)

Post-Detection Audio Filters. The Measuring Receiver has two high-pass and three low-pass post-detection audio filters for filtering the recovered modulation. These filters can be selected individually or in combination. Their cutoff frequencies have been chosen to match those needed for applications such as transmitter or signal generator testing. The >20 kHz filter is a Bessel filter. It minimizes overshoot for square-wave modulation so that this type of modulating waveform can also be accurately measured.

The Measuring Receiver contains four de-emphasis networks that can be used in addition to the audio filters. These are the ones commonly used in FM communications -- 25, 50, 75, and 750 μ s. When selected, the de-emphasis networks always affect the demodulated output. You can select whether the de-emphasis network affects the deviation measured. The ability to select either the actual or "de-emphasized deviation" increases the usefulness of the Measuring Receiver in many applications.

Modulation Calibrators are included in every Measuring Receiver. One of the most difficult problems involved in making very accurate measurements of AM depth or FM deviation is generating a precisely modulated signal to use as a calibration standard. In all instruments, a precise AM and FM modulation standard is included.

When the output of the calibrator is connected to the Measuring Receiver's input, the amount of modulation is measured to create a calibration factor. The calibration factor can be used to automatically compensate all subsequent measurements. The calibration factor is the ratio of the measured modulation to the internally-computed modulation of the calibrator, expressed in %.

Store and Recall functions enable you to store eight, complete instrument settings in non-volatile memory and recall them as needed.

Special Functions. The Measuring Receiver can do more than is apparent from the front panel. Many functions are accessed using the numeric keys and a Special Function key. The Special Functions provide access to other measurements and functions, manual control of instrument functions, instrument operation verification, and service aids.

All instrument functions not set using these Special Functions remain in the automatic mode. This allows you to select any combination of manual or automatic operations. By depressing the special key alone, the display shows ten digits that indicate which functions are in automatic and the state of those manually set.

There are also numerous Special Functions that can be used in verifying that the instrument and its various sections are operating properly. These, along with service functions, make diagnosing and repairing the Measuring Receiver faster and easier.

Tuned RF Level Calibration and Calibration Factors (Cont'd)
 (Includes Special Function 38 and 39)

Procedure (cont'd)

Module, or a power sensor and RF switch combination controlled by the instrument's rear panel (refer to Remote Control RF Switch):

- A. Press the S (shift) and TUNED RF LEVEL keys; wait for the measurement value to be displayed. Observe the RECAL annunciator.
- B. Press the CALIBRATE key.

Power Sensor Alone. When using a power sensor with no internal RF switch:

- A. Connect the power sensor from the Measuring Receiver's SENSOR input to the signal source.
- B. Manually key in the frequency of the signal to be tested.
- C. Press the S (shift) and TUNED RF LEVEL keys. Read "--".
- D. Press the CALIBRATE key. Wait until "--" is again displayed.
- E. Disconnect the power sensor from the signal source.
- F. Connect a cable from the Measuring Receiver's RF INPUT to the signal source to complete the calibration procedure.

- 4. Press the CALIBRATE key whenever the RECAL annunciator is displayed.

Display and edit individual calibration factors with Special Functions 38 and 39 (respectively). (Individual calibration factors are used in various combinations to create calibration factors that are used in actual measurements. Refer to the discussion in "Measurement Technique".) The following table lists the Special Function codes that display, enter, and clear individual calibration factors:

Action: Tuned RF Level Calibration Factors	Range	Special Function Code	Program Code ↔ HP-IB ↔
DISPLAY	Reference to 1 Reference to 2 Reference to 3	38.1 SPCL 38.2 SPCL 38.3 SPCL	38.1SP 38.2SP 38.3SP
ENTER	Reference to 1 Reference to 2 Reference to 3	39.1 SPCL 39.2 SPCL 39.3 SPCL	39.1SP 39.2SP 39.3SP
CLEAR	All	39.9 SPCL	39.9SP

DESCRIPTION (Cont'd)

Those Special Functions that are most commonly used in operating the Measuring Receiver are described on the Special Function Information pull-out card under the front panel.

Operation to 42 GHz is accomplished when an external LO and mixer are included in the measurement path. This system then functions as a single instrument making microwave modulation, frequency, power, and level measurements. You control operation from the Measuring Receiver's front panel. When the external LO frequency must be changed, the Measuring Receiver requests the external controller to make the change. A separate, non-volatile calibration factor table is available in Frequency Offset mode for your microwave power sensor.

Programmability. The Measuring Receiver is completely programmable via the Hewlett-Packard Interface Bus (HP-IB). This, coupled with the diversity of measurements the Measuring Receiver can make, the speed with which these measurements can be made, and the flexibility of the Special Functions, make the instrument ideal for systems applications. In many instances it can reduce the number of instruments in a system, speed measurements, reduce complexity and improve accuracy.

When the Measuring Receiver is in remote, the front-panel annunciators make it very easy to determine the state the instrument is in; whether it is in the talk, listen, or service request state.

1-7. OPTIONS**1-8. Electrical Options**

Option 001. This option provides rear-panel (instead of front-panel) connections for RF INPUT, SENSOR input, MODULATION OUTPUT/AUDIO INPUT, and AM/FM and RF POWER CALIBRATION OUTPUTS.

Option 002. This option provides a high-stability (1×10^{-9} /day) internal reference oscillator in place of the standard reference oscillator. In addition, a 10 MHz time base output is provided on the rear panel.

Option 003. This option provides an output for the internal local oscillator signal and an input for external local oscillator signal. Both connections are located on the rear panel and use Type-N connectors.

Option 004. This option allows operation at line frequencies ranging from 48 to 400 Hz. Operation at frequencies greater than 66 Hz is restricted to ≤ 126.5 Vac line input.

Tuned RF Level Calibration and Calibration Factors (Includes Special Functions 38 and 39)

Description

The TUNED RF LEVEL key enables the Measuring Receiver to accurately measure the amplitude of extremely low-level, continuous wave (CW), RF signals at a single frequency.

The instrument first measures the input signal to provide an absolute power reference. As the input-signal level is varied, it can continue to be measured since the IF gain of the instrument is stepped in precise, 10 dB steps. Three, less-precise, internal ranges of RF gain enable the instrument to reach its lowest level measurement capability. Calibration factors, determined for each of these three RF ranges during the actual tuned RF level measurement, correct for RF ranging errors.

Special Functions 38 and 39 provide a way to store, edit, and display calibration factors. Store calibration factors when repeating tuned RF level measurements at many frequencies. (Refer to Store/Recall.) Create and store calibration factors for each frequency, and then recall them as needed for each tuned RF level measurement. Store up to eight sets of calibration factors using the Store/Recall function. Store and recall an unlimited number of sets using an HP-IB controller.

Make tuned RF level measurements using one of two internal detectors: either the narrow-band IF Synchronous Detector Assembly (Synchronous Tuned RF Level measurements), or the wide-band IF average detector in the AM Demodulator Assembly (Average Tuned RF Level measurements). The IF synchronous detector is more sensitive but less tolerant of signal drift and residual FM. The IF average detector is less sensitive but more tolerant of signal drift and residual FM. Each of these Tuned RF Level measurements have different range limits. (See the graphs in "Measurement Technique".)

Procedure

To enable the Measuring Receiver to compute an initial calibration factor to be the absolute power reference for either the Synchronous or Average Tuned RF Level measurement:

1. Calibrate the RF Power function. (Refer to RF Power Calibration.)
2. Ensure that the input signal is in the range required for the power sensor (+30 to -20 dBm for the HP 11722A).
3. Perform the calibration using one of the following procedures:

Power Sensor with an Internal Switch. When using a sensor module that has an internal RF switch, such as the HP 11722A Sensor

1-9. Mechanical Options

The following kits might have been ordered and received with the Measuring Receiver. (See Figure 1-2.) If they were not ordered with the original shipment and are now desired, they can be ordered from the nearest Hewlett-Packard office using the part number included in each of the following paragraphs.

Front Handle Kit (Option 907). Ease of handling is increased with the front-panel handles. Order HP part number 5061-0090 for the basic kit and 2190-0048 for lockwashers (8 required).

Rack Flange Kit (Option 908). The Measuring Receiver can be solidly mounted to the instrument rack using the flange kit. Order HP part number 5061-0078.

Rack Flange and Front Handle Combination Kit (Option 909). This is not a front handle kit and a rack flange kit packaged together; it is composed of a unique part which combines both functions. Order HP part number 5061-0084 for the basic kit and 2190-0009 for lockwashers (8 required).

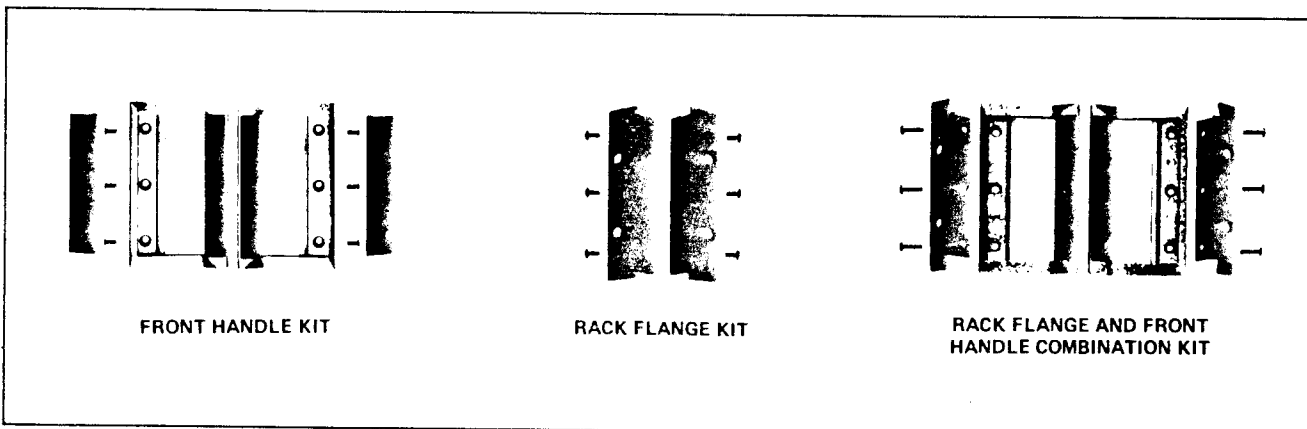

Figure 1-2. Rack-Mounting Options

1-10. HEWLETT-PACKARD INTERFACE BUS (HP-IB)

Compatibility. The Measuring Receiver is compatible with HP-IB to the extent indicated by the following code: SH1, AH1, T5, TE0, L3, LE0, SR1, RL1, PP0, DC1, DT1, C0. The Measuring Receiver interfaces with the bus via open-collector TTL circuitry. An explanation of the compatibility code may be found in IEEE Standard 488, "IEEE Standard and Digital Interface for Programmable Instrumentation" or the identical ANSI Standard MC1.1.

For more detailed information relating to programmable control of the Measuring Receiver, refer to "Remote Operation, Hewlett-Packard Interface Bus" in Section III of this Operating Information manual.

Tuned RF Level (Cont'd)
**(Includes Synchronus and Average Tuned RF Level, and
Special Function 4)**

Comments (cont'd)

Make relative tuned RF level measurements using the SET REF key.
(Refer to Attenuator Measurements.)

Tuned RF Level measurement accuracy can be affected by residual FM on the input signal. If the residual FM is too high (refer to Table 1-1 for specifications), the Average Tuned RF Level Measurement mode can be used.

Related Functions

Attenuator Measurements

Peak Tuned RF Level

RF Power

RF Power Calibration

RF Power Calibration Factors

Tuned RF Level Calibration and Calibration Factors

HEWLETT-PACKARD INTERFACE BUS (HP-IB) (Cont'd)

Selecting the HP-IB Address. The HP-IB address switches are located within the Measuring Receiver. The switches represent a five-bit binary number. This number represents the talk and listen address characters which an HP-IB controller is capable of generating. In addition, two more switches allow the Measuring Receiver to be set to talk only or to listen only. A table in Section II shows all HP-IB talk and listen addresses. Refer to "HP-IB Address Selection" in Section II of this Operating Information manual.

1-11. ACCESSORIES SUPPLIED

The accessories supplied with the Measuring Receiver are shown in Figure 1-1.

- a. The line power cable may be supplied in several plug configurations, depending on the destination of the original shipment. Refer to "Power Cables" in Section II of this Operating Information manual.
- b. Fuses with a 2.5A rating for 115 Vac (HP 2110-0083) and a 1.5A rating for 230 Vac (HP 2110-0043) are supplied. One fuse is factory installed according to the voltage available in the country of original destination. Refer to "Line Voltage and Fuse Selection" in Section II of this Operating Information manual.

1-12. ELECTRICAL EQUIPMENT AVAILABLE

HP-IB Controllers. The Measuring Receiver has an HP-IB interface and can be used with any HP-IB compatible computing controller or computer for automatic systems applications.

Sensor Module. The 11722A Sensor Module enables a single input connector to be used to characterize a signal without switching back and forth between the Measuring Receiver's SENSOR input and RF INPUT connectors. Special care is taken with each sensor module to minimize input SWR and resulting errors. A low SWR attenuator isolates the power sensor from the source-under-test, reducing mismatch. Microwave hardware and a selected RF input cable further improve SWR and insertion loss.

Test Source. The 11715A AM/FM Test Source produces both extremely linear AM and FM at high rates and a low-noise CW signal. This source is required for performance testing and adjusting the Measuring Receiver; however, it is an excellent stand-alone instrument for generating very low distortion FM in the broadcast band.

Service Accessory Kit. A Service Accessory Kit (HP 08901-60089) is available which contains many accessories such as extender boards and cables, useful in servicing the Measuring Receiver.

Front- to Rear-Panel Connectors Retrofit Kits. These kits contain all the necessary components and full instructions for converting

Tuned RF Level (Cont'd)
(Includes Synchronous and Average Tuned RF Level, and Special Function 4)

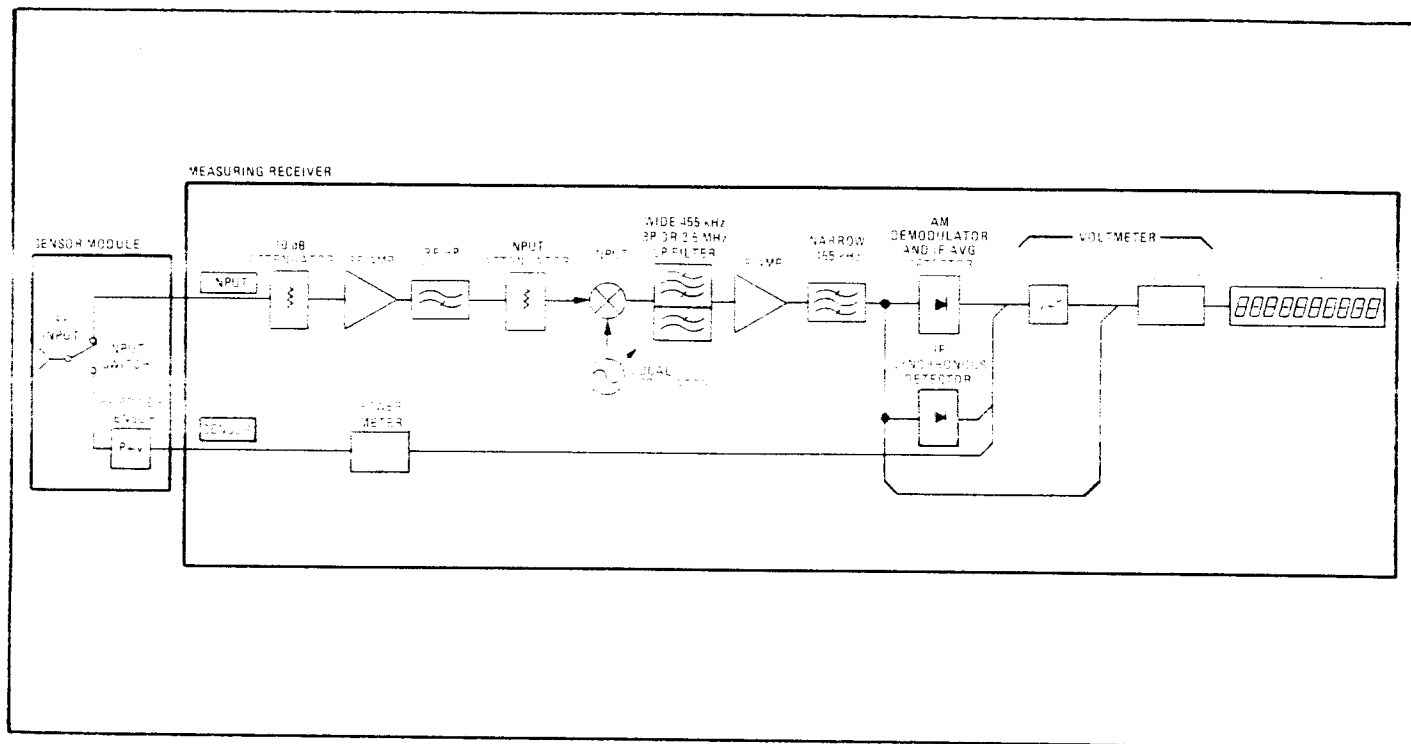

Tuned RF Level Simplified Block Diagram

Comments

The Measuring Receiver must be tuned to the input frequency before valid tuned RF level measurements can be made. If the tuned frequency moves more than ± 5 kHz from the frequency at which the power sensor reference was taken, the instrument must be retuned.

The instrument can be manually tuned to the frequency of interest before or after the TUNED RF LEVEL key is pressed. (Refer to RF Frequency Tuning.)

The Measuring Receiver retains the calibration information for the frequency being measured in its non-volatile memory. (Refer to Instrument Preset.)

For the initial measurement and calibration, set the input signal level to the range required for the power sensor's transfer function to take place; for example, +30 to -20 dBm for the HP 11722A.

Store up to eight frequency/calibration states in memory. (Refer to Store/Recall.)

ELECTRICAL EQUIPMENT AVAILABLE (Cont'd)

instruments with front-panel connections for INPUT, MODULATION OUTPUT/AUDIO INPUT, and AM/FM and RF POWER CALIBRATION OUTPUT to rear-panel connections. Order HP part number 08902-60026. After installation and calibration, performance will be identical to the HP 8902A Option 001.

Rear- to Front-Panel Connectors Retrofit Kits. These kits contain all the necessary components and full instructions for converting Option 001 instruments with rear-panel connections for RF INPUT, SENSOR input, MODULATION OUTPUT/AUDIO INPUT, and AM/FM and RF POWER CALIBRATION OUTPUTS to front-panel connections. Order HP part number 08902-60027. After installation and calibration, performance will be identical to the standard 8902A.

High Stability Internal Reference Retrofit Kit (HP 08902-60028).

This kit contains all the necessary components and full instructions for installation of rear-panel local oscillator connections. After installation and calibration, performance will be identical to the 8902A Option 003.

Conversion to 400 Hz Line Operation. Measuring Receivers not equipped to operate at line power frequencies greater than 66 Hz may be converted to operate at line frequencies from 48 to 440 Hz. However, operation at line frequencies greater than 66 Hz will be restricted to line voltages less than or equal to 126.5 Vac. To convert to 400 Hz operation, order HP part number 08902-60029. After installation, performance will be identical to the 8902A Option 004.

1-13. MECHANICAL EQUIPMENT AVAILABLE

Chassis Slide Mount Kit. This kit is extremely useful when the Measuring Receiver is rack mounted. Access to internal circuits and components or the rear panel is possible without removing the instrument from the rack. Order HP part number 1494-0018 for 431.8 mm (17 in.) fixed slides and part number 1490-0023 for the correct adapters for non-HP rack enclosures.

Chassis Tilt Slide Mount Kit. This kit is the same as the Chassis Slide Mount Kit above except it also allows the tilting of the instrument up or down 90°. Order HP part number 1494-0025 for 431.8 mm (17 in.) tilting slides and part number 1490-0023 for the correct adapters for non-HP rack enclosures.

1-14. RECOMMENDED TEST EQUIPMENT

Table 1-3 lists the test equipment and accessories recommended for use in testing, adjusting, and servicing the Measuring Receiver. If any of the recommended equipment is unavailable, instruments with equivalent minimum specifications may be substituted. Table 1-3 also includes some alternate equipment listings. Table 1-4 lists a number of accessories required in addition to those contained in the Service Accessory Kit, HP 08901-60089.

Tuned RF Level (Cont'd)
(Includes Synchronous and Average Tuned RF Level, and
Special Function 4)

Measurement Technique (cont'd)

Three noise filter bandwidths are available for Tuned RF Level measurements: 10 Hz, 1 Hz, and 0.1 Hz. These bandwidths cause measurement settling times of 0.1s, 1s, and 10s (respectively). The 10 Hz bandwidth is a hardware filter; the other filters are digitally implemented; that is, the readings are mathematically averaged by the controller.

A narrow 455 kHz bandpass filter (30 kHz passband), improves the sensitivity of the measurement at very low levels (where the signal-to-noise ratio is very poor). This filter primarily determines the frequency response for the 455 kHz IF. When this filter is not used, the IF signal bypasses the filter and is routed through a 6 dB attenuator (that matches the filter's passband insertion loss). Special Function 3 controls the IF frequency selection. (Refer to Filters, RF and IF.)

The IF synchronous detector can track the signal over a 10 kHz range by phase locking a 455 kHz voltage-controlled oscillator (VCO) to the IF signal.

The phase-locked loop creates a very narrow bandwidth (150 Hz), which further increases the detector's sensitivity. The instrument's controller monitors the VCO frequency to determine if lock has been acquired. If no signal is sensed, the controller initiates a search routine that sweeps the IF bandwidth. During this search, six dashes (-----) are displayed. If four dashes (----) are displayed after the search, the signal has been found. If two dashes (--) are displayed, no signal can be found. This sweep can take as long as 20 seconds.

Average Tuned RF Level measurements are made the same way that Synchronous Tuned RF Level measurements are made, except that the level amplifier and carrier filter in the AM Demodulator Assembly (rather than the IF synchronous detector) is used to measure the IF level. The wide 455 kHz bandpass filter (200 kHz passband) primarily determines the frequency response for the 455 kHz IF. Special Function 3 controls the IF frequency selection. (Refer to Filters, RF and IF.) The measurement is not phase-locked as it is in the synchronous mode, so the bandwidth of this detector is much wider and enables measurements of noisy or drifting signals.

1-15. PRINCIPLES OF OPERATION FOR SIMPLIFIED BLOCK DIAGRAM

The Measuring Receiver is a calibrated, superheterodyne receiver, which converts the incoming signal to a fixed, intermediate frequency (IF), which is then demodulated. As in a radio receiver, the Measuring Receiver contains an RF amplifier, a local oscillator (LO), a mixer, an IF amplifier and bandpass filter, a demodulator (detector or discriminator), and audio filters (tone controls). The Measuring Receiver, however, contains additional features which make it much more versatile:

- o automatic tuning,
- o selectable measurement mode: signal frequency, power level, or modulation (AM, FM, or Phase Modulation (ϕ M))
- o power level measurements on tuned signals to -127 dBm (0.1 μ V),
- o selectable audio detector (peak, average, or rms responding),
- o audio counter,
- o audio distortion analyzer,
- o measurement calibrators (AM, FM, or power level), and
- o HP-IB programmability.

The entire operation of the instrument is governed by a microprocessor-based Controller. The Controller sets up the instrument at turn-on, interprets keyboard entries, executes changes in internal hardware, and displays measurement results and error messages. The computing capability of the Controller is also used to simplify circuit operation. For example, it forms the last stage of the Counter, calculates the AM or FM generated by the AM and FM Calibrators, and converts measurement results into ratios (in % or dB). The Controller also contains routines useful for servicing the instrument.

RF. The RF input signal normally enters an external Sensor Module such as an HP 11722A. (See Figure 1-3.) For all measurements except RF Power, the Sensor Module routes the signal to the RF input connector of the Measuring Receiver. For the RF Power measurement, the input signal passes directly into the Power Sensor, which converts the RF power absorbed by the RF Power Sensor into a low-frequency, chopped, ac voltage whose amplitude is proportional to the average RF power. The Power Meter amplifies the chopped signal and converts it to a dc voltage which is then measured by the voltmeter. (The voltmeter includes the Audio Peak Detector, Audio Average Detector, Voltage-to-Time Converter, and Counter.) The calibration of the Power Meter can be verified by connecting the Sensor Module to the CALIBRATION RF POWER OUTPUT connector on the front panel. (The 50 MHz Power Reference Oscillator is an accurate 1 mW reference.)

Tuned RF Level (Cont'd)
(Includes Synchronous and Average Tuned RF Level, and Special Function 4)

Measurement Technique (cont'd)

Since the level range of the input signal is usually much greater than the linear range of the IF synchronous detector, the gain of the second IF amplifier (IF Gain - Special Function 9) is set to bring the IF level into the range of the selected detector as the level is changed. The second IF amplifier has high, step-to-step accuracy, but only 60 dB of IF gain is available, so the RF input gain/attenuation (RF Input Attenuation and Gain - Special Function 1) must be switched to enable the instrument to reach its most-sensitive, measurement capability. Three, internal, attenuator/gain positions create three ranges of IF gain use. (See the graphs of Synchronous and Average Tuned RF Level Ranges.)

The three attenuator/gain settings, used to create the three ranges, must each be calibrated to obtain specified accuracy. Tuned RF level calibration takes place during the actual level measurement of each specific frequency being tested.

The following graphs illustrate the approximate limits of the three ranges used for Synchronous and Average Tuned RF Level measurements. Each range is 75 dB due to an IF gain range of 60 dB and a detector range of 15 dB. Each range automatically ranges as specified by "AUTO" in the figures. (The range can be held in a user-specified state. Refer to Range Hold.)

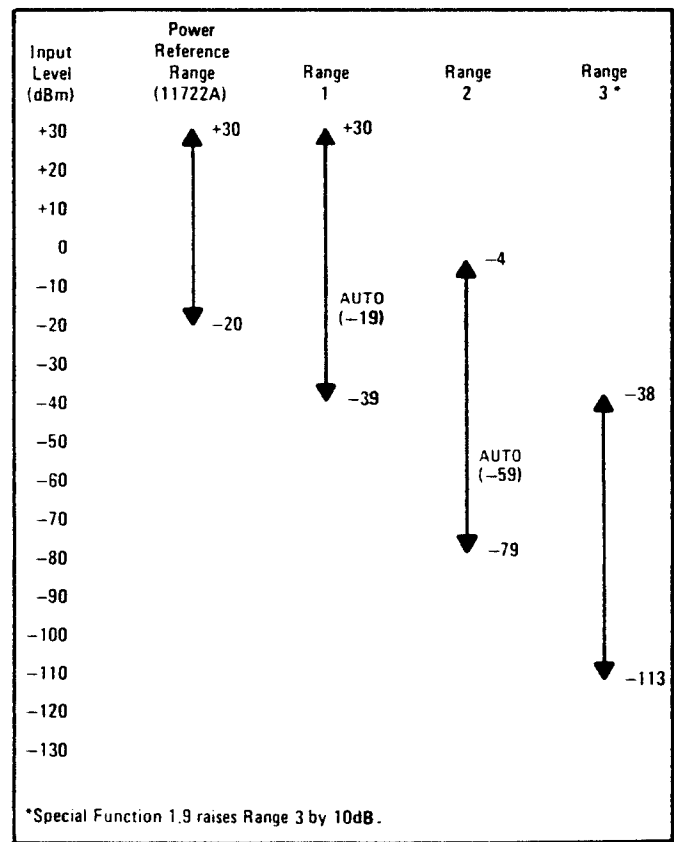
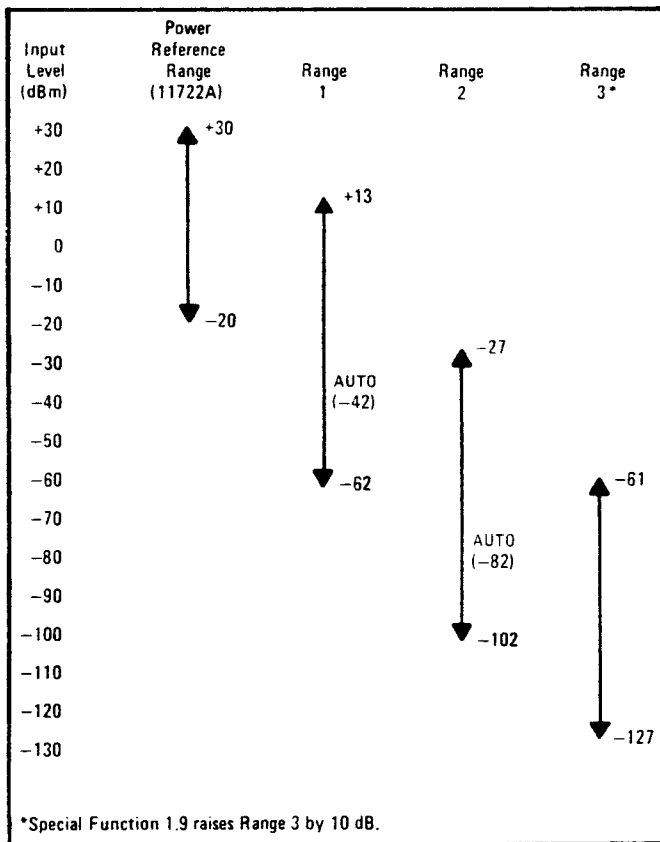

Synchronous Tuned RF Level Ranges

Average Tuned RF Level Ranges

PRINCIPLES OF OPERATION FOR SIMPLIFIED BLOCK DIAGRAM (Cont'd)

CAUTION

The Power Sensor is unprotected against and is easily damaged by sudden, large overloads. Refer to Table 1-2 for information on maximum overload levels.

The broadband, low-noise RF Amplifier improves the sensitivity of the Tuned RF Level measurement. The amplifier is normally bypassed in the other measurement modes.

CAUTION

An RF detector in the RF Amplifier (not shown in Figure 1-3) causes the RF Amplifier to be bypassed when an overload occurs. However, because of the relatively long switching time (approximately 30 ms), the RF Amplifier can be damaged by a large overload. Refer to Table 1-2 for information on maximum overload levels.

When the RF Peak Detector senses that the input signal level exceeds 1W, it opens the Overpower Relay. This is done without intervention of the Controller. The output from the RF Peak Detector, read by the voltmeter, is used to set the Input Attenuator to optimize the level applied to the Input Mixer.

The Input Mixer converts the input signal to the intermediate frequency (IF). For frequencies greater than 10 MHz, the IF is 1.5 MHz with the Local Oscillator (LO) tuned 1.5 MHz above the input frequency, but an IF of 455 kHz can be manually selected for this frequency range. The 455 kHz IF is selected automatically for input signals between 2.5 MHz and 10 MHz and for the Tuned RF Level measurement. Below 2.5 MHz, the input passes directly through the Input Mixer without down-conversion. (The Tuned RF Level measurement is invalid below 2.5 MHz.)

NOTE

For the input signal to pass through the Input Mixer without down-conversion, the LO must still be present to turn the mixer diodes on. An LO frequency of 101.5 MHz is arbitrarily used. Thus the instrument will respond to input frequencies of 100 or 103 MHz as well as frequencies between 150 kHz and 2.5 MHz.

Tuned RF Level (Cont'd)
 (Includes Synchronous and Average Tuned RF Level, and
 Special Function 4)

Indications (cont'd)

Display: When a measured value is displayed, the selected units annunciator lights, and if the units are linear, the display indicates the measurement in scientific notation; that is, the measured value is followed by a signed, power-of-ten multiplier. The following table shows the annunciator units for linear and logarithmic formats:

Linear Unit	Logarithmic Unit
W	dBm
V	dBV
mV	dB mV
μ V	dB μ V

If the tuned RF level range has not been previously calibrated when a measured value is displayed, the UNCAL and RECAL annunciators are displayed. If the UNCAL or RECAL annunciator is displayed, calibrate the tuned RF level measurement. (Refer to Tuned RF Level Calibration and Calibration Factors.)

Front Panel: The LED within the S (shift) and TUNED RF LEVEL keys light.

Measurement Technique

The tuned RF level measurement is calibrated to one frequency ($\pm 5\%$) during the actual measurement. The external power sensor, calibrated during RF power calibration, provides the absolute power reference necessary for absolute tuned RF level calibration. Three internal ranges of RF gain enable the instrument to reach its greatest measurement sensitivity. Calibration factors, determined for each of these three RF ranges during the actual tuned RF level measurement, correct for RF ranging errors. (Refer to Tuned RF Level Calibration and Calibration Factors.)

The Measuring Receiver measures low-level signals using an IF substitution technique. The high-level input signal is down-converted to a 455 kHz IF, amplified, detected by either the IF synchronous detector or IF average detector, and then filtered and measured by the voltmeter circuitry. (See the Tuned RF Level Simplified Block Diagram.)

PRINCIPLES OF OPERATION FOR SIMPLIFIED BLOCK DIAGRAM (Cont'd)

The instrument can be manually tuned to a desired signal even in the presence of larger signals, although filtering may be necessary since low-frequency signals pass directly into the IF. The RF High-Pass Filter can be inserted (via a Special Function) in the RF path for this purpose.

To measure the input frequency, the Counter measures the frequency of the LO and the frequency of the IF from the output of the IF Amplifier and Filter. The Controller computes and displays the difference between the two frequencies. For input frequencies below 2.5 MHz, only the IF is counted, which equals the input frequency.

LO. The LO drives the high-level port of the Input Mixer and is one of several inputs to the Counter. The LO has four main modes of operation:

- tuning to the frequency required to down-convert a signal whose frequency is entered from the keyboard (manual tune mode),
- automatically searching for an input signal, then tuning the LO to the frequency required to down-convert the signal (automatic tune mode),
- automatically searching for an input signal, then configuring the LO in a feedback loop that automatically tracks the signal (automatic tune track mode), and
- tuning to the frequency required to down-convert a signal whose frequency is entered from the keyboard, then configuring the LO in a feedback loop that automatically tracks the input signal (manual tune track mode).

The manual tune track mode is useful when it is desired to follow an unstable signal in the presence of other signals. The non-track modes are used when the LO noise (residual FM) must be minimized.

IF. The gain of the IF Amplifier is fixed except for the Tuned RF Level measurement mode (described below). The IF Filters determine the frequency response of the IF. When the 1.5 MHz IF is selected, the IF filter consists of a 150 kHz to 2.5 MHz bandpass filter (with a nominal center frequency of 1.5 MHz). When the 455 kHz IF is selected, the IF filter is the Wide 455 kHz Bandpass Filter (with a bandwidth of 200 kHz) except for the Tuned RF Level measurement mode where the Narrow 455 kHz Bandpass (with a bandwidth of 30 kHz) is also inserted.

In the Tuned RF Level measurement mode, the signal level is detected by the IF Synchronous Detector, which phase locks to and tracks the IF signal. The narrow bandwidth of the phase lock loop (150 Hz) makes it possible for the detector to measure the signal level even when the signal is buried in noise.

Tuned RF Level (Cont'd)
 (Includes Synchronous and Average Tuned RF Level, and
 Special Function 4)

Procedures (cont'd)

Use the entries in the following table to select the desired measurement averaging times available to either Synchronous or Average Tuned RF Level measurements:

Measurement Averaging Time (s)	Tuned RF Level			
	Synchronous Detector		Average Detector	
	Special Function Code	Program Code ◀HP-IB▶	Special Function Code	Program Code ◀HP-IB▶
AUTO	4.0 SPCL	4.0SP	4.4 SPCL	4.4SP
10	4.1 SPCL	4.1SP	4.5 SPCL	4.5SP
1	4.2 SPCL	4.2SP	4.6 SPCL	4.6SP
0.1	4.3 SPCL	4.3SP	4.7 SPCL	4.7SP

Program Codes ▶HP-IB◀

The HP-IB codes for selecting Synchronous or Average Tuned RF Level measurements are provided in "Procedures".

CALIBRATE on = C1
 CALIBRATE off = C0
 LIN results = LN
 LOG results = LG
 TUNED RF LEVEL = S4

VOLTS units = VL
 mV units = MV
 uV units = UV
 WATTS units = WT

Indications

Display: When the TUNED RF LEVEL key is pressed, the following responses are displayed: four dashes (----) to indicate the signal has been found, then six dashes (-----) to indicate the instrument is fine tuning to the signal, then four again (----) to indicate settling. If two dashes (--) are displayed, no signal can be found.

Six dashes (-----) will not be displayed if Average Tuned RF Level measurements are selected by one of Special Functions 4.4 through 4.7.

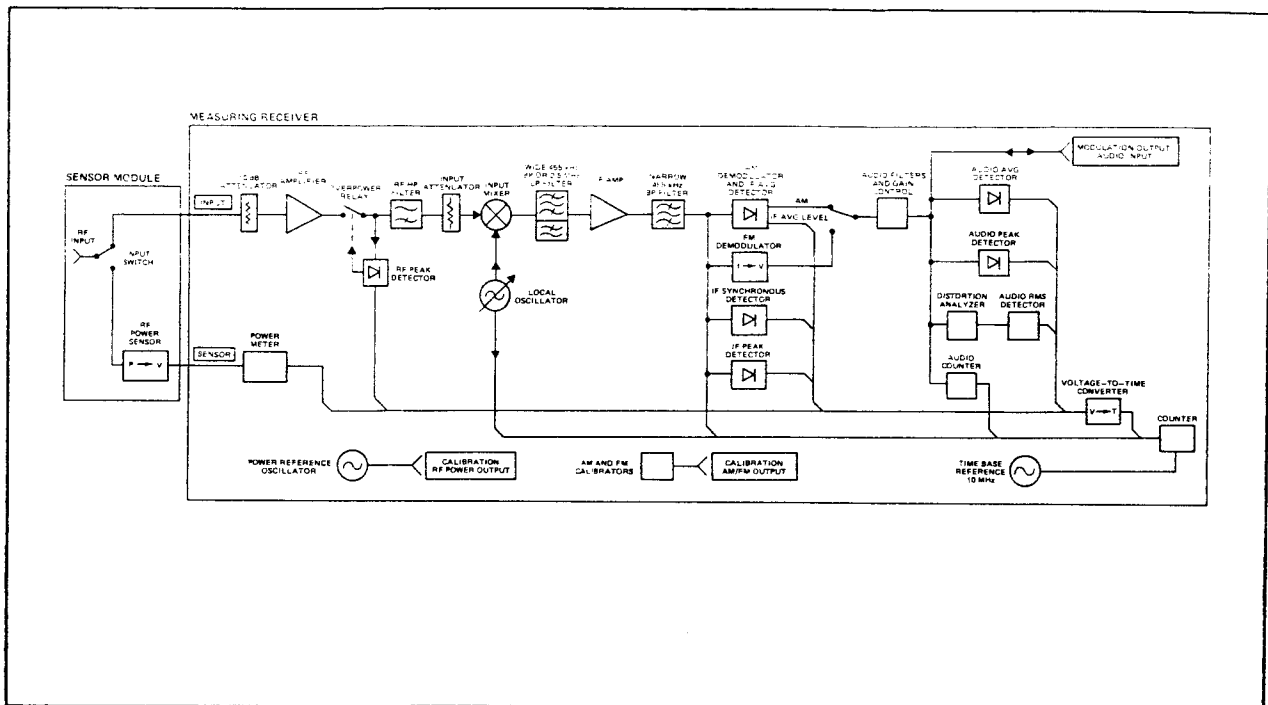

Figure 1-2. HP 8902A Measuring Receiver Simplified Block Diagram

The frequency of the audio signal at the MODULATION OUTPUT/AUDIO INPUT connector, whether internal or external, is measured by a reciprocal-type Audio Counter. In the Audio Counter, the input signal is used to gate the 10 MHz Time Base Reference into the main Counter. (This gating function is also used by the Voltage-to-Time Converter.) The number of time base pulses received during the count is read by the Controller which computes and displays the signal frequency.

The AM and FM Calibrators provide a nominal 10.1 MHz signal with a precisely known amount of AM or FM. When this signal is applied to the instrument's RF INPUT connector (either directly or via the Sensor Module), the modulation is measured and the calibration factor of the AM or FM Demodulator is computed and displayed. Related front-panel functions are automatically set for proper demodulation of the calibrator signal.

Tuned RF Level
(Includes Synchronous and Average Tuned RF Level, and
Special Function 4)

Description

The TUNED RF LEVEL key enables the Measuring Receiver to accurately measure the amplitude of extremely low-level, continuous wave (CW), RF signals at a single frequency. The accuracy of the measurement depends on five factors:

- calibration of the external power sensor,
- calibration of internal circuitry as RF input attenuation or gain is changed,
- accuracy of IF gain steps,
- linearity of the detector being used, and
- SWR mismatch errors.

To make measurements of the highest possible sensitivity on low-noise signals, use the narrow-band IF filter and the IF synchronous detector (Synchronous Tuned RF Level). Select the Synchronous Tuned RF Level Measurement mode with Special Functions 4.0 through 4.3. (The TUNED RF LEVEL key defaults to Special Function 4.0.)

For signals that have significant residual FM, use the wide-band IF filter and the IF average detector in the AM Demodulator (Average Tuned RF Level). This filter and detector combination are less-sensitive than the combination used to make Synchronous Tuned RF Level measurements. Select the Average Tuned RF Level measurement with Special-Functions 4.4 through 4.7.

Table 1-1, "Specifications," lists the measurement sensitivity of these two detectors.

Special Function 4 also selects one of the three measurement averaging times available to both Synchronous and Average Tuned RF Level measurements.

MODULATION OUTPUT/AUDIO INPUT is blanked during tuned RF level measurements.

Procedures

To make a tuned RF level measurement, first tune the instrument to the frequency of interest. (Refer to RF Frequency Tuning.) Press the S (shift) and TUNED RF LEVEL keys and wait for the measurement value to be displayed. If RECAL or UNCAL is displayed, press the CALIBRATE key. (Refer to Tuned RF Level Calibration and Calibration Factors.)

PRINCIPLES OF OPERATION FOR SIMPLIFIED BLOCK DIAGRAM (Cont'd)

To enhance the accuracy of this low-level measurement, the operator must first provide a high-level signal at the desired frequency. (The range of acceptable levels depends on the type of Power Sensor used.) The level is measured by both the Power Meter (which is assumed to be the calibration standard) and the IF Synchronous Detector. From the two power measurements, the Controller computes a calibration factor, which corrects subsequent level measurements made at the same frequency.

Another way of making a tuned RF level measurement is with the IF Average Detector (accessed with Special Function 4), which is part of the AM Demodulator. (Refer to "Tuned RF Level" in the Detailed Operating Instructions of Section III in this Operating Information manual.) Special Function 4). Although somewhat less sensitive than the IF Synchronous Detector, the IF Average Detector has a wider bandwidth, which gives it the ability to make measurements on signals with higher residual FM.

Audio. The modulation on the IF is demodulated by either the AM or the FM Demodulator. Phase modulation is recovered by integrating the demodulated FM in the Audio Filters and Gain Control circuitry.

The demodulated signal is amplified and filtered in the Audio Filters and Gain Control circuitry. The filters are selected from the front panel, and for FM, the filtering may also include de-emphasis. The processed signal is passed to the front-panel MODULATION OUTPUT/AUDIO INPUT connector and the voltmeter.

The audio signal from the Audio Filters and Gain Control is converted to a dc voltage by the Audio Peak Detector or the Audio Average Detector. The Audio Average Detector is used primarily for measuring noise. The output from the detectors is routed into the Voltage-to-Time Converter.

The Voltage-to-Time Converter within the voltmeter converts the dc input into a time interval. During the interval, the 10 MHz Time Base Reference is counted by the Counter, and the resultant count represents the dc voltage. Other inputs to the voltmeter, which are not shown, include outputs from an audio level detector and the AM calibrator.

The Distortion Analyzer measures the distortion of either the internal demodulated signal or an audio signal applied externally to the MODULATION OUTPUT/AUDIO INPUT connector. The frequency of the input signal must be either 1 kHz or 400 Hz. The distortion on the signal is determined by measuring the amplitude of the signal before and after a notch filter that is set to 1 kHz or 400 Hz. The two ac signals are converted to dc by a the Audio RMS Detector and then measured by the voltmeter. Distortion is computed as the ratio of the voltage out of the notch filter to the voltage into the filter. (The Audio RMS Detector can also be used to measure the demodulated AM, FM, or ϕ M internally or the ac level of an external audio signal applied to the MODULATION OUTPUT/AUDIO INPUT connector.)

Tone Burst Receiver (Cont'd) (Special Function 18)

Comments

When using the Tone Burst Receiver Special Function, use the 99 ms delay for best results. Shorter delays require very careful setup since, with no input, the high-gain IF Amplifier and Limiters oscillate at a frequency other than the nominal IF frequency. When RF first enters the instrument, the IF frequency shifts sharply to the nominal frequency. This shift creates an FM transient which settles out after a short period and thus is not apparent with longer delays. With short delays the transients can be avoided by carefully tuning the instrument so that the IF frequency created when the transmitter is keyed is close to, or equal to the IF frequency inherent in the particular instrument's behavior.

This function is best used when operating in remote mode since the counting instrument connected to the output of MODULATION OUTPUT/AUDIO INPUT may need to acquire several sets of data in rapid succession (when counting multiple tones, for example).

Ranges can be held for this function using the individual Special Functions for each parameter instead of using the RANGE HOLD key.

Special Function code 18.0 provides a 99 ms delay.

Related Functions

- Audio Range
- FM
- Range Hold
- RF Frequency Tuning
- RF Input Attenuation and Gain
- Special Functions

Table 1-1. Specifications (1 of 8)

AMPLITUDE MODULATION

Rates:

20 Hz to 10 kHz, $150 \text{ kHz} \leq f_c < 10 \text{ MHz}$.
 20 Hz to 100 kHz, $10 \text{ MHz} \leq f_c \leq 1300 \text{ MHz}$.

Depth: to 99%

Accuracy^{1,2,3}:

AM Accuracy	Frequency Range	Rates	Depths
* $\pm 2\%$ of reading ± 1 digit	150 kHz-10 MHz	50 Hz-10 kHz	5%-99%
$\pm 3\%$ of reading ± 1 digit	150 kHz-10 MHz	20 Hz-10 kHz	to 99%
* $\pm 1\%$ of reading ± 1 digit	10 MHz-1300 MHz	50 Hz-50 kHz	5%-99%
$\pm 3\%$ of reading ± 1 digit	10 MHz-1300 MHz	20 Hz-100 kHz	to 99%

For rms detector add $\pm 3\%$ of readingFlatness^{4,5}:

Flatness	Frequency Range	Rates	Depths
$\pm 3\%$ of reading ± 1 digit	10 MHz-1300 MHz	90 Hz-10 kHz	20%-80%

Demodulated Output Distortion:

$< 0.3\%$ THD for $\leq 50\%$ depth.
 $< 0.6\%$ THD for $\leq 95\%$ depth.

FM Rejection (50 Hz to 3 kHz BW)²:

FM Rejection	Frequency Range	Rates	FM Deviations
$< 0.2\%$ AM	250 kHz-10 MHz	400 Hz or 1 kHz	$< 5 \text{ kHz}_{\text{peak}}$
$< 0.2\%$ AM	10 MHz-1300 MHz	400 Hz or 1 kHz	$< 50 \text{ kHz}_{\text{peak}}$

Residual AM (50 Hz to 3 kHz BW): $< 0.01\%_{\text{rms}}$

Tone Burst Receiver (Cont'd) (Special Function 18)

Procedures

In order to successfully measure tone bursts, tune and range the Measuring Receiver:

1. Select FM.
2. Select a detector, and if desired, filters and de-emphasis.
3. Key on the transmitter and allow the Measuring Receiver to range and tune automatically.
4. Press the RANGE HOLD key to hold all ranges and tuning.
5. Select the time delay to be inserted between the moment the transmitter is keyed and when MODULATION OUTPUT/AUDIO INPUT is to be turned on. This delay becomes the Special Function suffix. (If 18.0 SPCL is selected, the Measuring Receiver executes a 99 ms delay.)
6. Enter the Special Function code 18.NN where NN is the selected delay in milliseconds, then press the SPCL key. (If 18.5 is entered, a 5 ms delay is executed. For a 50 ms delay, enter 18.50.)

The Measuring Receiver is now set up to receive tone bursts. To exit this mode, press any key except the Blue Key, S (shift), numeric, and LOCAL keys.

Program Codes

The Special Function code suffix is derived from the time delay as described in "Procedure".

SPCL = SP

Indications

Display: As the numeric code is entered, it appears on the front panel display. When the SPCL key is pressed, 18.NN is displayed (NN is the delay in milliseconds). If no RF is at the RF INPUT connector, two dashes (--) are displayed.

Front Panel: The LED next to LISTEN in the upper, left portion of the front panel lights.

The LED next to FM in the upper, right portion of the front panel remains lighted signifying that demodulated FM is available at the MODULATION OUTPUT/AUDIO INPUT.

The LEDs within the Measurement, Detector, and Display keys are turned off. Note that if the PRE DISPLAY key was selected, it is also turned off since FM is not being displayed.

Table 1-1. Specifications (2 of 9)

FREQUENCY MODULATION

Rates⁶:

20 Hz to 10 kHz, $150 \text{ kHz} \leq f_c < 10 \text{ MHz}$.
 20 Hz to 200 kHz, $10 \text{ MHz} \leq f_c \leq 1300 \text{ MHz}$.

Deviations⁶:

40 kHz_{peak} maximum, $150 \text{ kHz} \leq f_c < 10 \text{ MHz}$.
 400 kHz_{peak} maximum, $10 \text{ MHz} \leq f_c \leq 1300 \text{ MHz}$.

Accuracy^{1,2,6}:

FM Accuracy	Frequency Range	Rates	Deviations
+2% of reading +1 digit	250 kHz-10 MHz	20 Hz-10 kHz	$\leq 40 \text{ kHz}_{\text{peak}}$
+1% of reading +1 digit	10 MHz-1300 MHz	50 Hz-100 kHz	$\leq 400 \text{ kHz}_{\text{peak}}$
+5% of reading +1 digit	10 MHz-1300 MHz	20 Hz-200 kHz	$\leq 400 \text{ kHz}_{\text{peak}}$

For rms detector add $\pm 3\%$ of reading.

Demodulated Output Distortion^{6,7}:

THD	Frequency Range	Rates	Deviations
<0.1%	400 kHz-10 MHz	20 Hz-10 kHz	<10 kHz
<0.1%	10 MHz-1300 MHz	20 Hz-100 kHz	<100 kHz

AM Rejection (50 Hz to 3 kHz BW)²:

AM Rejection	Frequency Range	Rates	AM Depths
<20 Hz peak deviation	150 kHz-1300 MHz	400 Hz or 1 kHz	$\leq 50\%$

Residual FM (50 Hz to 3 kHz BW):

<8 Hz_{rms} at 1300 MHz, decreasing linearly with frequency to
 <1 Hz_{rms} for 100 MHz and below.

Tone Burst Receiver (Special Function 18)

Description

In some FM applications (mobile radio, for example), after a transmitter is keyed, it issues squelch tones for a brief interval. Often, it is necessary to measure the frequency of the squelch tones. It is difficult to measure this frequency due to the audio noise present in the demodulated signal that occurs in the short delay between the keying of the transmitter and the appearance of the tones.

Special Function 18 enables the Measuring Receiver to be configured as a tone burst receiver. This function inserts a user-selectable delay between the instant the instrument senses an RF signal at its RF INPUT and the time when it turns on the output of MODULATION OUTPUT/AUDIO INPUT. Only the valid audio tone can reach the external counter on a repeatable basis. The time delay is selectable from 1 through 99 milliseconds. The photo in the following figure illustrates a 99 ms delay between transmitter keying (lower trace).

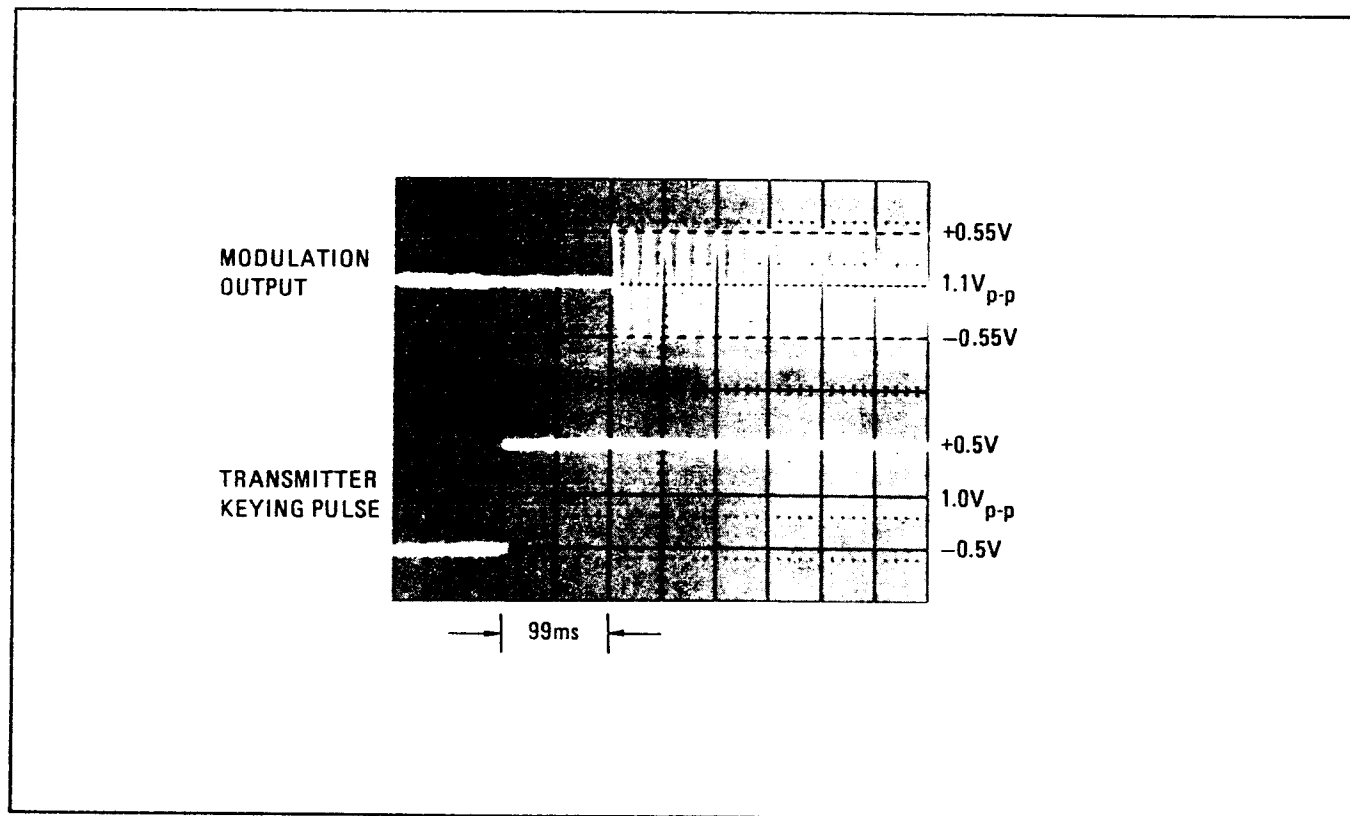

Oscilloscope Photo Depicting a 99 ms Delay Between
Transmitter Keying Pulse (Lower Trace) and
Activation of MODULATION OUTPUT/AUDIO INPUT

Table 1-1. Specifications (3 of 9)

PHASE MODULATION

Rates:

200 Hz to 10 kHz, $150 \text{ kHz} \leq f_c < 10 \text{ MHz}$.

200 Hz to 20 kHz, $10 \text{ MHz} \leq f_c \leq 1300 \text{ MHz}$.

Accuracy²:

+4% of reading +1 digit, $150 \text{ kHz} \leq f_c < 10 \text{ MHz}$.

+3% of reading +1 digit, $10 \text{ MHz} \leq f_c \leq 1300 \text{ MHz}$.

For rms detector add +3% of reading.

Demodulated Output Distortion: <0.1% THD.

AM Rejection (for 50% AM at 1 kHz Rates)²:

<0.03 radians peak (50 Hz to 3 kHz BW).

Maximum Deviation, Resolution, and Maximum Demodulated Output Sensitivity Across an Open Circuit (600 ohms Output Impedance)⁵:

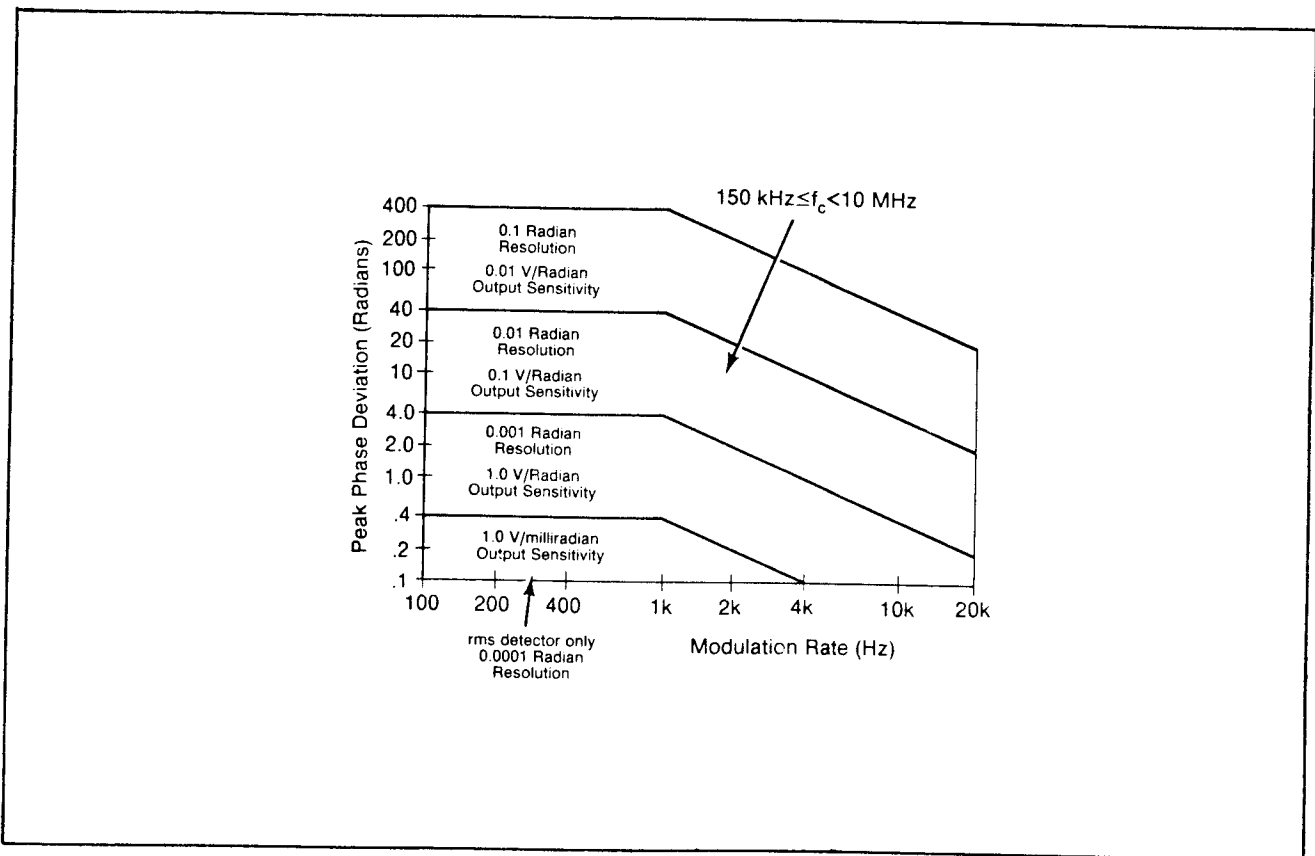

MODULATION REFERENCE

AM Calibrator Depth and Accuracy:

33.33% depth nominal, internally calibrated to an accuracy of +0.1%.

FM Calibrator Deviation and Accuracy:

34 kHz_{peak} deviation nominal, internally calibrated to an accuracy of +0.1%.

Time Base 10 MHz Input and Time Base 10 MHz Output

CAUTION

Do not apply greater than 20V peak (ac + dc) into the TIME BASE 10 MHz INPUT or damage to the instrument may result.

Do not apply greater than 3 Vdc or greater than +20 dBm into the TIME BASE 10 MHz OUTPUT or damage to the instrument may result.

Description

TIME BASE 10 MHz INPUT provides an input for an external 10 MHz time base reference. This input is ac coupled and requires an input signal level greater than 0.5 Vp-p. The input impedance is approximately 500 ohms.

TIME BASE 10 MHz OUTPUT (available only with the high stability reference, Option 002) provides an output for the internal 10 MHz reference. The output is a 50 ohm, TTL compatible output (0V to greater than 2.2V into an open circuit).

Comments

An Option 002 (high stability reference) Measuring Receiver, that is driven from an external reference, will only output the signal from its own internal reference, not the external input signal.

When using an external time base reference, the accuracy of all measurements depends on the accuracy of the external reference.

When an external time base of sufficient amplitude is applied, the Measuring Receiver time base circuitry automatically switches to the external time base.

If the internal time base fails, an external time base may still be used. Connect the external time base to TIME BASE 10 MHz INPUT, then switch the instrument's POWER switch to STBY and back to ON.

To drive several instruments from a single external reference, simply use a BNC tee at the Measuring Receiver's TIME BASE 10 MHz INPUT.

To determine whether the Measuring Receiver has actually switched in the externally applied time base, key in 46.9 SPCL. The display should show 1 000 000 ± 1 if the external time base is in. If the external signal was not switched in, the display will show 0 or 1 only.

Table 1-1. Specifications (4 of 9)

FREQUENCY COUNTER

Range: 150 kHz to 1300 MHz.

Sensitivity:

12 mV_{rms} (-25 dBm), 150 kHz $\leq f_c \leq$ 650 MHz.

22 mV_{rms} (-20 dBm), 650 MHz $< f_c \leq$ 1300 MHz.

Maximum Resolution: 10 Hz

Accuracy: ± 3 counts of least-significant digit \pm Reference accuracy.

INTERNAL TIME BASE REFERENCE

Frequency: 10 MHz

Aging Rate:

$< 1 \times 10^{-6}$ /month

$< 1 \times 10^{-9}$ /day (Option 002)⁸

RF POWER

The HP 8902A Measuring Receiver, with HP 11722A Sensor Module, performs RF Power Measurements from -20 dBm (10 μ W) to +30 dBm (1W) at frequencies from 100 kHz to 2.6 GHz. The 8902A can be used with any of the HP 8480 series power sensors (8481A/1B/1H/2A/2B/2H/3A/4A/5A) to make power measurements from -70 dBm (10 pW) to +44 dBm (25W) at frequencies from 100 kHz to 26.5 GHz. The 8480 series sensors also work with the HP 435A and HP 436A Power Meters. Unless otherwise specified, the specifications shown below refer to the 8902A only. A detailed explanation of how the uncertainty specifications provided below affect the absolute power measurement accuracy of the 8902A is provided in Application Note 64-1.

RF Power Resolution⁹:

0.1% of full scale in watts or volts mode.

0.01 dB in dBm or dB_{relative} mode.

Linearity (includes sensor non-linearity):

RF range linearity \pm RF range-to-range change error.

RF Range Linearity (using Recorder Output)¹⁰:

± 0.02 dB, RF Ranges 2-5.

± 0.03 dB, RF Range 1.

Using front-panel display add ± 1 count of least-significant digit.

RF Range-to-Range Change Error (using Recorder Output):

± 0.02 dB/RF Range change from reference range. Using front-panel display add ± 1 count of least-significant digit.

Input SWR: < 1.15 , using 11722A Sensor Module.

Zero Set (Digital Settability of Zero):

$\pm 0.07\%$ of full scale on lowest range.

Decrease by a factor of 10 for each higher range.

Store/Recall (Cont'd)

RF level measurement, recalibration is unnecessary. (Refer to Tuned RF Level.)

Related Functions

Instrument Preset

Table 1-1. Specifications (5 of 9)

POWER REFERENCE**Power Output:**

1.00 mW. Factory set to $\pm 0.7\%$, traceable to the U.S. National Bureau of Standards.

Accuracy: $\pm 1.2\%$ worst case ($\pm 0.9\%$ rss) for one year (0°C to 55°C).

TUNED RF LEVEL**Power Range:**

-127 dBm to 0 dBm, using IF synchronous detector (200 Hz BW).

-100 dBm to 0 dBm, using IF average detector (30 kHz BW).

Frequency Range: 2.5 MHz to 1300 MHz.

Displayed Resolution¹¹:

4 digits in watts or volts mode.

0.01 dB in dBm or dB_{relative} mode.

Relative Measurement Accuracy (at Constant Temperature and After RF Range Calibration is Completed)¹²:

Detector Linearity + IF Range-to-Range error + RF Range-to-Range + Frequency Drift Error + Noise Error ± 1 digit.

Detector Linearity:

± 0.01 dB, IF synchronous detector.

± 0.02 dB, IF average detector.

IF Range-to-Range Error (see Tuned RF Level Range Plot)¹³:

± 0.02 dB/IF Range change, IF Ranges 1 through 5.

± 0.05 dB/IF Range change, IF Ranges 6 and 7.

RF Range-to-Range Error:

± 0.04 dB/RF Range change (tuned RF level only).

± 0.06 dB/RF Range change, RF power to tuned RF level.

Frequency Drift Error:

± 0.05 dB/kHz frequency drift from center of IF.

Noise Error:

± 0.18 dB, using IF synchronous detector, and for levels < -120 dBm, or for levels < -110 dBm if Special Function 1.9 is implemented.

Input SWR:

< 1.18 , at 8902A RF Input, RF Range 1, 2.

< 1.40 , at 8902A RF Input, RF Range 3.

< 1.33 , at 11722A RF Input, RF Range 1, 2.

< 1.50 , at 11722A RF Input, RF Range 3.

< 1.33 , at 11722A RF Input, RF Range 3 with Special Function 1.9.

Store/Recall

Description

The STORE key enables the Measuring Receiver to store a complete instrument state (including all front-panel functions and most Special Functions) in any of its eight storage registers. Any of these stored states can then be re-initiated using the RECALL key.

Procedures

To store the current instrument state, press the Blue Key and the STORE (7) key. Then enter a register number (1-8).

To recall a previously-stored instrument state, press the Blue Key and the RECALL (8) key. Then enter the appropriate register number (1-8).

HP-IB Program Codes

RECALL = RC

STORE = TR

Indications

Display: When the Blue Key, STORE key, and storage register number are pressed, the display blanks briefly. After each key is pressed, the display returns to the measurement previously selected.

After the RECALL key is pressed, the display blanks briefly. A measurement is then made on the current input signal with the instrument set to the state existing in the selected storage register.

Front Panel: The STORE key does not affect the LEDs within the front-panel keys.

When the RECALL key is pressed, the LEDs within the appropriate keys light.

Comments

Regarding storage of RF power calibration factors:

- The current reference calibration factor and the frequency/calibration factor pair can be stored.
- Manual calibration factors can be stored.
- The table of calibration factors cannot be stored with this function, but two tables of calibration factors can be separately stored in the instrument's non-volatile memory. (Refer to RF Power Calibration Factors.)

If the input frequency has changed when a previously-stored state is recalled, the Measuring Receiver will retune. If this recalled state includes a tuned RF level measurement, the instrument must be recalibrated. If frequency stays the same upon returning to a tuned

Table 1-1. Specifications (6 of 9)

AUDIO FREQUENCY COUNTER

Frequency Range: 20 Hz to 250 kHz. (Usable to 600 kHz.)

Maximum External Input Voltage: $3V_{rms}$.

Accuracy (For Demodulated Signals)¹⁴:

Accuracy	Frequency	Modulation (Peak)
± 3 counts of least-significant digit + Internal Reference Accuracy	>1 kHz	AM $\geq 10\%$ FM ≥ 1.0 kHz $\phi M \geq 1.5$ radians
± 0.02 Hz + Internal Reference Accuracy	≤ 1 kHz	AM $\geq 10\%$ FM ≥ 1.0 kHz $\phi M \geq 1.5$ radian
± 0.2 Hz + Internal Reference Accuracy (3 kHz low-pass filter inserted)	≤ 3 kHz	$1.5\% \leq AM < 10\%$ $0.15 \text{ kHz} \leq FM < 1.0 \text{ kHz}$ $0.15 \text{ radian} \leq \phi M < 1.5$ radian

Accuracy (For External Signals)¹⁴:

± 3 counts of least-significant digit + Internal Reference	>1 kHz	$\geq 100 \text{ mV}_{rms}$
± 0.02 Hz + Internal Reference Accuracy	<1 kHz	$\geq 100 \text{ mV}_{rms}$

AUDIO DISTORTION

Fundamental Frequencies: 400 Hz $\pm 5\%$ and 1 kHz $\pm 5\%$

Maximum External Input Voltage: $3V$.

Display Range: 0.01% to 100.00% (-80.00 dB to 0.00 dB).

Displayed Resolution: 0.01% or 0.01 dB.

Accuracy: ± 1 dB of reading.

Sensitivity:

Modulation:

0.15 kHz peak FM, 1.5% peak AM or 0.6 radian peak ϕM .

External: 100 mV_{rms}

Residual Noise and Distortion¹⁵:

0.3% (-50.4 dB), temperature $<40_{\circ}C$.

Special Functions (Cont'd)

Comments

If a Special Function has a suffix of zero, the zero need not be entered. For example, 10.0 SPCL equals 10.SPCL. (However, 22.2 SPCL does not equal 22.20 SPCL nor does 18.1 SPCL equal 18.10 SPCL.) If when entering a Special Function code, Error 21 (invalid key sequence) is displayed, the Special Function requested has not been executed.

In most cases, the user-selected Special Function suffix appears in both the Special Display and the Special Special Display. However, Special Functions 1.9 and 4.4 are user-selected, automatic-selection modes, and display a different suffix in the Special Special Display.

Related Functions

Instrument Preset

Special Function Summary table (in "Description" of this instruction)

Table 1-1. Specifications (7 of 9)

AUDIO RMS LEVEL

Frequency Range: 50 Hz to 40 kHz.
 Voltage Range: 100 mV to 3V.
 Accuracy: $\pm 4.0\%$ of reading

AUDIO FILTERS

De-emphasis Filters: 25 μ s, 50 μ s, 75 μ s, and 750 μ s.
 De-emphasis filters are single-pole, low-pass filters with 3 dB frequencies of: 6366 Hz for 25 μ s, 3183 Hz for 50 μ s, 2122 Hz for 75 μ s, and 212 Hz for 750 μ s.
 50 Hz High-Pass Filter (2 Pole):
 Flatness: $< 1\%$ at rates > 200 Hz.
 300 Hz High-Pass Filter (2 Pole):
 Flatness: $< 1\%$ at rates > 1 kHz.
 3 kHz Low-Pass Filter (5 Pole):
 Flatness: $< 1\%$ at rates ≤ 1 kHz.
 15 kHz Low-Pass Filter (5 Pole):
 Flatness: $< 1\%$ at rates ≤ 10 kHz.
 > 20 kHz Low-Pass Filter (9 Pole Bessel)¹⁶:
 Flatness: $< 1\%$ at rates ≤ 10 kHz.

RF INPUT

Frequency Range: 150 kHz to 1300 MHz.
 Operating Level:

Minimum Operating Level	Maximum Operating Level	Frequency Range
12 mV _{rms} (-25 dBm)	7 V _{rms} (1W _{peak}) Source SWR < 4	150 kHz-650 MHz
22 mV _{rms} (-20 dBm)	7 V _{rms} (1W _{peak}) Source SWR < 4	650 MHz-1300 MHz

GENERAL SPECIFICATIONS

Temperature: Operating: 0°C to 55°C.
 Storage: -55°C to 75°C.
 Remote Operation: HP-IB; all functions except the line switch are remotely controllable.
 HP-IB Compatibility: (Defined in IEEE 488-1978) SH1, AH1, T5, TE0, L3, LEO, SR1, RL1, PP0, DC1, DT1, C0, E1.

Special Functions (Cont'd)

Procedures (cont'd)

This display is interpreted as follows:

Special Function		Actual Instrument Setting
Code	Name	
1.2	RF Input Attenuation and Gain	10 dB Attenuation
2.1	Audio Range	40% AM; 4 kHz FM; 4 radians ϕ M
3.2	RF and IF Filters	1.5 MHz IF Frequency; 2.5 MHz IF Bandwidth; Narrow Filter Out; RF High-Pass Filter Out
4.2	Tuned RF Level Detector Selection and Display Averaging	If Synchronous Detector with 1 Second Averaging Time
5.0	Audio Detector Response	Fast Response
6.1	Automatic Level Control	Fast Response
7.2	RF Frequency Resolution	100 Hz
8.8	Error Message Disable	All Errors Enabled
9.2	IF Gain	10 dB IF Gain
10.1	RF Power Range	Range #1

 Program Code

SPCL = SP

Indications

Entering Special Functions.

Display: As the numeric code is entered, it appears on the display. When the SPCL key is pressed, the display shows the measurement result or the information requested, or, if none has been requested, the display returns to the measurement previously selected.

Front Panel: Most Special Functions with a non-zero suffix will turn on the LED within the SPCL key. (Refer to the Special Function Summary for exceptions.)

Table 1-1. Specifications (8 of 9)

GENERAL SPECIFICATIONS (Cont'd)

EMI: Conducted and radiated interference is within the requirements of methods CE03 and RE02 of MIL STD 461A (for inputs <10 mW), VDE 0871 (Level B), and CISPR publication 11.

Conducted and Radiated Susceptibility: Meets the requirements of methods CS01, CS02, and RS03 (1 volt/meter) of MIL STD 461A dated 1968.

Power: 100, 120, 220, or 240V (+5%, -10%); 48-66 Hz; 200 VA maximum.

Weight: Net 23 kg. (52 lb.); Shipping 31.4 kg. (69 lb.).

Dimensions: 190 mm. H x 425 mm. W x 468 mm. D
(7.5" x 16.8" x 21.7").

HP System II Module Size: 7 H x 1 MW x 20 D.

FOOTNOTES

- 1 But not to exceed: 50 Hz to 40 kHz rates with rms detector for stated accuracy.
- 2 Peak residuals must be accounted for in peak readings.
- 3 For peak measurements only; AM accuracy may be affected by distortion generated by the Measuring Receiver. In the worst case this distortion can decrease accuracy by 0.1% of reading for each 0.1% of distortion.
- 4 Flatness is the variation in indicated AM depth for constant depth on input signal.
- 5 For optimum flatness, cables should be terminated with their characteristic impedance.
- 6 But not to exceed: 20 kHz rates and 40 kHz peak deviations with 750 μ s de-emphasis filter.
- 7 With 750 μ s de-emphasis and pre-display "off", distortion is not specified for modulation outputs >4V peak. This condition can occur near maximum deviation for a measurement range, at rates <2 kHz.
- 8 After 30-day warm-up.
- 9 The 8902A fundamental RF Power measurement units are watts. Further internal processing is done on this number to display all other units.
- 10 When using 8484A sensor, the noise specification may mask the linearity specification and become the predominant error. When operating on the top RF power range, add the Power Sensor Linearity percentages found in the power sensor specifications.
- 11 The 8902A fundamental Tuned RF Level measurement units are volts. Further internal processing is done on this number to display all other units.

Special Functions (Cont'd)

Examples (cont'd)

This display is interpreted as follows:

Special Function		User-Requested Setting
Code	Name	
1.0	RF Input Attenuation and Gain	Automatic Selection
2.1	Audio Range	40% AM; 4 kHz FM; 4 radians ϕ M
3.0	RF and IF Filters	Automatic Selection (RF High-Pass Filter Out)
4.2	Tuned RF Level Detector Selection and Display Averaging	if Synchronous Detector with 1 Second Averaging Time
5.0	Audio Detector Response	Fast Response
6.1	Automatic Level Control	Fast Response
7.2	RF Frequency Resolution	100 Hz
8.8	Error Message Disable	All Errors Enabled
9.2	IF Gain	10 dB IF Gain
10.0	RF Power Range	Automatic Selection

Special Special Display. When SPCL is pressed again, the following display might result: (The user-selected Special Functions shown in the previous example are repeated in the Special Special Display. The Special Functions that were left in the automatic selection mode will display the suffix that was automatically selected.)

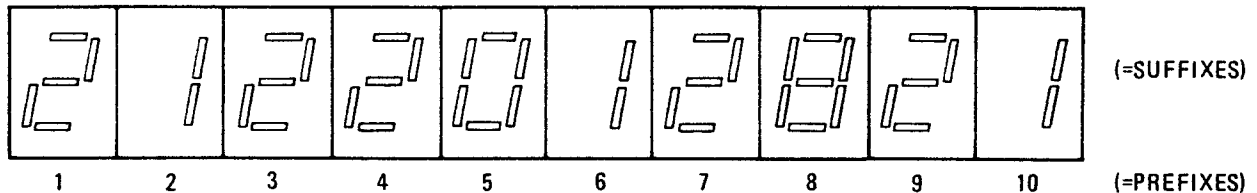

Table 1-1. Specifications (9 of 9)

FOOTNOTES (Cont'd)

- 12 Tuned RF Level accuracy will be affected by residual FM of the source-under-test. If the residual FM_{peak} is >50 Hz measured over a 30 second period in a 3 kHz BW, Tuned RF Level measurements should be made using the IF Average detector (30 kHz BW) by using Special Function 4.4. The Tuned RF Level measurement sensitivity, when using the IF Average detector, is -100 dBm.
- 13 IF Ranges 6 and 7 (see Tuned RF Level range plots) are only used in automatic operation for Tuned RF Level measurements below approximately -110 dBm for the IF Synchronous detector, and below approximately -85 dBm for the IF Average detector.
- 14 With the low-pass and high-pass audio filters used to stabilize frequency readings.
- 15 For demodulated signals, the residual noise generated by the 8902A must be accounted for in distortion measurements (that is, residual AM, FM, or ϕ M).
- 16 The >20 kHz low-pass filter is intended for minimum overshoot with squarewave modulation.

Special Functions (Cont'd)

Procedures

Entering Special Functions. To use a Special Function, key in the corresponding code, then press the SPCL key.

Special Display. To display the user-requested modes of Special Functions prefixed 1 through 10, press the SPCL key alone one time. The digit position (noted beneath the display) corresponds to the Special Function prefix, and the number displayed in that position corresponds to the Special Function suffix.

Special Special Display. To determine the actual instrument settings of Special Functions prefixed 1 through 10, press the SPCL key alone once while the Special Display is still active. (If the Special Display described above is not in effect, press the SPCL key twice to get this display.) The digit position corresponds to the Special Function prefix, and the number displayed in that digit corresponds to the Special Function suffix.

Examples

Entering Special Functions. To display the frequency of the signal in the IF (Special Function 34):

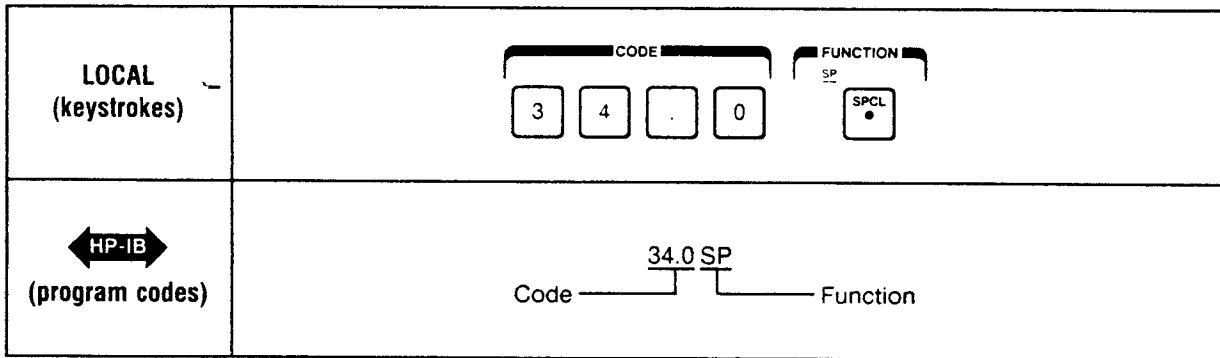

Viewing the Special Display. When SPCL is pressed alone once, the following display might result:

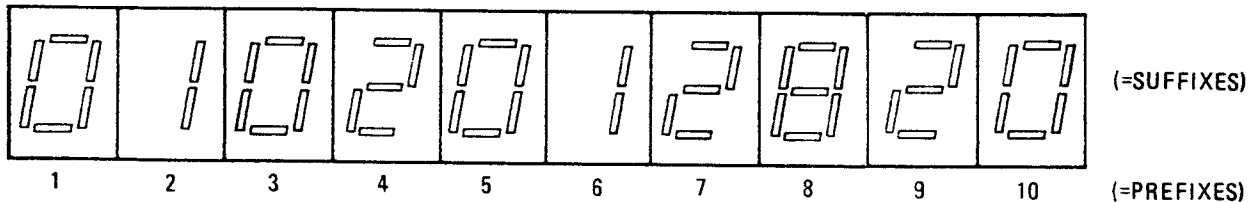

Table 1-2. Supplemental Information (1 of 6)

AMPLITUDE MODULATION

Detectors: + peak, - peak, \pm peak/2, peak hold, average (rms sinewave calibrated), rms.

Maximum Depth, Resolution, and Maximum Demodulated Output Sensitivity Across an Open Circuit (600 ohms Output Impedance)¹:

Maximum Resolution	Maximum Demodulated Output Sensitivity	Depths
0.1%	0.01 V/percent	$AM_{peak} \geq 40.0\%$
0.01%	0.1 V/percent	$AM_{peak} < 40.0\%$
0.001% (rms detector only)	0.1 V/percent	$AM_{rms} < 3.0\%$

FREQUENCY MODULATION

Maximum FM Deviation, Resolution, and Maximum Demodulated Output Sensitivity Across an Open Circuit (600 ohms Output Impedance)¹:

Maximum Resolution	Maximum Demodulated Output Sensitivity	Deviations (ΔF)
100 Hz	0.01 mV/Hz	$\Delta F_{peak} \geq 40 \text{ kHz}$
10 Hz	0.1 mV/Hz	$4.0 \text{ kHz} \leq \Delta F_{peak} < 40 \text{ kHz}$
1 Hz	1.0 mV/Hz	$\Delta F_{peak} < 4 \text{ kHz}$
0.1 Hz (rms detector only)	1.0 mV/Hz	$\Delta F_{rms} < 0.3 \text{ kHz}$

Resolution is increased one digit with 750 μ s de-emphasis and pre-display on. The demodulated output signal present at the MODULATION OUTPUT/AUDIO INPUT connector is increased in amplitude by a factor of 10 with 750 μ s de-emphasis.

Special Functions (Cont'd)
Special Function Summary (9 of 9)

Special Function Name	Program Code Code	Description	Default Parameter	Disabled By								Comments	Related Detailed Operating Instructions
				Lights SPLC Key	Display Timed	Volatile Memory Storage	Non-Volatile Memory Storage	AUTO OP. Key	Any Meas. Key	Clear Key	All Keys		
Display Tuned RF Level Calibration Factors	38.1	Display calibration factor for Range #1	0.0%	Y	Y	Y	Y	Y	Y	Y	Y	Y	Tuned RF Level Calibration and Calibration Factors
	38.2	Display calibration factor for Range #2	0.0%	Y	Y	Y	Y	Y	Y	Y	Y	Y	
	38.3	Display calibration factor for Range #3	0.0%	Y	Y	Y	Y	Y	Y	Y	Y	Y	
Enter Tuned RF Level Calibration Factors	39.1	Enter calibration factor for Range #1.	Calc.* Value	N	Y	Y	Y	Y	Y	Y	Y	Y	Tuned RF Level Calibration and Calibration Factors
	39.2	Enter calibration factor for Range #2.	Calc.* Value	N	Y	Y	Y	Y	Y	Y	Y	Y	
	39.3	Enter calibration factor for Range #3	Calc.* Value	N	Y	Y	Y	Y	Y	Y	Y	Y	
	39.9	Clear all calibration factors	--	N	Y	Y	Y	Y	Y	Y	Y	Y	

N = No; -- = Not applicable; Y = Yes; *Except the LOCAL, S (Shift), Blue Key, and Numeric Keys

Table 1-2. Supplemental Information (2 of 6)

FREQUENCY MODULATION (Cont'd)
Demodulated Output Distortion:

THD	Frequency Range	Rates	Deviations
<0.3%	150 kHz-400 kHz	20 Hz-10 kHz	<10 kHz

Detectors: +peak, -peak, \pm peak/2, peak hold, average (rms sinewave calibrated), rms.

Stereo Separation (50 Hz to 15 kHz): >47 dB.

PHASE MODULATION

Modulation Rates: usable from 20 Hz to 100 kHz with degraded performance.

Detectors: +peak, -peak, \pm peak/2, peak hold, average (rms sinewave calibrated), rms.

MODULATION REFERENCE

Carrier Frequency: 10.1 MHz

Modulation Rate: 10 kHz

Output Level: -25 dBm

FREQUENCY COUNTER

Modes: Frequency and Frequency Error (displays the difference between the frequency entered via the keyboard and the actual RF input frequency).

Sensitivity in Manual Tuning Mode: Approximate frequency must be entered from keyboard. 0.22 mV_{rms} (-60 dBm).

Using the RF amplifier and the IF amplifiers, sensitivity can be increased to approximately -100 dBm.

Special Functions (Cont'd)
Special Function Summary (8 of 9)

Special Function Name	Code	Program Code	Description	Disabled By										Comments	Related Detailed Operating Instructions	
				Default Parameter	Lights SPL Key	Display Timed	Volatile Memory Storage	Non-Volatile Memory Storage	AUTO Op. Key	Any Meas. Key	Clear Key	All Keys				
SINAD Measurement	29.0	29.0SP	Make an audio SINAD measurement	-	Y	N	N	N	N	N	Y	N	N	N	SINAD	
External Audio RMS Level Measurement	30.0	30.0SP	Measure the rms level of an external audio input at MODULATION OUTPUT/AUDIO INPUT	-	Y	N	N	N	N	N	Y	N	N	N	Measurements can only be made on inputs to MODULATION OUTPUT/AUDIO INPUT.	Audio Distortion and Level
LO Frequency	33.0	33.0SP	Measure the LO frequency	-	Y	N	N	N	N	N	Y	N	N	N	LO Frequency	
IF Frequency	34.0	34.0SP	Measure the IF frequency	-	Y	N	N	N	N	N	Y	N	N	N	IF Frequency	
RF Level	35.0	35.0SP	Measure the RF level of the RF input signal at INPUT using the RF peak detector.	-	Y	N	N	N	N	N	Y	N	N	N	RF Level	
Peak Tuned RF Level	36.0	36.0SP	Measure the peak tuned RF level falling within the tuned IF range	-	Y	N	N	N	N	N	Y	N	N	N	Peak Tuned RF Level	
RF Power ¹ Calibration Factors	37.0	37.0SP	Use automatic calibration factors	Y	N	-	N	N	N	N	Y	N	N	N	RF Power Calibration Factors	
	37.1	37.1SP	Use manual calibration factors	-	N	-	N	N	N	N	Y	N	N	N		
	37.2	37.2SP	Display calibration factor status; 0-automatic 1-manual	0	Y	Y	N	N	N	N	Y	N	N	N	RF CAL FACTOR shows the value currently being used. The appropriate keys must be pressed for listed action to occur; refer to RF Power.	
	37.3	37.3SP	Enter automatic calibration factor	-	N	-	N	N	N	N	Y	N	N	N		
	37.4	37.4SP	Display table size	-	Y	Y	Y	Y	Y	Y	Y	Y	Y	Y		
	37.5*	37.5SP	Recall reference calibration factor	-	Y	Y	Y	Y	Y	Y	Y	Y	Y	Y		
	37.6*	37.6SP	Recall next frequency/calibration factor	-	Y	Y	Y	Y	Y	Y	Y	Y	Y	Y		
	37.9	37.9SP	Clear table	-	N	-	N	N	N	N	Y	N	N	N		

N - No; - Not applicable; Y - Yes; *Except the LOCAL, S (Shift), Blue Key, and Numeric Keys

Table 1-2. Supplemental Information (3 of 6)

INTERNAL TIME BASE REFERENCE

Internal Reference Accuracy: Overall accuracy is a function of time-base calibration \pm aging rate \pm temperature effects \pm line voltage effects \pm short-term stability.

	Standard	Option 002
Aging Rate	$<1 \times 10^{-6}/\text{mo.}$	$<1 \times 10^{-9}/\text{day}$
Temperature Effects	$<2 \times 10^{-7}/^{\circ}\text{C}$	$<2 \times 10^{-10}/^{\circ}\text{C}$
Line Voltage Effects (+5%, -10% Line Voltage Change)	$<1 \times 10^{-6}$	$<6 \times 10^{-10}$
Short Term Stability	---	$<1 \times 10^{-9}$ for 1s average

RF POWER

Zero Drift of Meter:

$\pm 0.03\%$ of full scale/ $^{\circ}\text{C}$ on lowest range.

Decrease by a factor of 10 for each higher range.

Noise (at Constant Temperature, Peak Change Over Any One-Minute Interval For the 11722A Sensor Module and 8481A/1B/1H/2A/2B/2H/3A/5A Sensors):

0.4% of full scale on range 1 (lowest range).

0.13% of full scale on range 2.

0.013% of full scale on range 3.

0.0013% of full scale on range 4.

0.00013% of full scale on range 5.

For HP 8484A Sensor multiply noise by five on all ranges.

Zero Drift of Sensors (1 hour, at constant temperature after 24-hour warm-up):

$\pm 0.1\%$ of full scale on lowest range for 11722A Sensor Module and 8481A/1B/1H/2A/2B/2H/3A/5A sensors.

$\pm 2.0\%$ of full scale on lowest range for 8484A sensor. Decrease by a factor of 10 for each higher range.

RF Power Ranges of 8902A Measuring Receiver with 11722A Sensor Module:

-20 dBm to -10 dBm (10 μW to 100 μW), Range 1.

-10 dBm to +0 dBm (100 μW to 1 mW), Range 2.

+0 dBm to +10 dBm (1 mW to 10 mW), Range 3.

+10 dBm to +20 dBm (10 mW to 100 mW), Range 4.

+20 dBm to +30 dBm (100 mW to 1W), Range 5.

Special Functions (Cont'd)
Special Function Summary (7 of 9)

Special Function Name	Code	Program Code ↕ HP-IB	Description	Disabled By							Comments	Related Detailed Operating Instructions	
				Default Parameter	Lights SPCL Key	Display Timed	Volatile Memory Storage	Non-Volatile Memory Storage	AUTO OP Key	Any Meas. Key			Clear Key
HP-IB Address	21.0	21.0SP	Displays HP-IB address in form AAAAAA.TLS. AAAAAA - binary address. T - 1 talk only. L - 1 listen only. S - 1 requesting service.										HP-IB Address
Service Request	22.NN	22.NNSP	Enables a condition to cause a service request. NN is the sum of any combination of the weighted conditions below: 1 Data ready 2 HP-IB error (cannot be disabled) 4 Instrument error 8 Limit exceeded 16 Desire external controller attention 32 Recalibrate 64 Readback SRQ mask	22.2									Service Request Condition
External Attenuation	25.2	25.2SP	Display value of external attenuation in dB	0 dBm									External Attenuation
Set Reference	26.0	26.0SP	Exit attenuator measurement	0 dBm									Attenuator Measurements
	26.1	26.1SP	Re-enter attenuator measurement	0 dBm									
Frequency Offset Control	27.0	27.0SP	Exit Frequency Offset Mode										Frequency Offset Control
	27.1	27.1SP	Re-enter Frequency Offset Mode										
	27.2	27.2SP	Display external LO frequency	0 MHz									
	27.3	27.3SP	Enter and enable external LO frequency										

N - No; Not applicable; Y - Yes; *Except the LOCAL, S (Shift), Blue Key, and Numeric Keys

Table 1-2. Supplemental Information (4 of 6)

RF POWER (Cont'd)

Response Time (0 to 99% of Reading):

- <10 seconds, Range 1.
- <1 second, Range 2.
- <100 milliseconds, Range 3-5.

Displayed Units:

watts, dBm, dB_{relative}, %_{relative}, volts, mV, μ V, dB V, dB mV, dB μ V.

Internal Non-Volatile Cal Factor Tables (User Modifiable using Special Functions):

Maximum number of Cal Factor/Frequency entries:

- Table #1 (Primary): 16 pairs plus Reference Cal Factor;
- Table #2 (Frequency Offset): 22 pairs plus Reference Cal Factor.

Maximum Allowed Frequency Entry: 42 GHz.

Frequency Entry Resolution: 50 kHz.

Cal Factor Range: 40 to 120%.

Cal Factor Resolution: 0.1%.

POWER REFERENCE

Frequency: 50 MHz nominal.

SWR: 1.05 nominal.

Front-Panel Connector: Type-N female.

TUNED RF LEVEL

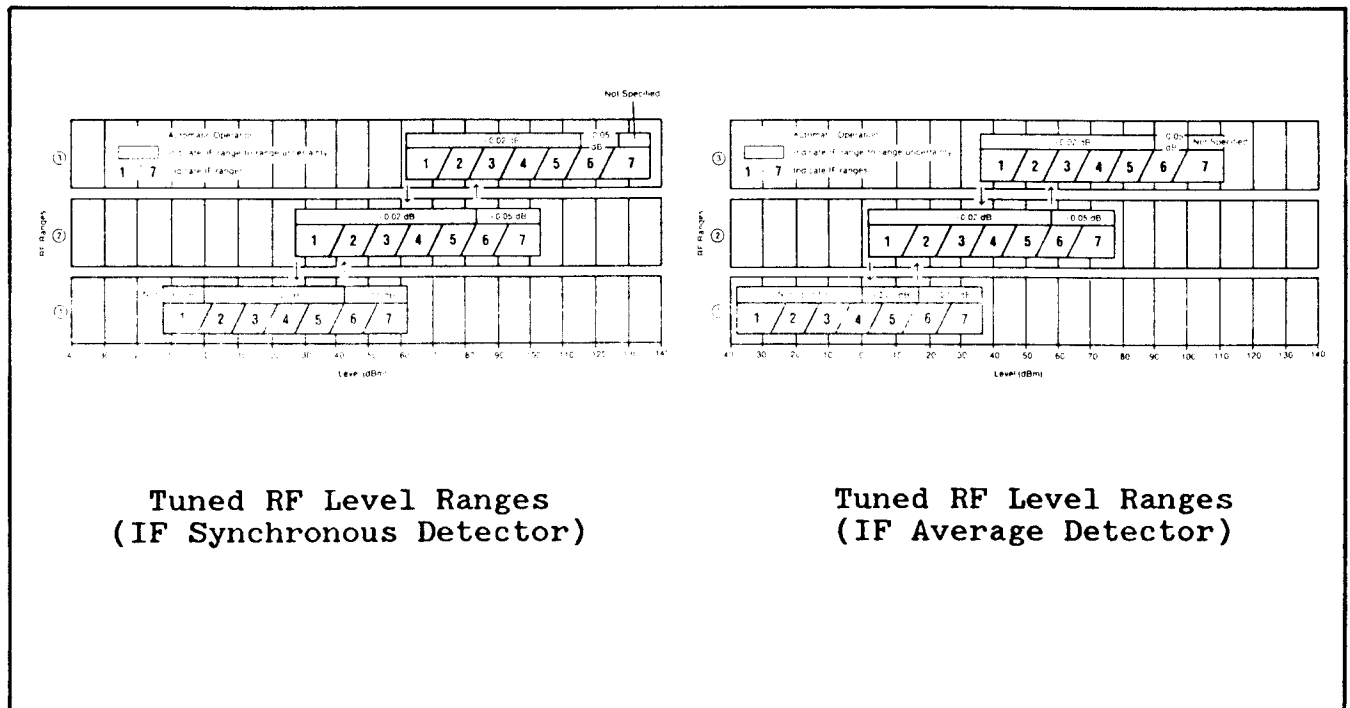

Special Function 1.9 reduces Tuned RF Level minimum sensitivity by 10 dB and shifts RF Range 3 up by 10 dB.

Special Functions (Cont'd)
Special Function Summary (6 of 9)

Special Function Name	Code	Program Code ↕ RPTD	Description	Disabled By										Comments	Related Detailed Operating Instructions	
				Default Parameter	Tlghts SPL Key	Display Timed	Volatile Memory Storage	Non-Volatile Memory Storage	AUTO OP. Key	Any Meas. Key	Clear Key	All Keys				
Time Base Check	15.0	15.0SP	Display Error 12 if Option 002 installed and oven cold.	-	Y	Y	N	Y	Y	Y	Y	Y	Y	Y		
	15.1	15.1SP	Display 0 if Option 002 installed and oven warm, or if Option 002 not installed. Displayed 0 if internal time base is being used. Display 1 if external time base is being used.	-	Y	Y	N	Y	Y	Y	Y	Y	Y	Y	Y	
AM Calibration Factor	16.0	16.0SP	Disable AM calibration factor	-	N	Y	N	Y	Y	Y	Y	Y	Y	Y		AM Calibration
	16.1	16.1SP	Enable AM calibration factor	100%	N	-	N	Y	Y	Y	Y	Y	Y	Y		Blue Key, % of AL FAC:TOR displays status. If disabled, 100% (note 1% resolution). If enabled, calibration factor value displayed (resolution of 0.01%).
	16.2	16.2SP	Display AM calibration factor (0 if not enabled)	100%	Y	Y	Y	Y	Y	Y	Y	Y	Y	Y		
FM Calibration Factor	17.0	17.0SP	Disable FM calibration factor	-	N	Y	N	Y	Y	Y	Y	Y	Y	Y		FM Calibration
	17.1	17.1SP	Enable FM calibration factor	100%	N	-	N	Y	Y	Y	Y	Y	Y	Y		Blue Key, % of AL FAC:TOR displays status. If disabled, 100% (note 1% resolution). If enabled, calibration factor value displayed (resolution of 0.01%).
	17.2	17.2SP	Display FM calibration factor (0 if not enabled)	100%	Y	Y	Y	Y	Y	Y	Y	Y	Y	Y		
Tone-Burst Receiver	18.NN	18.NNSP	Configures instrument as a tone-burst receiver. A time delay of NN ms is inserted between detection of a carrier and unsqueching of the output at MODULATION OUTPUT/AUDIO INPUT. Range of NN is 1 to 99 ms. If NN is 0, delay is 99 ms.	99 ms	Y	N	N	N	N	N	N	N	N	N		Tone Burst Receiver

N No. Not applicable, Y Yes; *Except the LOCAL, S (Shift), Blue Key, and Numeric Key.

Table 1-2. Supplemental Information (5 of 6)

TUNED RF LEVEL (Cont'd)

Absolute Level Measurement Accuracy at Low Levels (at Constant Temperature and After RF Range Calibration is Completed)²:

Absolute Level Measurement Accuracy is a function of the RF Power and Tuned RF Level measurement accuracy. Product Note 8902A-1 explains how both of these measurements affect absolute level measurement accuracy. For a source with an output SWR of 1.7 and level of -110 dBm the typical absolute level measurement accuracy is 0.46 dB rss and 1.02 dB worst case.

IF Frequency: 455 kHz.

Acquisition Time:

<4 seconds, \geq -110 dBm.

<10 seconds, \geq -127 dBm.

Response Time (Responding to Changes in Level of an Acquired Signal):

<2 seconds, \geq -110 dBm.

<5 seconds, \geq -127 dBm.

Displayed Units:

watts, dBm, dB_{relative}, %_{relative}, volts, mV, μ V, dB V, dB mV, dB μ V.

AUDIO FREQUENCY COUNTER

Displayed Resolution: 6 digits

Measurement Rate: 2 readings/s.

Counting Technique: Reciprocal with internal 10 MHz time base.

Audio Input Impedance: 100 kohms nominal.

AUDIO DISTORTION

Measurement 3 dB Bandwidth: 20 Hz to 50 kHz.

Detection: True rms.

Measurement Rate: 1 reading/s.

Audio Input Impedance: 100 kohms nominal.

AUDIO RMS LEVEL

Full Range Display: 0.3000V, 4.000V.

AC Converter: True-rms responding for signals with crest factor \leq 3.

Measurement Rate: 2 readings/s.

Audio Input Impedance: 100 kohms nominal.

AUDIO FILTERS

De-Emphasis Filter Time Constant Accuracy: \pm 3%.

High-Pass and Low-Pass Filter 3 dB Frequency Accuracy: \pm 3%.

>20 kHz Low-Pass Filter: 3 dB Cutoff Frequency: 100 kHz nominal.

Overshoot on Squarewave Modulation³: <1%.

Special Functions (Cont'd)

Special Function Summary (5 of 9)

Special Function		Program Code Code HP-IB	Description	Disabled By										Comments	Related Detailed Operating Instructions		
Name	Code			Default Parameter	Lights SPL Key	Display Timed	Volatile Memory	Non-Volatile Memory Storage	AUTO OP. Key	Any Meas. Key	Clear Key	All Keys					
AM Calibration	13.0	13.0SP	Display computed peak AM depth	-	-	-	-	-	-	-	-	-	-	-	-	Lights CALIBRATE	AM Calibration
	13.1	13.1SP	Display demodulated peak residual AM depth	-	-	-	-	-	-	-	-	-	-	-	-	Lights CALIBRATE Fixes 2.2 SPCL	
	13.2	13.2SP	Display demodulated peak AM depth	-	-	-	-	-	-	-	-	-	-	-	-	Lights CALIBRATE Fixes 2.2 SPCL	
Limit	14.0	14.0SP	Clear limits; turn off LIMIT annunciator	-	-	-	-	-	-	-	-	-	-	-	-	-	Limit
	14.1	14.1SP	Set lower limit to RATIO reference	0.15 kHz	-	-	-	-	-	-	-	-	-	-	-	-	
	14.2	14.2SP	Set upper limit to RATIO reference	1300 MHz	-	-	-	-	-	-	-	-	-	-	-	-	
	14.3	14.3SP	Restore lower limit	-	-	-	-	-	-	-	-	-	-	-	-	-	
	14.4	14.4SP	Restore upper limit	-	-	-	-	-	-	-	-	-	-	-	-	-	
	14.5	14.5SP	Display lower limit	0.15 kHz	-	-	-	-	-	-	-	-	-	-	-	-	
	14.6	14.6SP	Display upper limit	1300 MHz	-	-	-	-	-	-	-	-	-	-	-	-	
	14.7	14.7SP	Display measurement code in which lower limit was selected	0.005	-	-	-	-	-	-	-	-	-	-	-	-	
	14.8	14.8SP	Display measurement code in which upper limit was selected	0.005	-	-	-	-	-	-	-	-	-	-	-	-	
	14.9	14.9SP	Display limit status in the format Lower. Upper where 0=disabled and 1=enabled.	0.0	-	-	-	-	-	-	-	-	-	-	-	-	

N = No; - = Not applicable; Y = Yes; *Except the LOCAL, S (Shift), Blue Key, and Numeric Keys

Table 1-2. Supplemental Information (6 of 6)

RF INPUT

Tuning:

Normal Mode: Automatic and Manual frequency entry.

Track Mode: Automatic and Manual frequency entry, $f_c \geq 10$ MHz.

Acquisition Time (Automatic Operation): ~ 1.5 s.

Input Impedance: 50 ohms nominal.

Maximum Safe DC Input Level: 5V.

8902A REAR-PANEL INPUTS/OUTPUTS

FM Output: 10 kohm impedance, -9V to 6V into an open circuit: approximately 6V/MHz, dc-coupled, 16 kHz bandwidth (one pole).

AM Output: 10 kohm impedance, -4V to 0V into an open circuit: approximately 8 mV/%, dc coupled, 16 kHz bandwidth (one pole).

Recorder Output: DC voltage proportional to the measured results, 1 kohm impedance, 0V to 4V for each resolution range into an open circuit.

IF Output: 50 ohm impedance, 150 kHz to 2.5 MHz, -27 dBm to -3 dBm.

10 MHz Reference Output: 50 ohm impedance, TTL levels (0V to > 2.2 V into an open circuit), available only with Option 002, 1×10^{-9} /day internal reference, outputs internal reference only.

10 MHz Reference Input:⁴ > 500 ohm impedance, 0.5 V_{peak-to-peak} minimum input level.

LO Input (Option 003): 50 ohm impedance, approximately 1.27 MHz to 1301.5 MHz, 0 dBm.

RF Switch Remote Control Output: Provides output signals necessary to remotely control either an HP 33311B Option 011 or an HP 8761A RF Switch.

Frequency Offset Mode Remote Control Output: TTL high output if in frequency offset mode (Special Function 27.1 or 27.3) with an external LO frequency > 0 , TTL low output for all other cases.

FOOTNOTES

¹ For optimum flatness, cables should be terminated with their characteristic impedance.

² Tuned RF Level accuracy will be affected by residual FM of the source-under-test. If the residual FM_{peak} is > 50 Hz measured over a 30 second period in a 3 kHz BW, Tuned RF Level measurements should be made using the IF Average detector (30 kHz BW) by using Special Function 4.4. The Tuned RF Level measurement sensitivity, when using the IF Average detector, is -100 dBm.

³ The > 20 kHz low-pass filter is intended for minimum overshoot with squarewave modulation.

⁴ External reference accuracy affects accuracy of all measurements.

Special Functions (Cont'd)
Special Function Summary (4 of 9)

Special Function		Program Code Code \leftrightarrow HP1B	Description	Disabled By							Comments	Related Detailed Operating Instructions		
Name	Code			Default Parameter	Lights SPCL Key	Display Timed	Volatile Memory Storage	Non-Volatile Memory Storage	AUTO OP. Key	Any Meas. Key			Clear Key	All Keys
IF Gain	9.0	9.0SP	Automatic Selection	Y	-	-	-	-	-	-	-	-	IF Gain	
	9.1	9.1SP	0 dB IF gain	-	-	-	-	-	-	-	-	-		
	9.2	9.2SP	10 dB IF gain	Y	-	-	-	-	-	-	-	-		
	9.3	9.3SP	20 dB IF gain	-	-	-	-	-	-	-	-	-		
	9.4	9.4SP	30 dB IF gain	Y	-	-	-	-	-	-	-	-		
	9.5	9.5SP	40 dB IF gain	-	-	-	-	-	-	-	-	-		
	9.6	9.6SP	50 dB IF gain	-	-	-	-	-	-	-	-	-		
	9.7	9.7SP	60 dB IF gain	-	-	-	-	-	-	-	-	-		
RF Power Range	10.0	10.0SP	Automatic Selection	Y	-	-	-	-	-	-	-	-	RF Power	
	10.1	10.0SP	Range #1 (most sensitive range)	-	-	-	-	-	-	-	-	-		
	10.2	10.2SP	Range #2	-	-	-	-	-	-	-	-	-		
	10.3	10.3SP	Range #3	-	-	-	-	-	-	-	-	-		
	10.4	10.4SP	Range #4	-	-	-	-	-	-	-	-	-		
	10.5	10.5SP	Range #5 (least sensitive range)	-	-	-	-	-	-	-	-	-		
Previous Ratio	11.2	11.2SP	Display previous ratio reference	100%	Y	Y	Y	Y	Y	Y	Y	Y	Ratio and Log/Lin	
FM Calibration	12.0	12.0SP	Display computed peak FM deviation	-	-	-	-	-	-	-	-	-	Lights CALIBRATE Lights CALIBRATE Fixes 2.2 SPCL Lights CALIBRATE Fixes 2.2 SPCL	FM Calibration
	12.1	12.1SP	Display demodulated peak residual FM deviation	-	-	-	-	-	-	-	-	-		
	12.2	12.2SP	Display demodulated peak FM deviation	-	-	-	-	-	-	-	-	-		

Table 1-3. Recommended Test Equipment (1 of 4)

Instrument Type	Critical Specifications	Suggested Model	Use*
AM/FM Test Source	Carrier Frequency: within range 10 to 1300 MHz Output Level: >-20 dBm FM Deviation: 400 kHz peak maximum FM Distortion: <-72 dB at 12.5 MHz carrier with 12.5 kHz deviation and <10 kHz rate <-72 dB at 400 MHz carrier and 400 kHz deviation at <100 kHz rate FM Flatness: +0.1% from 20 Hz to 100 kHz rates; +0.25% to 200 kHz rates CW Residual FM: <3 Hz rms in a 50 Hz to 3 kHz bandwidth at 560 MHz Incidental AM: <0.08% AM at 100 MHz with <50 kHz peak deviation and 1 kHz rate in a 50 Hz to 3 kHz bandwidth AM Depth: 5% to 99% AM Distortion: <-66 dB at <50% AM at 20 Hz to 100 kHz rates; <-60 dB at <95% AM at 20 Hz to 100 kHz rates AM Flatness: +0.1% from 50 Hz to 50 kHz; +0.25% from 20 Hz to 100 kHz Incidental ϕ M: <0.008 rad peak at 12.5 MHz with 50% AM at a 1 kHz rate in a 50 Hz to 3 kHz bandwidth Residual AM: <0.01% rms in a 50 Hz to 3 kHz bandwidth AM Linearity: +0.1% at <95% AM; +0.2% at <99% AM	HP 11715A	P,A,T
Attenuator 6 dB	Frequency Range: 0.15 to 1300 MHz SWR Maximum: 1.2 Attenuation Accuracy: \pm 0.4 dB	HP 8491A opt. 006	P
Audio Analyzer	Fundamental Frequency Range: 20 Hz to 100 kHz Distortion Range: -70 dB minimum Distortion Accuracy: +2 dB Low-Pass Filters: 30 and 80 kHz Oscillator Level: 3V maximum into 600 ohm Oscillator Distortion: <-70 dB Oscillator Frequency Accuracy: +2%	HP 8903A	P,A,T
*C=Operator's Checks; P=Performance Tests; A=Adjustments; T=Troubleshooting			

Special Functions (Cont'd)
Special Function Summary (3 of 9)

Special Function		Program Code ↕	Description	Disabled By										Comments	Related Detailed Operating Instructions	
Name	Code			Default Parameter	Lights SPCL Key	Display Timed	Volatile Memory Storage	Non-Volatile Memory Storage	AUTO OP. Key	Any Meas. Key	Clear Key	All Keys				
Audio Detector Response: Audio Peak Det. Response and RMS Detector Digital Averaging Response	5.0	5.0SP	Fast	Y	-	-	-	-	-	-	-	-	-	-	-	Audio Detector Response
	5.1	5.1SP	Slow	-	N	N	-	-	-	-	-	-	-	-	-	-
AM ALC Response	6.0	6.0SP	Slow AM ALC (AM rates > 20 Hz)	Y	-	-	-	-	-	-	-	-	-	-	-	AM ALC Response Time
	6.1	6.1SP	Fast AM ALC (AM rates > 1 kHz)	-	N	N	-	-	-	-	-	-	-	-	-	-
	6.2	6.2SP	AM ALC off	-	N	N	-	-	-	-	-	-	-	-	-	-
RF Frequency Resolution	7.0	7.0SP	Automatic Selection	Y	-	-	-	-	-	-	-	-	-	-	-	RF Frequency Resolution
	7.1	7.1SP	10 Hz	-	N	N	-	-	-	-	-	-	-	-	-	-
	7.2	7.2SP	100 Hz	-	N	N	-	-	-	-	-	-	-	-	-	-
	7.3	7.3SP	1 kHz	-	N	N	-	-	-	-	-	-	-	-	-	-
Error Message Disable	8.0	8.0SP	Automatic Selection	Y	-	-	-	-	-	-	-	-	-	-	-	Disable Error Message Control
	8.1	8.1SP	Errors Disabled: 01	-	Y	Y	-	-	-	-	-	-	-	-	-	-
	8.2	8.2SP	02 03	-	Y	Y	-	-	-	-	-	-	-	-	-	-
	8.3	8.3SP	01 02 03	-	Y	Y	-	-	-	-	-	-	-	-	-	-
	8.4	8.4SP	04	-	Y	Y	-	-	-	-	-	-	-	-	-	-
	8.5	8.5SP	01 04	-	Y	Y	-	-	-	-	-	-	-	-	-	-
	8.6	8.6SP	02 03 04	-	Y	Y	-	-	-	-	-	-	-	-	-	-
	8.7	8.7SP	01 02 03 04	-	Y	Y	-	-	-	-	-	-	-	-	-	-
8.8	8.8SP	All Errors Enabled	-	Y	Y	-	-	-	-	-	-	-	-	-	-	

N = No; - = Not applicable; Y = Yes; *Except the LOCAL, S (Shift), Blue Key, and Numeric Keys

Table 1-3. Recommended Test Equipment (2 of 4)

Instrument Type	Critical Specifications	Suggested Model	*Use
Audio Synthesizer	Frequency Range: 20 Hz to 400 kHz Output Level: +16 dBm (50 ohms) maximum Frequency Accuracy: +0.1% Level Flatness: +0.015 dB from 90 Hz to 10 kHz; +0.3 dB from 50 Hz to 100 kHz; +0.07 dB from 20 Hz to 200 kHz Distortion: <-50 dB from 20 Hz to 200 kHz	HP 3325A	P,A,T
Bandpass Filters	Needed if using the HP 8640B Opt. 002 Signal Generator	HP 11697A,C	P
Computing Controller	HP-IB compatibility as defined by IEEE Std 488 and the identical ANSI Std MC1.1: SH1, AH1, T2, TE0, L2, LE0, SR0, PP0, DC0, DT0, and C1, 2, 3, 4, 5.	HP 9825A/ 98034A/98213A HP 9835A/ 98034A/98332A	C,P,T
Digital Multimeter	DC Range: 0 to 50V DC Accuracy: +0.01% at 1V AC Range: 0 to 100V AC Accuracy: +0.01% at 2V and 2 kHz Ohms Range: 0 to 1 M ohms Ohms Accuracy: +1%	HP 3455A	A,T
Frequency Standard	Accuracy: +0.1 ppm recommended	House Standard	A
Oscilloscope	Bandwidth: less than 3 dB down 0 to 100 MHz Sensitivity: 5 mV per division minimum Input Impedance: 10 M ohms and 50 ohms Triggering: External and Internal	HP 1740A	C,A,T
Power Meter/ Power Sensor	Frequency Range: 150 kHz to 1300 MHz Impedance: 50 ohms Instrumentation Accuracy: +1% SWR: <1.1	HP 435A/8482A or HP 436A/8482A	P
*C=Operator's Checks; P=Performance Tests; A=Adjustments; T=Troubleshooting			

Table 1-3. Recommended Test Equipment (3 of 4)

Instrument Type	Critical Specifications	Suggested Model	*Use
Power Meter or Power Reference	Power Range: 1 mV Frequency Range: 50 MHz SWR: 1.05 Accuracy: $\pm 0.5\%$ (NBS calibrated) Power Output: 1.00 mW. Factory set to $\pm 0.7\%$ (NBS calibrated) Accuracy: $\pm 1.2\%$ worst case ($\pm 0.9\%$ rss) for one year (0 degrees C to 50 degrees C)	HP 432A HP 478A opt. H75 HP 435A opt. K05	P,A
Power Splitter	Frequency Range: 150 kHz to 1300 MHz Impedance: 50 ohms SWR: <1.1 Tracking: <0.25 dB	HP 11667A	P,A,T
Power Supply	Output Range: 0 to 25 Vdc	HP 6215A	T
Range Calibrator	Calibration Functions: outputs corresponding to power displays of 10 and 100 uW; 1, 10, and 100 mW. Calibration Uncertainty: $\pm 0.25\%$ in all ranges	HP 11683A	P,A
RF Spectrum Analyzer	Frequency Range: 0 to 2 GHz Input Level: +10 dBm maximum Display Range: 60 dB	HP 8559A/182T	A,T
Sensor Module	Compatible with HP 8902A Input SWR: <1.3, at RF Input, RF Range 1, 2 <1.5, at RF Input, RF Range 3 <1.3, at RF Input, RF Range 3 with Measuring Receiver's Special Function 1.9	HP 11722A	P,A,T
Service Accessory Kit	No substitution recommended.	HP 08901-60089	T
*C=Operator's Checks; P=Performance Tests; A=Adjustments; T=Troubleshooting			

Special Functions (Cont'd)
Special Function Summary (1 of 9)

Special Function Name	Program Code Code	Description	Disabled By								Comments	Related Detailed Operating Instructions	
			Default Parameter	Lights SPL Key	Display Timed	Volatile Memory Storage	Non-Volatile Memory Storage	AUTO OP. Key	Any Meas. Key	Clear Key			All Keys
RF Input Attenuation and Gain	1.0	Automatic selection	Y	-	-	-	-	-	-	-	-	-	RF Input Attenuation and Gain
	1.1	0 dB input attenuation	-	Y	-	-	-	-	-	-	-	-	
	1.2	10 dB input attenuation	-	Y	-	-	-	-	-	-	-	-	
	1.3	20 dB input attenuation	-	Y	-	-	-	-	-	-	-	-	
	1.4	30 dB input attenuation	-	Y	-	-	-	-	-	-	-	-	
	1.5	40 dB input attenuation	-	Y	-	-	-	-	-	-	-	-	
	1.6	50 dB input attenuation	-	Y	-	-	-	-	-	-	-	-	
	1.7	24 dB input gain	-	Y	-	-	-	-	-	-	-	-	
	1.8	14 dB input gain	-	Y	-	-	-	-	-	-	-	-	
	1.9	Automatic selection: 10 dB attenuator always inserted.	-	Y	-	-	-	-	-	-	-	-	
Audio Range	2.0	Automatic Selection	Y	-	-	-	-	-	-	-	-	-	AM Audio Range FM φM (Phase Modulation)
	2.4 ¹	AM (%) ≤4	-	Y	-	-	-	-	-	-	-	-	
	2.4	FM (kHz) ≤0.4	-	Y	-	-	-	-	-	-	-	-	
	2.1	φM (rad) ≤0.4	-	Y	-	-	-	-	-	-	-	-	
	2.2	AM (%) ≤40	-	Y	-	-	-	-	-	-	-	-	
	2.2	FM (kHz) ≤0.4 ²	-	Y	-	-	-	-	-	-	-	-	
	2.3	φM (rad) ≤40 ²	-	Y	-	-	-	-	-	-	-	-	

N = No; - = Not applicable; Y = Yes; *Except the LOCAL, S (Shift), Blue Key, and Numeric Keys

Table 1-3. Recommended Test Equipment (4 of 4)

Instrument Type	Critical Specifications	Suggested Model	*Use
Signal Generator	Frequency Range: 0.5 to 1100 MHz Output Level: +19 dBm maximum to 500 MHz; +13 dBm maximum to 1100 MHz Output Level Accuracy: +1 dB Frequency Accuracy: +1% Frequency Resolution: 1 kHz Modulation Capability: AM and FM AM Depth: 0 to 95% AM Accuracy: +10% FM Range: 0 to 400 kHz peak deviation FM Accuracy: +10%	HP 8640B opt. 001/002	C,P,A T
Signature Analyzer	External Count Range: to 15 MHz Because the signatures documented are unique to a given signature analyzer, no substitution is recommended.	HP 5004A	T
SWR Bridge	Frequency Range: 150 kHz to 1300 MHz Impedance: 50 ohms Directivity: >40 dB Connectors: Type N	Wiltron 60N50	P
*C=Operator's Checks; P=Performance Tests; A=Adjustments; T=Troubleshooting			

Table 1-4. Recommended Test Accessories

Accessory Type*	Recommended Part
Adapter (Type N Male to BNC Female connectors)	HP 1250-0067
Capacitor, 620 pF	HP 0160-3536
IC Extender Clip, 16 Pin	HP 1400-0734
Resistor, 909Ω 1% 1/4W	HP 0757-0422
Resistor, 1210Ω 1% 1/4W	HP 0757-0274
Resistor, 2150Ω 1% 1/4W	HP 0698-0084
Resistor, 4640Ω 1% 1/4W	HP 0698-3155
Tee (Coaxial, BNC, one Male and two Female connectors)	HP 1250-0781
50Ω Load (Male, BNC, coaxial)	HP 1250-0207
*Accessories listed in this table are only those not already contained in the Service Accessory Kit, HP 08901-60089.	

Special Functions (Cont'd)

Description (cont'd)

instrument settings of these functions can be displayed by pressing the SPCL key a second time while the Special Display is still active. This display is called the Special Special Display. Both displays can be disabled by pressing any key except the Blue Key, LOCAL, or S (shift) keys. (While either display is active, pressing the SPCL key selects the other display.)

A summary of User Special Functions is provided in the nine-page table in this instruction. Also included in this instruction are procedures for using Special Functions and for obtaining the Special Display and the Special Special Display.

SECTION II INSTALLATION

2-1. INTRODUCTION

This section provides the information needed to install the Measuring Receiver. Included is information pertinent to initial inspection, power requirements, line voltage selection, power cables, interconnection, environment, instrument mounting, storage and shipment. In addition, this section also contains the procedure for setting the internal HP-IB talk and listen address switches.

2-2. INITIAL INSPECTION

WARNING

To avoid hazardous electrical shock, do not perform electrical tests when there are signs of shipping damage to any portion of the outer enclosure (covers, panels, meters).

Inspect the shipping container for damage. If the shipping container or cushioning material is damaged, it should be kept until the contents of the shipment have been checked for completeness and the instrument has been checked mechanically and electrically. The contents of the shipment should be as shown in Figure 1-1. Procedures for checking electrical performance are given in Section IV. If the contents are incomplete, if there is mechanical damage or defect, or if the instrument does not pass the electrical performance test, notify the nearest Hewlett-Packard office. If the shipping container is damaged, or the cushioning material shows signs of stress, notify the carrier as well as the Hewlett-Packard office. Keep the shipping materials for the carrier's inspection.

2-3. PREPARATION FOR USE

2-4. Power Requirements

WARNING

To avoid the possibility of hazardous electrical shock, do not operate this instrument at line voltages greater than 126.5 Vac with line frequencies greater than 66 Hz. Leakage currents at these line settings may exceed 3.5 mA.

Special Functions

Description

General Information. Special Functions enable extended use of the instrument beyond the control normally available from dedicated front-panel keys. The Special Functions are best used after a thorough understanding of the instrument is grasped. Technicians can gain arbitrary control of the instrument as an aid in troubleshooting.

Special Functions are accessed via keyboard entry of the appropriate numeric code terminated by the SPCL key. (Refer to "Procedures".) The codes comprise a prefix, decimal, and suffix. Special Functions are disabled in different ways, depending on the function. Refer to the following comprehensive table for actions which clear or disable any Special Function. Special Functions are grouped by their prefixes into three categories as follows:

Prefix 0

Prefix 0 is the Direct Control Special Function intended for use in servicing the Measuring Receiver (discussed in detail in Section VIII). All instrument error messages and safeguards are inactive. If the Direct Control Special Function is entered inadvertently, press AUTOMATIC OPERATION.

Prefixes 1 to 39

Prefixes 1 to 39 are the User Special Functions that are used during normal instrument operation when a special configuration, a special measurement, or special information is required. All error messages and most safeguards remain in effect unless the operator disables them. These Special Functions are described in the table in this instruction.

Prefixes 40 to 99

Prefixes 40 to 99 are the Service Special Functions used to assist in troubleshooting an instrument fault (discussed in detail in Section VIII). The functions available include special internal measurements, software control, and special service tests and configurations. Most instrument safeguards are relinquished. If a Service Special Function is entered inadvertently, press AUTOMATIC OPERATION.

Viewing Special Function States. In addition to completing the entry of Special Function codes, the SPCL key enables viewing of some Special Function settings. The operator-requested settings of Special Functions prefixed 1 through 10 can be viewed by pressing the SPCL key once (following no numeric entry). This display is called the Special Display. If some of these Special Functions are in automatic modes (generally the 0-suffix setting), the actual

Power Requirements (Cont'd)

The Measuring Receiver requires a power source of 100, 120, 220, or 240 Vac, +5% to -10%, 48 to 66 Hz single phase. Option 004 also operates from 48 to 440 Hz single phase (120 Vac, +5% to -10% only). Power consumption is 200 V·A maximum.

WARNING

This is a Safety Class I product (i.e., provided with a protective earth terminal). An uninteruptible safety earth ground must be provided from the main power source to the product input wiring terminals, power cord, or supplied power cord set. Whenever it is likely that the protection has been impaired, the product must be made inoperative and be secured against any unintended operation.

If this instrument is to be energized via an external autotransformer, make sure the autotransformer's common terminal is connected to the earthed pole of the power source.

2-5. Line Voltage and Fuse Selection



CAUTION

BEFORE PLUGGING THIS INSTRUMENT into the Mains (line) voltage, be sure the correct voltage and fuse have been selected.

Verify that the line voltage selection cord and the fuse are matched to the power source. Refer to Figure 2-1, Line Voltage and Fuse Selection.

Fuses may be ordered under HP part numbers 2110-0083, 2.5A (250V normal blow) for 115 Vac operation and 2110-0043, 1.5A (250V normal blow) for 230 Vac operation.

2-6. Power Cables

WARNING

BEFORE CONNECTING THIS INSTRUMENT, the protective earth terminals of this instrument must be connected to the protective conductor of the (Mains) power cord. The Mains plug shall only be inserted in a socket outlet provided with a protective earth contact. The protective action must not be negated by the use of an extension cord (power cable) without a protective conductor (grounding).

SINAD (Cont'd)
(Special Function 29.0)

HP-IB Program Codes

AUDIO INPUT = A1
MODULATION OUTPUT = A0
1 kHz DISTN = D5
400 Hz DISTN = D6
LIN results = LN
LOG results = LG
SPCL = SP

Indications

Display: As the numeric code is entered, it appears on the display. When the SPCL key is pressed, the SINAD value is displayed along with the % or dB annunciator. The 1 kHz or 400 Hz annunciator is also displayed.

Front Panel: The LED within the SPCL key lights. The LED next to RMS lights. All measurement keys are turned off.

If FILTER or DE-EMPHASIS keys have been selected, the LEDs within these keys remain on. They are turned off if AUDIO INPUT is selected.

When AUDIO INPUT is selected, the LED within the key lights and the LEDs under MODULATION OUTPUT are turned off. If AUDIO INPUT is not selected or is turned off, the appropriate LED under MODULATION OUTPUT lights.

Related Functions

Audio Distortion and Level
Audio Frequency
Special Functions

Power Cables (Cont'd)

This instrument is equipped with a three-wire power cable. When connected to an appropriate ac power receptacle, this cable grounds the instrument cabinet. The type of power cable plug shipped with each instrument depends on the country of destination. Refer to Table 2-1 for the part numbers of the power cables available.

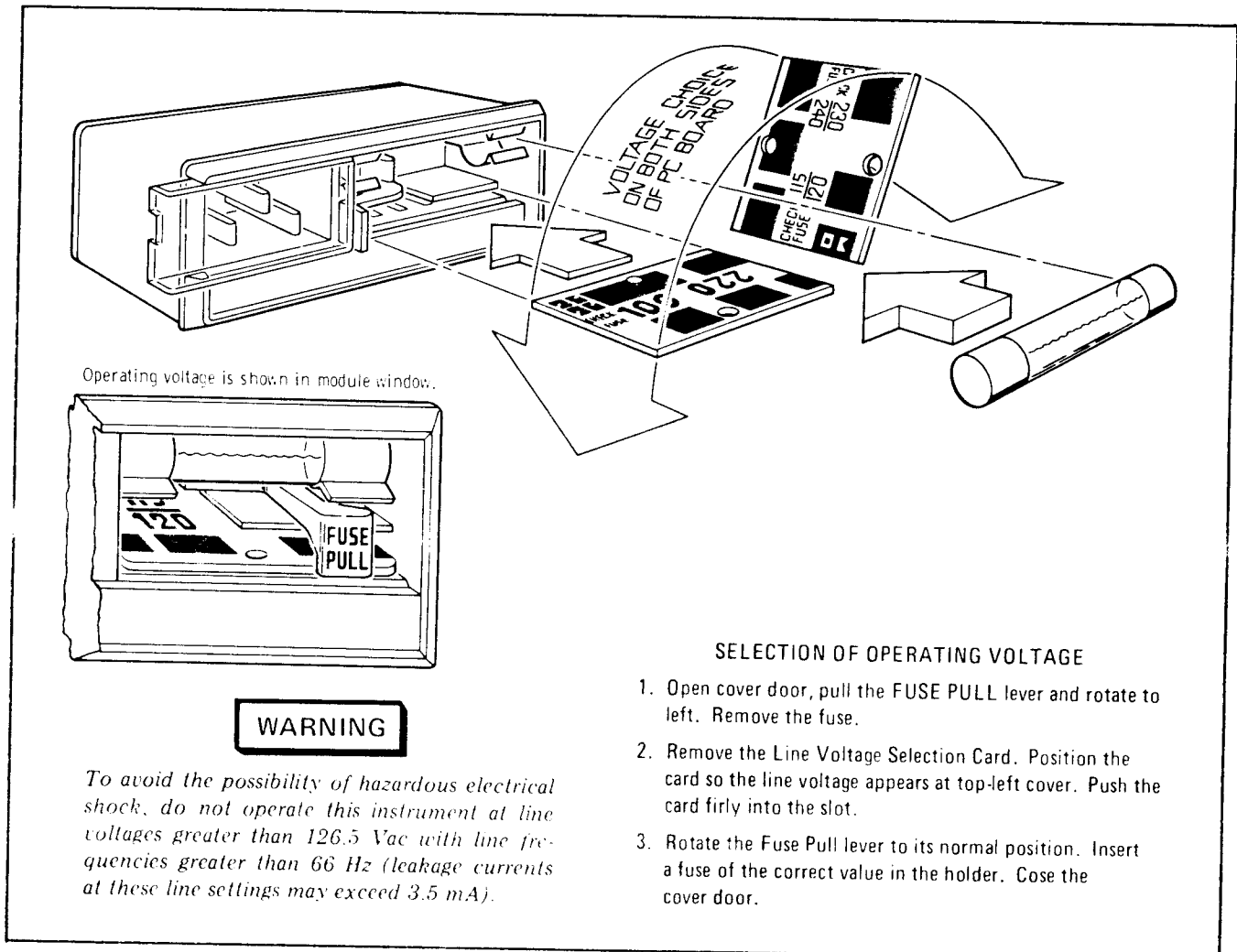

Figure 2-1. Line Voltage and Fuse Selection

2-7. HP-IB Address Selection

WARNING

This task should be performed only by service trained persons who are aware of the potential shock hazard of working on an instrument with protective covers removed.

To avoid hazardous electrical shock, the line (Mains) power cable should be disconnected before attempting to change the HP-IB address.

SINAD (Special Function 29.0)

Description

Special Function 29.0 enables the Measuring Receiver to make SINAD (Signal to Noise And Distortion) measurements that help determine the sensitivity of receivers. SINAD measurements are made identically to audio distortion measurements; but the result is calculated differently.

SINAD measurements can be made at frequencies of either 1 kHz or 400 Hz using the 1 kHz DISTN or 400 Hz DISTN keys (respectively).

SINAD can be measured on external audio signals using the AUDIO INPUT key when the input signal is applied to MODULATION OUTPUT/AUDIO INPUT. When the AUDIO INPUT key is not selected, the Measuring Receiver makes the measurement on the audio signal that is demodulated from the signal at the RF INPUT connector.

If AUDIO INPUT is not selected, the output available at MODULATION OUTPUT/AUDIO INPUT is not affected by this measurement.

Procedures

To make a SINAD measurement, first set the audio frequency under test to 400 Hz or 1 kHz.

Either external audio signals or internally demodulated signals can be measured.

To measure an external audio signal:

- Connect the signal to MODULATION OUTPUT/AUDIO INPUT.
- Press the AUDIO INPUT key on the front panel of the Measuring Receiver.

To measure an internally demodulated audio signal:

- Connect the frequency to be measured to RF INPUT.
- To change the bandwidth of the audio signal, press the appropriate filter keys. (Refer to Audio Filters.)

Select AM or FM as appropriate.



Key in 29.0 SPCL.

If the frequency-under-test is 400 Hz, press the Blue Key and 400 Hz DISTN (PEAK-) key. If the frequency-under-test is 1 kHz, no keys are pressed since the instrument defaults to this frequency.

Press the LOG/LIN key to display the result logarithmically.

If SINAD measurements are to be displayed relative to a reference, enter the value as a ratio reference using the RATIO key. (Refer to Ratio.)

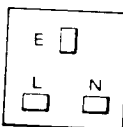
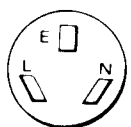
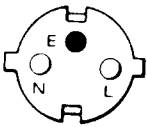
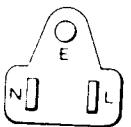
Table 2-1. AC Power Cables Available

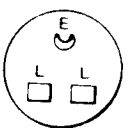
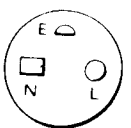
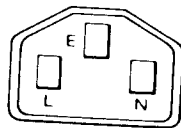
Plug Type	Cable HP Part Number	C D	Plug Description	Cable Length (inches)	Cable Color	For Use In Country
250V 	8120-1351 8120-1703	0 6	Straight*BS1363A 90°	90 90	Mint Gray Mint Gray	United Kingdom, Cyprus, Nigeria, Rhodesia, Singapore
250V 	8120-1369 8120-0696	0 4	Straight*NZSS198/ASC112 90°	79 87	Gray Gray	Australia, New Zealand
250V 	8120-1689 8120-1692	7 2	Straight*CEE7-Y11 90°	79 79	Mint Gray Mint Gray	East and West Europe, Saudi Arabia, Egypt So. Africa, India (unpolarized in many nations)
125V 	8120-1378 8120-1398 8120-1754 8120-1378 8120-1521 8120-1676	5 5 7 1 6 2	Straight*NEMA5-15P 90° Straight*NEMA5-15P Straight*NEMA5-15P 90° Straight*NEMA5-15P	80 80 36 80 80 36	Black Black Black Jade Gray Jade Gray Jade Gray	United States, Canada, Japan (100V or 200V), Mexico, Philippines, Taiwan
250V 	8120-2104	3	Straight*SEV1011 1959-24507 Type 12	79	Gray	Switzerland
250V 	8120-0698	6	Straight*NEMA6-15P			United States, Canada
220 V 	8120-1957 8120-2956	2 3	Straight*DHCK 107 90°	79 79	Gray Gray	Denmark
250 V 	8120-1860	6	Straight*CEE22-VI (Systems Cabinet use)			

*Part number shown for plug is industry identifier for plug only. Number shown for cable is HP Part Number for complete cable including plug.
E = Earth Ground; L = Line; N = Neutral

Service Request Conditon (Cont'd)
(Special Function 22)

Comments

HP-IB

For more information on the HP-IB operation, serial polling, and the Status Byte message, refer to the discussion, "HP-IB Operation" that appears earlier in Section III of this manual.

HP-IB

The HP-IB Address Special Function provides a convenient means to determine, at any time, whether a Require Service message is being issued by the Measuring Receiver.

Related Functions

HP-IB Address

HP-IB Operation (appears earlier in Section III)

Frequency Offset Control

Limit

RF Power

Tuned RF Level

HP-IB Address Selection (Cont'd) **HP-IB**

In the Measuring Receiver, the HP-IB talk and listen addresses are selectable by an internal switch (Figure 2-2). The following procedure explains setting of the switches. Refer to Table 2-2 for a listing of the talk and listen addresses. The address is factory set for a Talk address of "N" and a listen address of "." (period). (In binary, this is 01110; in decimal it is 14.) To change the HP-IB address, the top cover of the Measuring Receiver must be removed.

1. Disconnect the line (Mains) power cable.
2. Remove any HP-IB cables or connectors from the HP-IB connector.
3. Remove the Measuring Receiver's top cover.
 - a. Remove the two plastic feet from the rear of the top cover by removing the pan-head Pozidriv screw within each foot.
 - b. Unscrew the Pozidriv screw at the center of the rear edge of the top cover. This is a captive screw and will cause the top cover to pull away from the front frame.
 - c. Lift off the top cover.
4. Locate the HP-IB address switch on the A14 Remote Interface Assembly near the front right of the instrument. The A14 assembly may be recognized as having one brown and one yellow printed circuit board extractor.

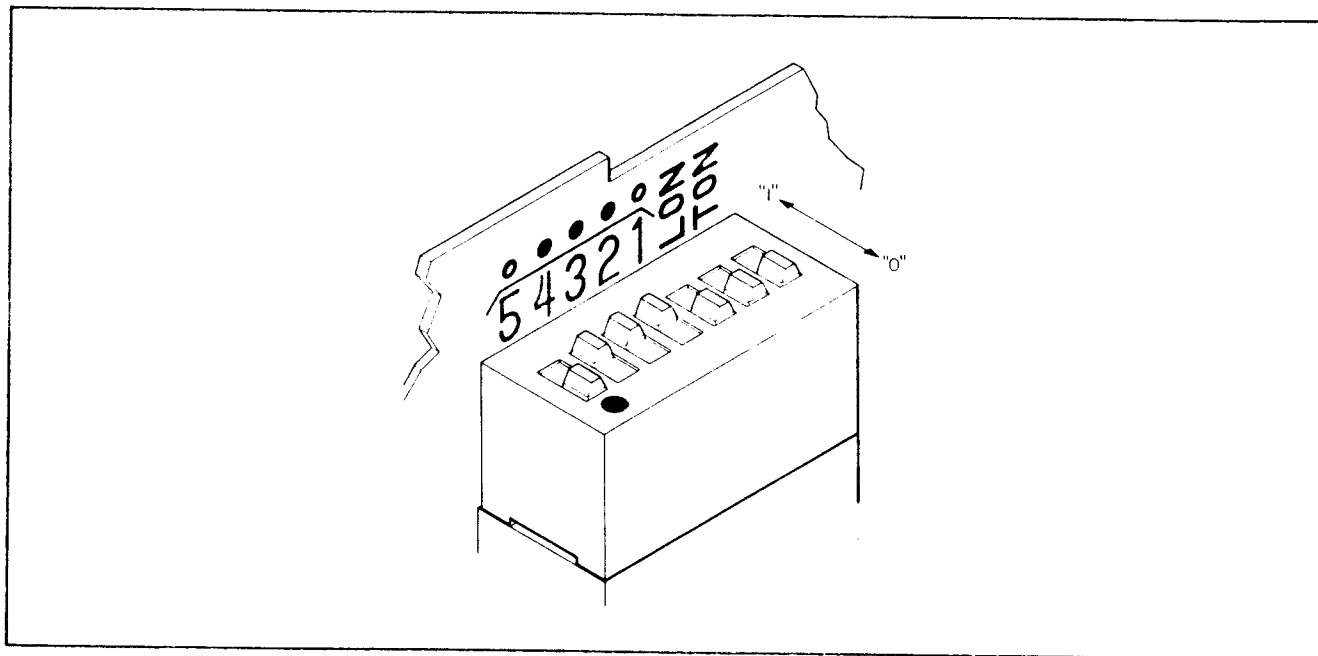

Figure 2-2. The HP-IB Address Switch Shown as Set by the Factory. The Address Shown is 01110 in Binary With Both Talk Only and Listen Only Off

Service Request Condition (Cont'd)
(Special Function 22)

Example

To set the Measuring Receiver to send a Require Service message for all conditions, first compute the Special Function suffix by summing all the weights.

$$(2+) 4 + 8 + 16 + 32 + 64 = 126$$

Key in 22.126 SPCL.

HP-IB Program Codes

Compute the Special Function code as described in "Procedure".

SPCL = SP

Indications

When any enabled condition occurs, both the RQS bit and the bit corresponding to the enabled condition are set in the status byte, and the SRQ control line on the HP-IB is set true. For reference, the Measuring Receiver's status byte is listed in the following table:

	MSB							LSB
Bit	8	7	6	5	4	3	2	1
Weight	128	64	32	16	8	4	2	1
Condition	0 (always)	SRQ Mask Set	Recalibrate	Frequency Offset Mode Change	Limit Exceeded	Instrument Error	HP-IB Code Error	Data Ready

Measuring Receiver's Status Byte

Display: As the numeric code is entered, it appears on the display. When the SPCL key is pressed, the display returns to show the measurement previously selected.

The SRQ LED next to the LOCAL key lights when a service request message is sent.

Front Panel: Special Function 22 has no effect on the SPCL key light.

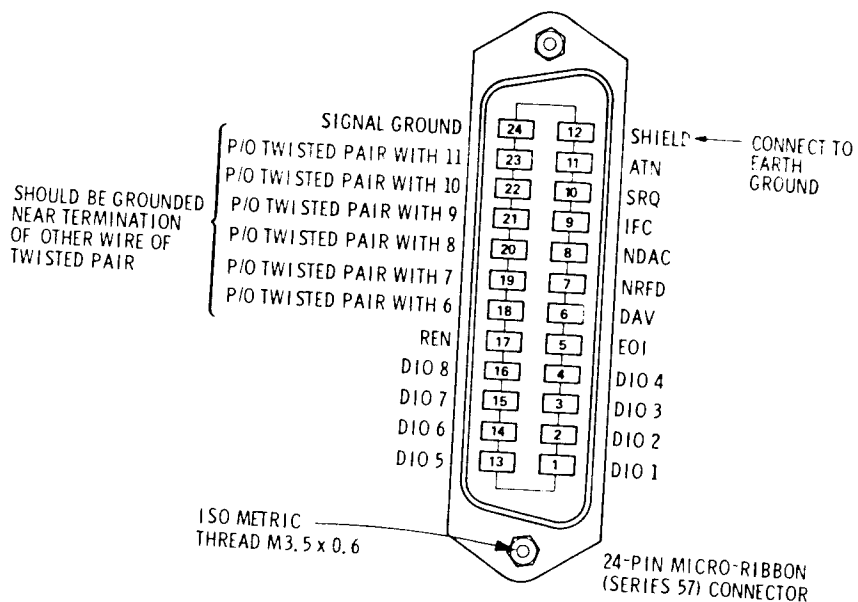

Logic Levels

The Hewlett-Packard Interface Bus Logic Levels are TTL compatible, i.e., the true (1) state is 0.0 Vdc to +0.4 Vdc and the false (0) state is +2.5 Vdc to +5.0 Vdc.

Programming and Output Data Format

Refer to Section III, Operation.

Mating Connector

HP 1251-0293; Amphenol 57-30240.

Mating Cables Available

HP 10833A, 1 metre (3.3 ft); HP 10833B, 2 metres (6.6 ft);
 HP 10833C, 4 metres (13.2 ft); HP 10833D, 0.5 metres (1.6 ft).

Cabling Restrictions

1. A Hewlett-Packard Interface Bus system may contain no more than 2 metres (6 ft) of connecting cable per instrument.
2. The maximum accumulative length of connecting cable for any Hewlett-Packard Interface Bus system is 20.0 metres (65.6 ft).

Figure 2-3. Hewlett-Packard Interface Bus Connection

Service Request Condition (Special Function 22)

Description

Various circumstances cause the Measuring Receiver to issue a Require Service message. (An HP-IB code error is one circumstance that causes a Require Service message.)

Using the keyboard and the SPCL key, the operator can enable one or more conditions to cause the Require Service message to be issued. The occurrence of an enabled condition sets both the bit corresponding to the condition and bit 7 (RQS bit) in the Status Byte.

The bits set in the status byte and the Require Service message are not cleared unless the status byte is read (by serial polling), a Clear message is received and executed by the Measuring Receiver, or a Controller Reset or Controller Clear Service Special Function is performed. The enabled Service Request conditions are always disabled again whenever a Clear message is received and executed by the Measuring Receiver or whenever a Controller Reset or Controller Clear Service Special Function is performed.

Procedure

To enable one or more conditions to cause the Measuring Receiver to issue a Require Service message, sum the weights of the conditions to be enabled (from the following table). This sum becomes the code suffix of Special Function 22. Enter the Special Function code (prefix, decimal, and suffix) via the numeric keyboard, then press the SPCL key. An HP-IB code error (weight = 2) will always cause a Require Service message. This condition cannot be disabled, and if the weight is not summed in, it will be assumed by the instrument.

Condition	Weight
Data Ready	1
HP-IB Code Error	2
Instrument Error	4
Limit Exceeded	8
Frequency Offset Mode Change	16
Recalibrate	32
SRQ Mask Set	64

HP-IB Address Selection (Cont'd) **HP-IB**

5. Use a pencil to set the switches to the desired HP-IB address and Talk Only (TON) or Listen Only (LON) condition. The switch is illustrated in Figure 2-2. Facing the board, the left hand switch (marked with a "5") is the most significant address bit (A5 in Table 2-2). Setting a switch toward the printed circuit board places it in its "1" position. If the TON and LON switches are both set to "1", the Talk Only setting will override. If the address switches and the TON switch are all set to "1", the Measuring Receiver will output one byte (the status byte) each measurement cycle. (Setting all switches to "1" defeats HP-IB operation.)
6. Reinstall the top cover by reversing the procedure in previous step 3.
7. Connect the line (Mains) power cable to the Line Power Module and reconnect the HP-IB cable to the HP-IB connector.
8. To confirm the setting, refer to "HP-IB Address" in the Detailed Operating Instructions in Section III of this manual.

HP-IB Table 2-2. Allowable HP-IB Address Codes

Address Switches					Talk Address Character	Listen Address Character	Decimal Equivalent	Address Switches					Talk Address Character	Listen Address Character	Decimal Equivalent
A5	A4	A3	A2	A1				A5	A4	A3	A2	A1			
0	0	0	0	0	@	SP	0	1	0	0	0	0	P	0	16
0	0	0	0	1	A	!	1	1	0	0	0	1	Q	1	17
0	0	0	1	0	B	"	2	1	0	0	1	0	R	2	18
0	0	0	1	1	C	#	3	1	0	0	1	1	S	3	19
0	0	1	0	0	D	\$	4	1	0	1	0	0	T	4	20
0	0	1	0	1	E	%	5	1	0	1	0	1	U	5	21
0	0	1	1	0	F	&	6	1	0	1	1	0	V	6	22
0	0	1	1	1	G	'	7	1	0	1	1	1	W	7	23
0	1	0	0	0	H	(8	1	1	0	0	0	X	8	24
0	1	0	0	1	I)	9	1	1	0	0	1	Y	9	25
0	1	0	1	0	J	*	10	1	1	0	1	0	Z	:	26
0	1	0	1	1	K	+	11	1	1	0	1	1	[;	27
0	1	1	0	0	L	,	12	1	1	1	0	0	\	<	28
0	1	1	0	1	M	-	13	1	1	1	0	1]	=	29
0	1	1	1	0	N	.	14	1	1	1	1	0	^	>	30
0	1	1	1	1	O	/	15	1	1	1	1	1	Invalid	Invalid	31

2-8. Interconnections

Interconnection data for the Hewlett-Packard Interface Bus is provided in Figure 2-3.

RF Frequency Error (Cont'd)

Example

To measure the error of an oscillator designed to operate at 30 MHz, connect the oscillator's output to the Measuring Receiver's RF INPUT connector:

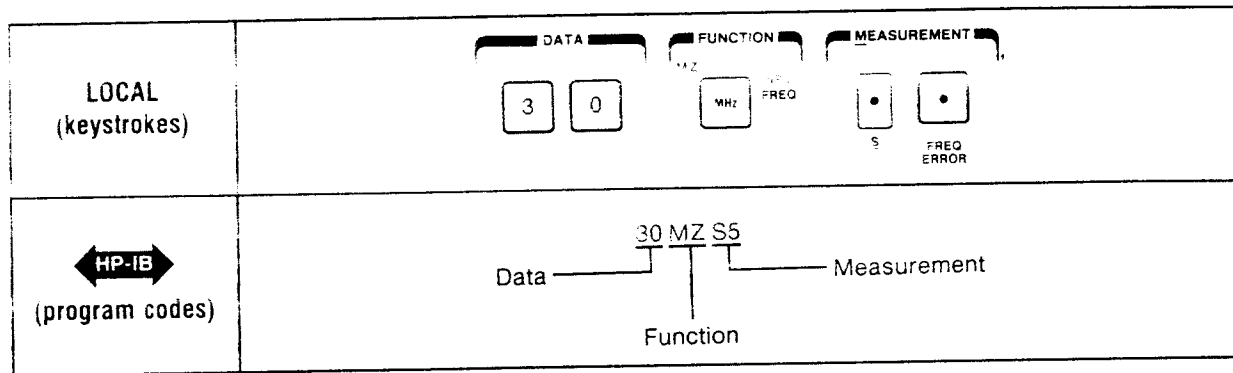

Indications

Display: When the FREQ ERROR key is pressed, the frequency error is displayed. The kHz annunciator lights.

Front Panel: The LEDs within the S (shift) and FREQ ERROR keys light.

Program Codes

FREQ ERROR = S5
MHz = MZ

Measurement Technique

When the Measuring Receiver is tuned, the IF signal is amplified and limited (when it has greater than 60 dB of gain). If manually tuned, the RF input frequency is determined (refer to RF Input Frequency) and compared to the keyboard-entered frequency, or to the frequency present when MHz was pressed. The difference is displayed as frequency error.

If the Measuring Receiver is automatically tuned, two methods of determining frequency error are used:

When the input signal is greater than 2.5 MHz, the frequency of the actual IF signal is subtracted from the selected IF frequency (455 kHz or 1.5 MHz) to determine the frequency error.

2-9. Mating Connectors

Interface Connector. The HP-IB mating connector is shown in Figure 2-3. Note that two securing screws are metric.

Coaxial Connectors. Coaxial mating connectors used with the Measuring Receiver should be the 50-ohm BNC male connectors or 50-ohm Type N male connectors that are compatible with those specified in US MIL-C-39012.

2-10. Operating Environment

The operating environment should be within the following limitations:

Temperature	0°C to +55°C
Humidity	<95% relative
Altitude	<4570 metres (15 000 feet)

2-11. Bench Operation

The instrument cabinet has plastic feet and fold-away tilt stands for convenience in bench operation. (The plastic feet are shaped to ensure self-aligning of the instruments when stacked.) The tilt stands raise the front of the instrument for easier viewing of the front panel.

2-12. Rack Mounting

WARNING

The Measuring Receiver is heavy for its size (23.6 kg, 52 lb). Care must be exercised when lifting to avoid personal injury. Use equipment slides when rack mounting.

Rack mounting information is provided with the rack mounting kits. If the kits were not ordered with the instrument as options, they may be ordered through the nearest Hewlett-Packard office. (Refer to paragraph 1-9, "Mechanical Options", in Section I). Before rack mounting the Measuring Receiver, the Operating Information pull-out tray (attached to the bottom of the instrument) must first be removed. To remove the pull-out card assembly, refer to steps "1" and "2" of the pull-out cards removal procedure that follows.

2-13. Removal and Installation of Operating Information Pull-Out Cards

Steps for Removal. Follow the procedure below to remove the Operating Information pull-out tray and the cards:

1. Remove the two front feet of the instrument.

RF Frequency Error

Description

The **FREQ ERROR** key enables the Measuring Receiver to measure the difference (in kHz) between the RF input signal frequency and the frequency to which the instrument is tuned. This function can be used to observe frequency drift of input signals, or to compare input frequencies against a keyboard-entered reference.

For down-converted signals, the down-converted RF input frequency must fall within the passband of the IF being used. For the 1.5 MHz IF, the passband is approximately 3 MHz wide. For the 455 kHz IF, the passband is approximately 200 kHz wide.

When the instrument is measuring frequency error, the output signal available at **MODULATION OUTPUT/AUDIO INPUT** represents the last modulation measurement made.

Display resolution is controlled by Special Function 7. (Refer to **RF Frequency Resolution**.)

Procedures

To make any frequency error measurement, connect the test signal to the Measuring Receiver's **RF INPUT** connector.

If a frequency drift measurement is to be made, first allow the Measuring Receiver to automatically tune to the signal, then press **MHz** to prevent retuning. Press the **S** (shift) and **FREQ ERROR** keys to display the frequency drift.

To make a frequency comparison, enter the reference frequency (in MHz) on the keyboard, then press the **MHz** key. Press the **S** (shift) and **FREQ ERROR** keys to display the difference frequency. The number is negative if the signal frequency is lower than the reference, and positive if the signal frequency is higher than the reference. Valid frequency error measurements are made as long as the down-converted signal remains in the IF passband. (Refer to **RF Frequency Tuning**.)

If frequency error is to be displayed relative to a reference, enter the value as a ratio reference using the **RATIO** key. (Refer to **Ratio**.)

Removal and Installation of Operating Information Pull-Out Cards
(Cont'd)

- 2. Remove the Operating Information tray assembly by sliding the tray toward the rear of the instrument and then down.
- 3. Remove the information cards by bowing them slightly in the middle and pulling it straight up (away from the tray).

Steps for Installation. Follow the procedure below to reinstall the Operating Information pull-out tray and cards:

- 1. Install the information card by bowing it slightly in the middle and carefully guiding the edges into the plastic guide slots near the front of the tray.
- 2. Push the information card all the way into the tray.
- 3. Place the information tray assembly between the rear feet of the instrument and slide it forward until the tabs are locked under the rear feet.
- 4. Replace the front feet of the instrument.

2-14. STORAGE AND SHIPMENT

2-15. Environment

The instrument should be stored in a clean, dry environment. The following environmental limitations apply to both storage and shipment:

Temperature -55°C to +75°C
 Humidity <95% relative
 Altitude <15 300 metres (50 000 feet)

2-16. Packaging

Original Packaging. Containers and materials identical to those used in factory packaging are available through Hewlett-Packard offices. If the instrument is being returned to Hewlett-Packard for servicing, attach a tag indicating the type of service required, return address, model number and full serial number. Also mark the container FRAGILE to assure careful handling. In any correspondence refer to the instrument by model number and full serial number.

Other Packaging. The following general instructions should be used for re-packaging with commercially available materials:

- 1. Wrap the instrument in heavy paper or plastic. (If shipping to a Hewlett-Packard office or service center, attach a tag indicating the service required, return address, model number and full serial number.)

Residual Noise Effects (Cont'd)

Theory (cont'd)

The residual noise reading made by the peak detector depends on the signal-to-noise ratio, as well as the statistics of the noise spikes and the response time of the specific peak detector. These factors are characterized by taking the ratio of the peak noise reading to the average noise reading. The average noise level is a truer determination of the actual amount of noise energy present, while the peak reading characterizes the peak detector and the statistics of the noise spikes.

Comments

The primary restriction placed on this method of accounting for residuals is that the noise must be gaussian (that is, statistically random). Periodic noise (for example, line-related noise) has repeating peaks and thus does not fall within the statistical model used to derive the nomograph given in the procedure.

Noise-peak-to-noise-average ratios greater than 4.4 indicate that there is probably a periodic component in the residual noise.

Both the modulation measurement to be corrected and the peak and average residual measurements to be used with the nomograph should be made on the same modulation range and with the same peak-detector-time-constant setting. Use the RANGE HOLD key while the instrument is measuring the modulated carrier; then measure the residuals once the ranges are held.

When factoring residual noise from peak ϕ M measurements made while using the 3 kHz LP FILTER, the readings may jump considerably. If this jumping occurs, use the highest of 10 successive readings (for both noise and signal-plus-noise) for the computations. (Use the PEAK HOLD key to hold the highest reading over a 2 second period.)

The residual noise contributions of the AM and FM calibrators and the Measuring Receiver are accounted for in the calibration procedures. It is not necessary to factor residual noise corrections into the calibration procedures described in this manual.

¹ Rice, S.O., "Statistical Properties of a Sine Wave Plus Random Noise", Bell System Technical Journal, 27, No.1, (January, 1948), pp. 109-157.

Packaging (Cont'd)

2. Use a strong shipping container. A double-wall carton made of 2.4 MPa (350 psi) test material is adequate.
3. Use enough shock-absorbing material (75 to 100 mm layer; 3 to 4 inches) around all sides of instrument to provide firm cushion and prevent movement in the container. Protect the front panel with cardboard.
4. Seal the shipping container securely.
5. Mark the shipping container FRAGILE to assure careful handling.

Residual Noise Effects (Cont'd)

Theory (con't)

A simplified diagram of the Measuring Receiver's peak detector is shown in the following figure. Whenever the signal-plus-noise voltage into the comparator exceeds the voltage stored on the output capacitor, C, the comparator closes the switch, S1. The capacitor is then charged via the path from +V through resistor, R. When the capacitor's charge exceeds the incoming signal voltage, the comparator opens the switch again. This process continues until the voltage on the capacitor is transferred to the voltmeter through the sample-and-hold switch, S2. C is then discharged by S3. When very narrow noise spikes are imposed on the comparator's input, the circuit's RC time constant will not allow the capacitor to fully charge before the noise peak has passed.

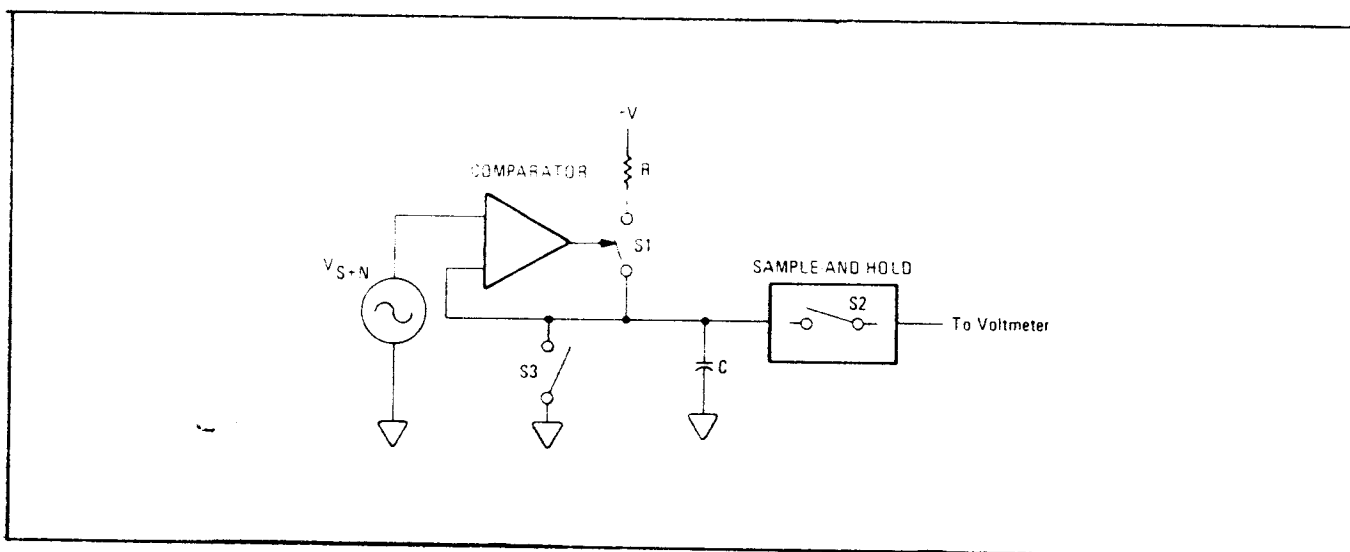

Simplified Measuring Receiver Peak Detector Output

When noise alone is imposed on the detector, it is very probable that, as C begins to charge, a noise spike will exceed the charge that exists on the peak detector capacitor. However, as the capacitor's charge more closely approximates the peak noise level, this probability decreases. Thus the peak detector, over a significantly long time, can faithfully measure fairly-high peak noise levels.

When noise is riding on a sinewave, only the signal-plus-noise peaks exceeding the sinusoid's peak level can add charge to the peak detector capacitor. Statistically, there is less of a chance that the total input signal will exceed the charge on the capacitor (already set to the peak sinewave amplitude) when measuring a sinewave than when measuring only noise. Thus, the contribution of noise on the measured peak modulation level decreases with an increase in the signal-to-noise ratio.¹ To simply measure the peak residual noise present when the baseband drive is removed and subtract the result directly from the peak reading of the combined input, over-compensates the measurement results.

SECTION III

OPERATION

3-1. INTRODUCTION

3-2. General

This section provides complete operating information for the Measuring Receiver. Included in this section are descriptions of all front- and rear-panel controls, connectors, and indicators, remote and local operator's checks, operating instructions, and operator's maintenance.

3-3. Operating Characteristics

The major operating characteristics of the Measuring Receiver are provided in paragraph 1-6 "Description", Table 1-1 "Specifications", and Table 1-2, "Supplemental Information". For information on HP-IB capabilities, refer to paragraphs 3-12 through 3-31.

3-4. Turn-On Procedure

WARNING

Before the Measuring Receiver is switched on, all protective earth terminals, extension cords, auto-transformers, and devices connected to it should be connected to a protective earth socket. Any interruption of the protective earth grounding will cause a potential shock hazard that could result in personal injury.

For continued protection against fire hazard, replace the line fuse with a 250V normal blow fuse of the same rating. Do not use repaired fuses or short-circuited fuseholders.

CAUTION

Before the Measuring Receiver is switched on, it must be set to the voltage of the power source, or damage to the instrument may result. Refer to paragraph 2-4.

Do not apply greater than 40V (ac + dc) to the RF INPUT connector or damage to the instrument may result.

The Measuring Receiver has a standby state and an on state. Whenever the power cable is plugged in, an internal power supply is activated. In instruments supplied with the high-stability reference (Option 002) the supply energizes the internal reference oven. If the

Residual Noise Effects (Cont'd)

Theory

Residual noise is a measurement of the short-term amplitude or phase (and thus frequency) instability inherent in any CW signal source. In a measurement system composed of a signal source and the Measuring Receiver, residual noise is contributed by both instruments. When modulation is measured with the Measuring Receiver, both the intended modulation and the residual modulation are measured in combined form. To determine the precise amount of modulation produced by a signal source as a result of the application of a baseband or modulating signal, the effects of residual noise must be factored out of the measurement results.

Two noise components are commonly encountered in modulation measurements: periodic (often line related) and gaussian (random). Periodic noise and the baseband signal behave identically. Thus the Measuring Receiver measures the arithmetic sum of the peak or average levels of the two signals (according to the detector selected). To determine the actual modulation that can be attributed to the baseband input, simply subtract out the peak-periodic residual.

The effects of random noise on our measurement system are not nearly so straight forward. True random noise, when viewed in the frequency domain, is a continuous spectrum of frequencies at various amplitudes. Indeed, the frequency of the noise spectrum is limited only by the bandwidths of the observing and/or generating devices. In the time domain, noise of this kind appears as random amplitude spikes (or fuzz) riding on top of the recovered baseband signal. The amplitude of these spikes is limited by the slow rate of the observing and/or generating devices. Peak detecting these spikes exaggerates the amount of energy present in the noise spectrum so noise measurements are typically made with average-responding detectors and with limited bandwidths.

The measurement problem arises because we typically express modulation level as a peak function. To account for residuals in these peak measurements, the actual effects of the noise on the Measuring Receiver's peak detector must be determined.

Turn-On Procedure (Cont'd)

Measuring Receiver is already plugged in, set the POWER switch to ON. If the power cable is not plugged in, follow these instructions:

1. Check that the line voltage setting matches the power source. (See Figure 2-1.)
2. Check that the fuse rating is appropriate for the line voltage used. (See Figure 2-1.) Fuse ratings are provided in the paragraph "Operator's Maintenance" in this section.
3. Plug in the power cable.
4. Set the POWER switch to ON.

NOTE

When the POWER switch is set to ON, all front-panel indicators light for approximately 10 seconds after which the instrument is ready to be operated.

3-5. Local Operation

Information regarding front-panel operation of the Measuring Receiver is provided in the sections described in the following paragraphs. To most rapidly learn the basic operation of the instrument, perform the Operator's Checks. Once familiar with the general operation of the instrument, use the Detailed Operating Instructions for the most in-depth and complete information on operating the Measuring Receiver.

Panel Features.

Front-panel controls, indicators, and connectors are illustrated and described in Figure 3-1. This figure describes the various functions of the Measuring Receiver and summarizes briefly how to use them.

Rear-panel features are shown and described in Figure 3-2. The figure provides a quick reference for rear-panel signal levels and frequencies and also includes the impedances at the rear-panel connections.



The information in parenthesis at the end of each feature summary provides the title of the Detailed Operating Instructions relevant to the feature.

Detailed Operating Instructions. The Detailed Operating Instructions provide a complete operating reference for the Measuring Receiver user. The instructions are organized alphabetically by subject. Not only do the instructions contain information on the various measurements that can be made (listed under titles such as AM, FM, PM, RF Frequency, RF Power, Audio Frequency, etc.), but there are also individual discussions of nearly all controls, inputs, and outputs. Also



Residual Noise Effects (Cont'd)

Example (cont'd)

- Disable auto-ranging by pressing the RANGE HOLD key:

LOCAL (keystrokes)	RANGE HOLD 
 (program codes)	G1 Range Hold

- Remove the baseband signal from the modulation input of the signal generator and read the peak residual modulation, N_{pk} ; for example, 0.07%.
- Measure the average residual modulation:

LOCAL (keystrokes)	
 (program codes)	D4 Detector

For example, the average residual modulation might read 0.02%.

- Compute $\frac{N_{pk}}{N_{pk}} = \frac{0.07\%}{0.02\%} = 3.5$
- Compute $\frac{(S+N)_{pk}}{N_{pk}} = \frac{30.80\%}{0.07\%} = 440$
- Using the nomograph, $N\%$ is found to be 26%.
 Compute $S_{pk} = (S+N)_{pk} - N_{pk} (N\%) = 30.80\% - 0.07\% \times 0.26 = 30.78\%$

NOTE

This correction factor of <0.1% of the peak reading is typical of a modulation measurement of a quality modulation source measured with the 15 kHz low-pass filter.

Local Operation (Cont'd)

included are instructions for using the many User Special Functions. A guide to using the Detailed Operating Instructions is provided ahead of the instructions themselves.

Operating Information Pull-Out Cards. The Operating Information pull-out cards are flexible plastic reference sheets attached to the Measuring Receiver by a tray located below the front panel. They contain a brief summary of front-panel operation and displays. Also included on the cards is a complete listing of HP-IB codes, data, and error output formats; as well as Error codes, and User Special Functions. The cards show a simplified block diagram for the Measuring Receiver and provide basic instructions for RF Power and Tuned RF Level Measurement operation. The pull-out cards are intended to be a reference for the user who already has a basic understanding of front-panel operation; however, sufficient information is included to allow the first-time user to successfully make accurate measurements.

Supplemental Information. Other information, pertinent to operating the Measuring Receiver to its fullest capabilities, are contained in Section I. Principles of Operation for a Simplified Block Diagram (in paragraph 1-15) is a fundamental description of what the Measuring Receiver is and how it works. This information supplements the block diagrams provided on the pull-out card and in the Detailed Operating Instructions. It also provides a basis for applying the Measuring Receiver to various measurement situations.

3-6. Remote Operation

The Measuring Receiver is capable of remote operation via the Hewlett-Packard Interface Bus (HP-IB). Provided in this section are instructions pertinent to HP-IB operation including all considerations and instructions specific to remote operation (including capabilities, addressing, input and output formats, the status byte, and service requests). At the end of the discussion is a complete summary of all codes and formats.

HP-IB information concerning remote information also appears in several other locations. Address setting is discussed in Section II. A summary of HP-IB codes and output formats appears on the Operating Information pull-out card, and numerous examples of program strings appear throughout the Detailed Operating Instructions described in the paragraph, "Local Operation" in this section.

3-7. Operator's Checks

Operator's Checks are simple procedures designed to verify the proper operation of the Measuring Receiver's main functions and to familiarize the first-time operator with basic Measuring Receiver measurement capabilities. Two procedures are provided:

Basic Functional Checks. This procedure requires only a sensor module, a signal generator, an oscilloscope, and interconnecting cables and adapters. It assures that most front-panel controlled functions are being properly executed by the Measuring Receiver.

Residual Noise Effects (Cont'd)

Procedure (cont'd)

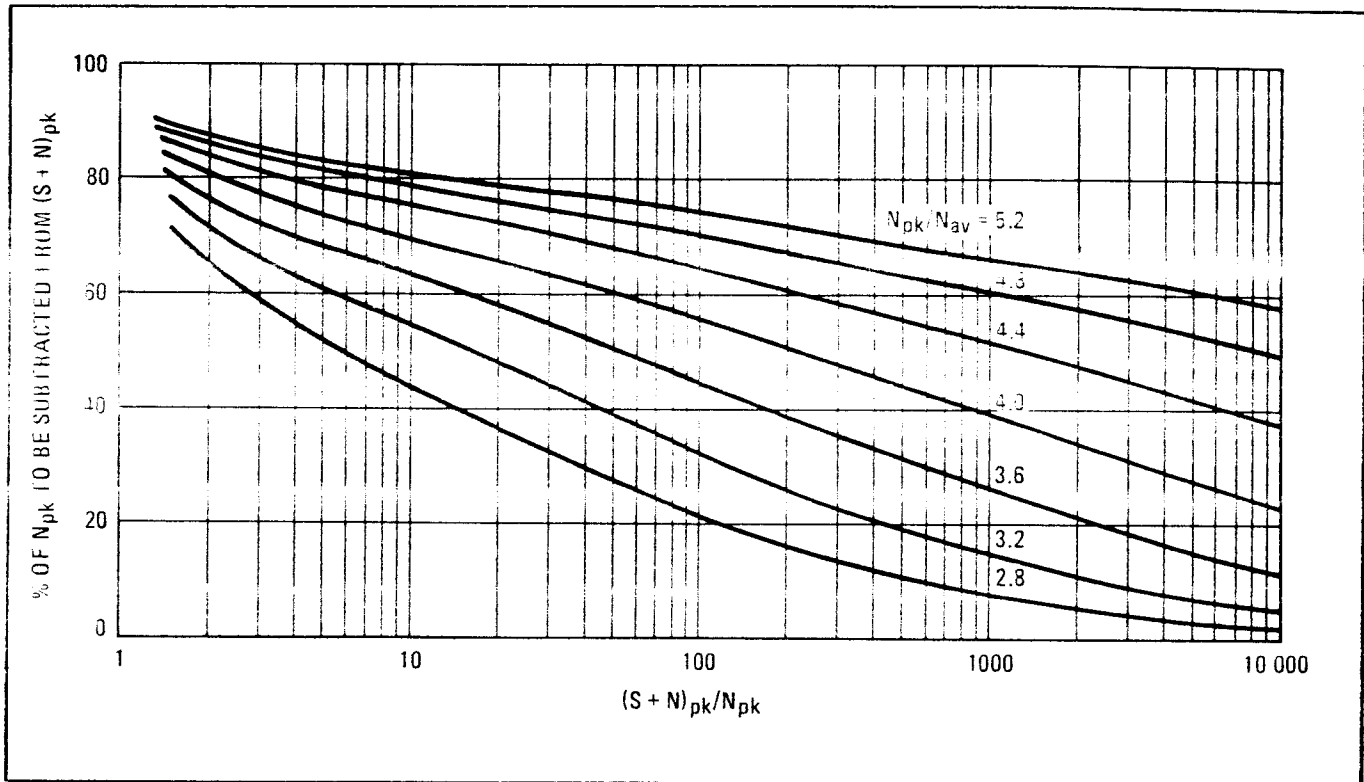

Nomograph for Calculating Percentage of N_{pk} to be Subtracted from $(S+N)_{pk}$ to obtain S_{pk} (Sine Wave)

Example

To determine the actual peak AM depth (measured in a 15 kHz bandwidth) resulting from the application of a 1 Vpk, 1 kHz baseband signal to the modulation input of a signal generator:

1. Measure the peak modulation depth, $(S+N)_{pk}$:

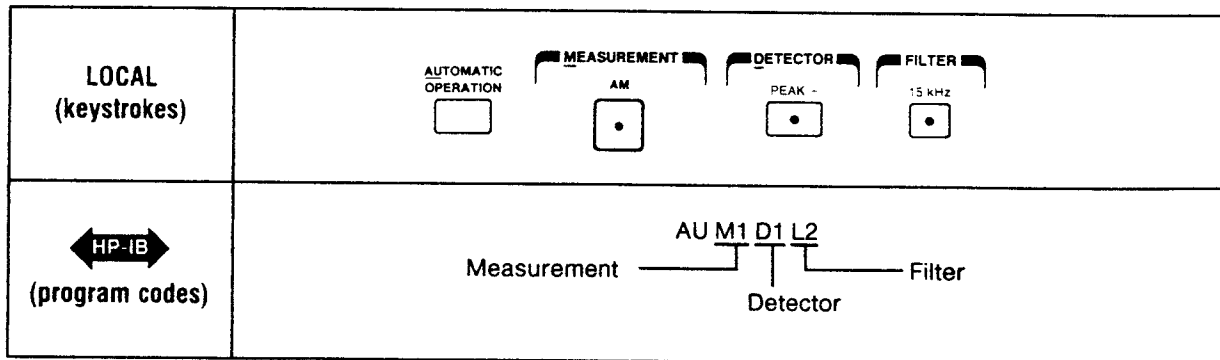

For example, 30.80% might be displayed.

Operator's Checks (Cont'd)

HP-IB Functional Checks. This series of procedures requires only an HP-IB compatible computing controller and an HP-IB interface and connecting cable. The HP-IB Functional Checks assume that front-panel operation has been verified (for example, by performing the Basic Functional Checks).

3-8. Operator's Maintenance**WARNING**

For continued protection against fire hazard, replace the line fuse only with a 250V normal blow fuse of the same rating. Do not use repaired fuses or short-circuited fuseholders.

The only maintenance the operator should normally perform is the replacement of the primary power fuse located within the Line Power Assembly (A30). For instructions on how to change the fuse, refer to Figure 2-1, steps 1 and 3.

Fuses can be ordered using HP Part Number 2110-0083, 2.5A (250V, normal blow) for 100/120 Vac operation or 2110-0043, 1.5A (250V, normal blow) for 220/240 Vac operation.

Residual Noise Effects

Description

When making peak-modulation measurements of the highest accuracy, it is necessary to characterize and factor out the effects of residual noise on the measurement. The procedure outlined in this Detailed Operating Instruction describes a technique for quantifying and removing residual noise effects on peak modulation measurements.

Procedure

The following procedure enables the user to make a corrected, peak-modulation measurement.

1. Set up and make a normal signal-plus-noise peak measurement, $(S+N)_{pk}$.
2. Press the RANGE HOLD key to prevent autoranging. If filtering and (or) de-emphasis was used in step one, make all the following measurements with the same settings.
3. Remove the baseband drive to the modulator, and measure the peak residual noise level, N_{pk} .
4. Measure the average residual noise level, N_{av} , using the average detector.
5. Compute $\frac{(S+N)_{pk}}{N_{pk}}$ and $\frac{N_{pk}}{N_{av}}$.
6. Use the nomograph to determine the percent, $N\%$, of the peak residual noise level, N_{pk} , to be subtracted from the peak-measured signal plus noise, $(S+N)_{pk}$.
7. Compute the true, peak signal where:

$$S_{pk} = (S+N)_{pk} - N_{pk} (N\%),$$

and $N\%$ is expressed as a ratio.

ration

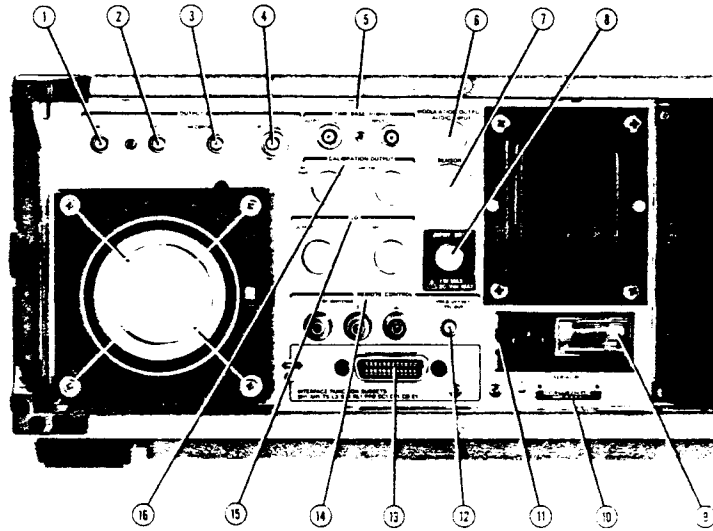

Figure 3-2. Rear-Panel Features

Remote Control RF Switch (Cont'd)

Comments

These rear-panel voltages are not intended as "general purpose" switch drives. The connectors are to be used only for user-built sensor modules.

Related Functions

RF Power
Tuned RF Level

- 1 The switches listed are those available at the time of the copyright date of this manual.

Front-Panel Features

The following list provides a brief description of each feature. The information in parenthesis provides the title of the Detailed Operating Instructions relevant to the feature.

- ① **MEASUREMENT** keys enable the Measuring Receiver to make and display the selected measurement. (AM, FM, ϕ M, RF Power, RF Input Frequency, Audio Frequency, Audio Distortion and Level, IF Level, Tuned RF Level, RF Frequency Error)
- ② **Numeric Display** shows measurement results, error codes, or instrument or Special Function status.
- ③ **Display Annunciators** indicate the measurement result units. They also indicate that some measurement functions are enabled. All these annunciators are displayed when the Measuring Receiver is first turned on.
- ④ **AUTOMATIC OPERATION** enables the Measuring Receiver to automatically tune and autorange to make the selected measurement. (Automatic Operation)
- ⑤ **INSTR PRESET** (Blue Key) configures the Measuring Receiver to its power-up condition. (Instrument Preset)
- ⑥ **TRACK MODE** (Blue Key) and **AUTO TUNING** (Blue Key) select the tuning mode of the Measuring Receiver. (RF Frequency Tuning)
- ⑦ **STORE** (Blue Key) and **RECALL** (Blue Key) enable the Measuring Receiver to store and recall up to eight measurement states. (Store/Recall)
- ⑧ **WATTS**, **uV**, **mV**, and **VOLTS** keys (all used with the Blue Key) enable selection of different units for level measurements.
- ⑨ **MHz** completes the keyboard entry of frequencies for various functions. (RF Frequency Tuning, Frequency Offset Mode)
- ⑩ **MODULATION OUTPUT/AUDIO INPUT** connector provides either an output for the modulation recovered from the RF INPUT connector, or an input for external audio signals to be processed by the audio circuitry. The MODULATION OUTPUT LEDs indicate the type of recovered modulation available as the output. The AUDIO INPUT key selects whether the internally demodulated signal or an external audio signal is to be processed by the Measuring Receiver's audio circuitry. (Modulation Output/Audio Input, Audio Frequency, Audio Distortion and Level, SINAD)

Remote Control RF Switch (Cont'd)

Procedure (cont'd)

(The switch's port C is intended as an input from the device-under-test.)

Connect the power sensor to the SENSOR input, and the other end of the RF coaxial cable to the RF INPUT of the Measuring Receiver.

Proceed with selected measurements. This user-built module will enable the Measuring Receiver to automatically switch between its inputs as selected measurements require.

Block Diagram

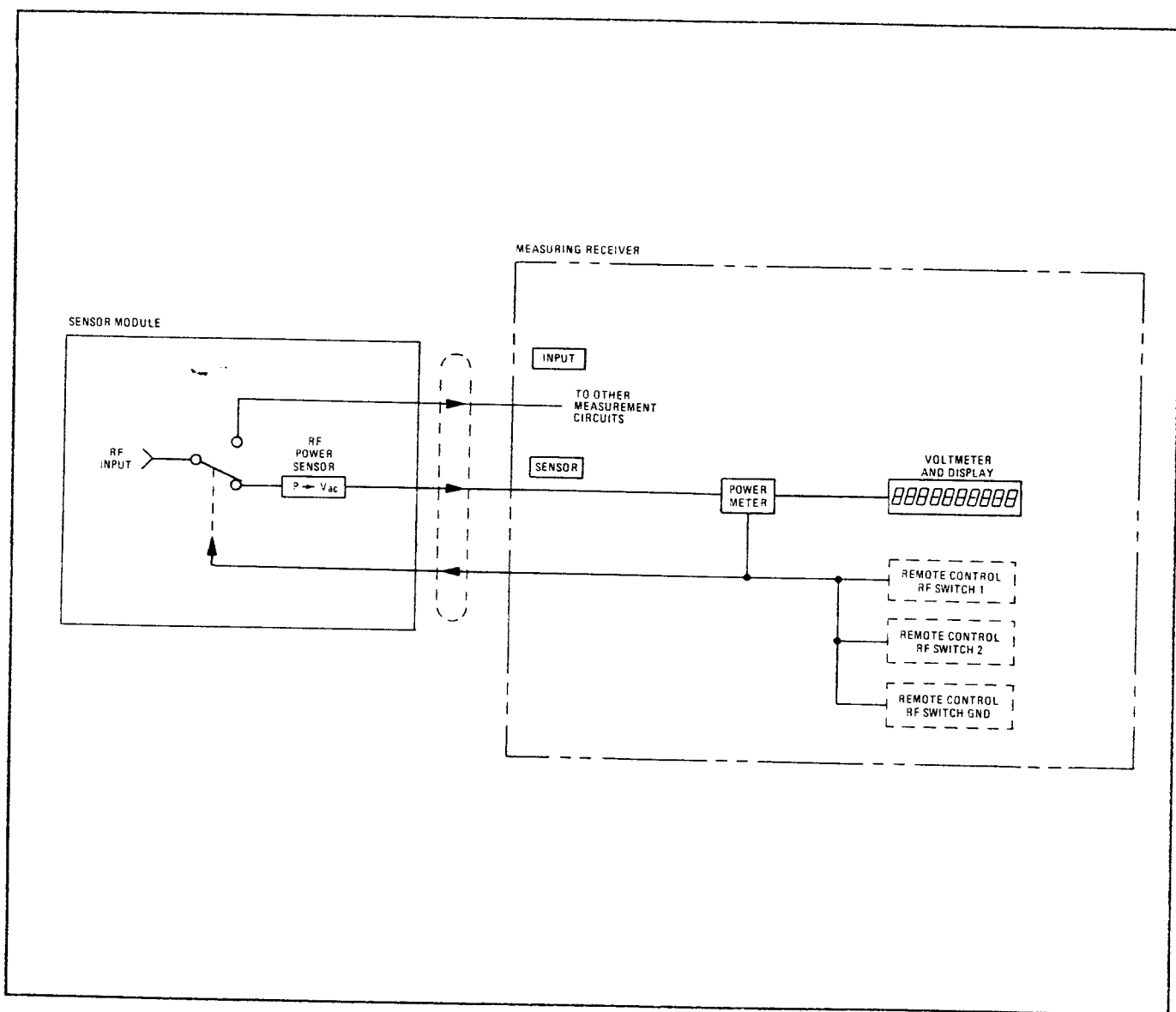

Block Diagram of Remote Control RF Switch

- ⑪ % CAL FACTOR (Blue Key) causes the Measuring Receiver to display the current calibration factor for the selected measurement. This key is also used to complete the entry of calibration factors for various functions. (AM Calibration, FM Calibration, RF Power Calibration Factors, Tuned RF Level Calibration and Calibration Factors)
- ⑫ DISPLAY FREQ (Blue Key) causes the Measuring Receiver to display the RF frequency that it tuned to last. (Frequency Offset Mode, RF Power Calibration Factors)
- ⑬ SENSOR connector provides the input for the power sensor. (RF Power)
- ⑭ kHz \uparrow (Blue Key) and kHz \downarrow (Blue Key) complete keyboard entry of frequency step-size (in kHz) for step tuning, or change the frequency in the increments specified. (RF Frequency Tuning)
- ⑮ DISPLAY FREQ INCR (Blue Key) causes the Measuring Receiver to display the increment step-size. (RF Frequency Tuning)
- ⑯ INPUT couples the RF input signal into the instrument. (RF Input Frequency)
- ⑰ SPCL completes entry of Special Function codes that access additional instrument operations. Without a preceding numeric entry, the SPCL key causes a display of the status of Special Functions 1 through 10. (Special Functions)
- ⑱ (-) (Blue Key) enables input data to be entered as a negative value.
- ⑲ RANGE HOLD freezes the current ranges being used by the Measuring Receiver. (Range Hold)
- ⑳ Blue Key is a shift key that enables some keys to have two different functions. Any function printed in blue can be selected when the key associated with it is pressed after the Blue Key. The Blue Key flashes at the current measurement rate whenever it is pressed.
- ㉑ DISABLE ERROR (Blue Key) disables Error 01 through Error 04. (Disable Error Message Control)
- ㉒ LOG/LIN causes measurements to alternate between logarithmic and linear units. (Ratio and Log/Lin)
- ㉓ dB EXT ATTEN (Blue Key) enables level measurements to be offset with external attenuation or gain. (External Attenuation)
- ㉔ RATIO (Blue Key) and PREVIOUS RATIO (Blue Key) cause the current measurement to be compared to a reference. (Ratio and Log/Lin)

Remote Control RF Switch

Description

An external power sensor is required for making accurate RF power and tuned RF level measurements. A standard HP Power Sensor (HP 8480 series) can be configured in any of the following ways:

A power sensor alone.

A sensor module (such as the HP 11722A) that contains a power sensor (a specific power sensor depending on the HP Model Number of the sensor module) and an RF coaxial, type-N connector/cable. The Measuring Receiver controls an RF switch in the sensor module to automatically switch between RF INPUT and SENSOR as selected measurements require.

A sensor module, built by the user, that includes any HP 8480 series power sensor, an RF cable, and an HP switch (HP 33311 or HP 8761¹). The REMOTE CONTROL RF SWITCH rear-panel outputs enable the Measuring Receiver to drive the external switch in the user-built sensor module. This user-built module also enables the Measuring Receiver to automatically switch between RF INPUT and SENSOR as selected measurements require.

Procedure

The following procedure enables the user to create a remotely-controlled sensor module:

Select a control switch. Either the HP 33311B, Option 011 (5V solenoid) or the HP 8761A (12-15V solenoid) can be used¹.

Connect the Measuring Receiver's REMOTE CONTROL RF SWITCH outputs to the control switch:

For the HP 33311B, Option 011:

Connect REMOTE CONTROL RF SWITCH 1 to the switch (1-).
Connect REMOTE CONTROL RF SWITCH 2 to the switch (2-).
Connect REMOTE CONTROL RF SWITCH GND to the switch (C+).

For the HP 8671A:

Connect REMOTE CONTROL RF SWITCH 1 to the switch (+).
Connect REMOTE CONTROL RF SWITCH 2 to the switch (-).
Leave REMOTE CONTROL RF GND disconnected.

Connect the power sensor input to port 1 of the selected switch.

Connect the RF coaxial cable to port 2 of the selected switch.

Operation

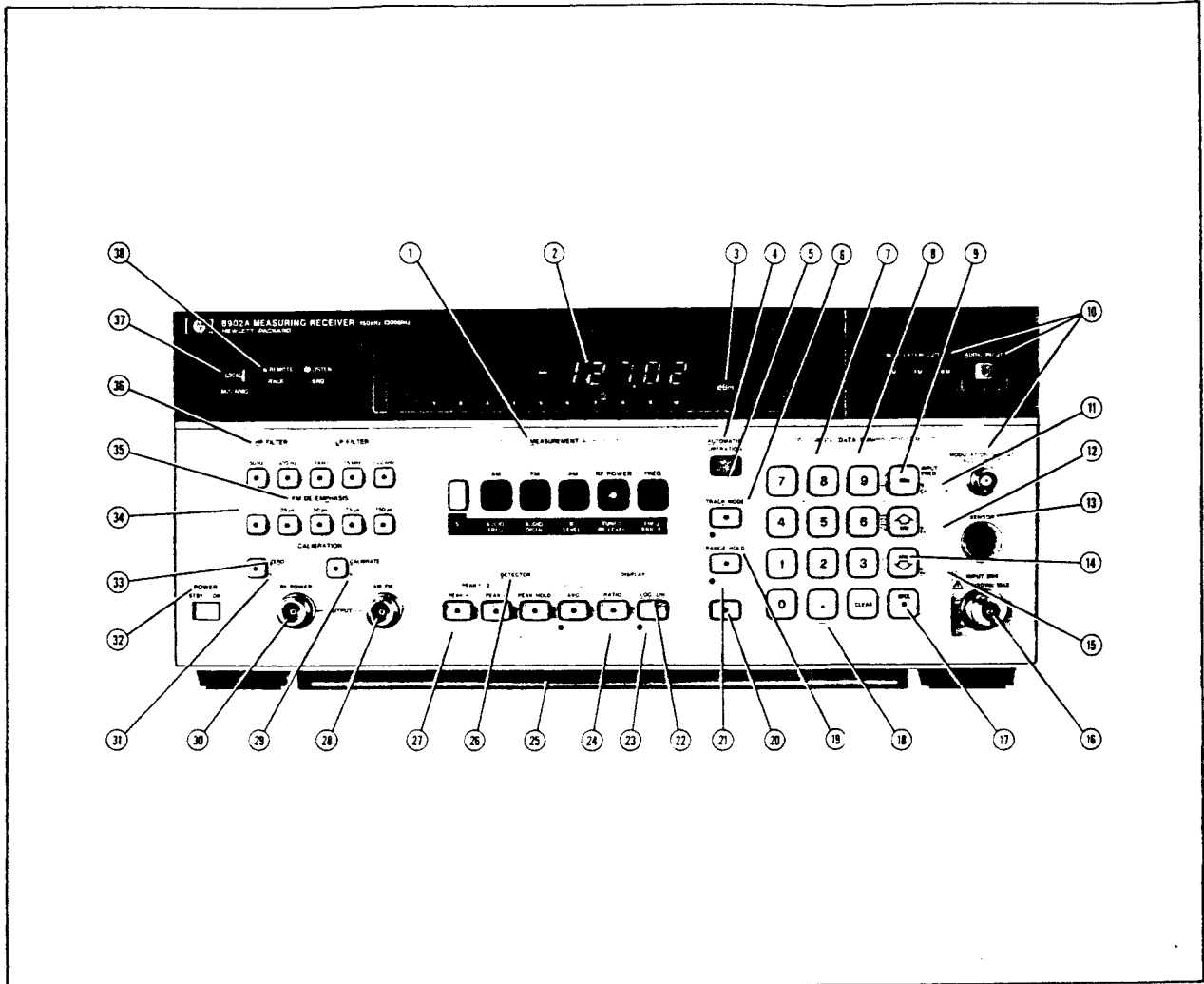

Figure 3-1. Front-Panel Features

Recorder Output (Cont'd)
(Includes Special Functions 49 and 50)

When making a relative level measurement over a 10 dB (or smaller) level change, the excellent linearity of the IF Synchronous detector can be taken advantage of by doing the following:

Lock up the IF Synchronous detector to the input signal, and apply the following formula:

Level Change in dB =

$$\Delta dB = 20 \log \frac{(50.06 \text{ SPCL @ high level}) - (50.06 \text{ SPCL w/ 48.1 SPCL enabled})}{(50.06 \text{ SPCL @ low level}) - (50.06 \text{ SPCL w/ 48.1 SPCL enabled})}$$

Related Functions

RF Power
RF Power Calibration
RF Power Calibration Factors
Special Functions
Tuned RF Level

Rear-Panel Features

- ① **AM OUTPUT** produces an ac signal, whose amplitude is proportional to the AM depth, with a dc component related to the IF level. The output is dc coupled with a 16 kHz bandwidth and a 10 kohm output impedance. (AM Output)
- ② **FM OUTPUT** produces an ac signal, whose amplitude is proportional to the FM deviation, with a dc component related to the IF frequency. The output is dc coupled with a 16 kHz bandwidth and a 10 kohm output impedance. (FM Output)
- ③ **RECORDER OUTPUT** allows user-access to all internal measurement voltages. (Recorder Output)
- ④ **IF OUTPUT** produces a 150 kHz to 2.5 MHz modulated IF signal. The output level ranges from -27 to -3 dBm (50 ohm output impedance). (IF Output)
- ⑤ **TIME BASE 10 MHz OUTPUT and INPUT.** The input connector provides an input for an external 10 MHz time base reference. The external input signal must be greater than 0.5V peak-to-peak (into a 500 ohm input impedance). The output connector provides an output for the internal, high-stability 10 MHz reference. Output signal is TTL compatible (50 ohm nominal output impedance). (Time Base 10 MHz Input and Time Base 10 MHz Output)
- ⑥ **MODULATION OUTPUT/AUDIO INPUT** is a rear-panel output and input supplied on Option 001 instruments instead of the standard, front-panel connection. Refer to MODULATION OUTPUT/AUDIO INPUT in Figure 3-1.
- ⑦ **SENSOR** is a rear-panel input for the power sensor supplied on Option 001 instruments instead of the standard, front-panel connection. See SENSOR in Figure 3-1.
- ⑧ **INPUT** is a rear-panel input for the RF input signal. This input is supplied on Option 001 instruments instead of the standard front-panel connection. See INPUT in Figure 3-1.
- ⑨ **Fuse.** 2 1/2 Amp (250V, Normal Blow) for 100/120 Vac.
1 1/2 Amp (250V, Normal Blow) for 220/240 Vac.
- ⑩ **Serial Number Plate.** First four numbers and letter comprise the prefix that denotes the instrument configuration. The last five digits form the suffix that is unique to each instrument.
- ⑪ **Line Power Module** permits operation from 100, 120, 220, or 240 Vac. The number visible in the window indicates the nominal line voltage to which the instrument must be connected. (See Figure 2-1.) The center conductor is safety earth ground.

Recorder Output (Cont'd)
(Includes Special Functions 49 and 50)

Procedure

To make an RF power measurement at the RECORDER output, connect a high-accuracy, linear voltmeter to that output. Connect the RF signal to be tested to the RF INPUT and SENSOR input. (This assumes use of the HP 11722A Sensor Module. If a different power sensor is to be used, refer to RF Power and Tuned RF Level for usage instructions.)

CAUTION

When using the RECORDER output to measure RF power, care must be taken to note the effects of voltmeter load impedance and Operational Amplifier bias currents on the Voltmeter Assembly; depending on required accuracy, these factors might scale or offset the voltage read from what the instrument would use to calculate RF power measurements.

Key in the appropriate Special Function as listed in "Description".

The voltage that is proportional to the input power is displayed on the external voltmeter. To interpret the output voltage, a few measurements should be taken to characterize the measurement circuitry before an actual measurement is taken. Measure the voltage out the RECORDER output when zero input power is at the SENSOR input. Note the voltage value. Press the RANGE HOLD key. Now measure the voltage at the RECORDER output with a known input power (for example, 1 mW). Once these two voltages are known, any voltage obtained from an unknown input level can be interpolated.

Comments

For any value 49.PQ or 50.PQ, if P is not equal to 0 or 8 (normal operation), the Measuring Receiver displays $V_p - V_q$ and the controller saves V_q as V_{ref} for the P = 0 or 8 case: If P = 0 or 8, ("recorder" operation), the Measuring Receiver displays $V_q - V_{ref}$ and delivers V_q out the RECORDER output for user access.

Normally, the Measuring Receiver will measure voltages, apply an appropriate formula, and massage the number to display the appropriate measurement value in the appropriate units. Instead of using these formulas, the user can take a ratio of any two measurements to obtain relative measurement information.

- ⑫ **FREQ OFFSET TTL OUT** outputs a voltage that can be used to switch an external mixer in and out of the path between a microwave input signal and the Measuring Receiver when the instrument is in Frequency Offset Mode. The TTL output is always 0V if Frequency Offset Mode is not selected or while Frequency Offset Mode is selected with an entered external LO value of 0 Hz. If the entered external LO frequency of the Measuring Receiver is less than or equal to 18 GHz, the TTL output is +5V. If the entered external LO frequency is greater than 18 GHz, the TTL output is 3V. (Frequency Offset Control)
- ⑬ **HP-IB Connector** connects the Measuring Receiver to the Hewlett-Packard Interface Bus for remote operations. When the HP-IB is being used, the LEDs next to the HP-IB turns on the front-panel light as appropriate (REMOTE, LISTEN, TALK, SRQ).
- ⑭ **REMOTE CONTROL RF SWITCHES** enable the user to build an external sensor module that can switch between the RF INPUT connector and the SENSOR connector. (Remote Control RF Switch)
- ⑮ **LO OUTPUT and INPUT** (Option 003 only). The LO output connector provides an output for the Local Oscillator. The output signal is 1.27 to 1301.5 MHz at approximately 0 dBm (50 ohm.) nominal output impedance. The LO input connector provides an input for an external Local Oscillator. External input signal required is 1.27 to 1301.5 MHz at approximately 0 dBm (50 ohm nominal input impedance). (LO Input and LO Output)

CAUTION

Do not apply reverse power into the LO OUTPUT or damage to the instrument may result. Do not apply greater than 40 Vdc or +5 dBm of RF power into the LO INPUT or damage to the instrument may result.

- ⑯ **CALIBRATION OUTPUT RF PWR and AM/FM** produces a rear-panel output for RF Power and AM and FM calibrators. This output is supplied on Option 001 instruments instead of the standard front-panel connection. Refer to both CALIBRATION RF POWER OUTPUT and CALIBRATION AM/FM OUTPUT in Figure 3-2.

Recorder Output (Includes Special Functions 49 and 50)

Description

The RECORDER output yields the voltage that is being read by the internal voltmeter.

Since the internal voltmeter takes many different readings to interpret a measurement, only pulses are available at this output under normal conditions. An oscilloscope, connected to this output, could prove to be very useful in monitoring the signal or in troubleshooting an instrument malfunction.

Using Special Functions 49 and 50, specific measurement voltages can be delivered out the RECORDER output to be read by an external, high-accuracy, linear voltmeter. This method enables better resolution on all measurements and better accuracy in RF power and tuned RF level measurements because the slight, dc offset and non-linearity of the internal voltmeter can be bypassed.

The following Special Functions can be used to effectively "freeze" the instrument (no ranging, retuning, etc.) and deliver a dc level that is proportional to a particular measurement value:

Special Function	Measurement Voltage Delivered Out Recorder Output
49.00 SPCL	Ground
49.01 SPCL	RF Peak Detector Ground
49.02 SPCL	RF Peak Detector Output/2.96
49.03 SPCL	RF Peak Detector
49.04 SPCL	10 x AM Calibrator Level
49.05 SPCL	AM Calibrator Level
49.06 SPCL	Audio Range Detector
49.07 SPCL	Audio RMS Detector
49.08 SPCL	Ground
49.09 SPCL	Audio AVG Detector
49.0A SPCL (A = S (shift), 0)	Audio PEAK Detector
49.0B SPCL (b = S (shift), 1)	IF Average Detector
49.0D SPCL (d = S (shift), 3)	IF Peak Detector
49.0E SPCL (E = S (shift), 4)	ALC Current
49.0F SPCL (F = S (shift), 5)	Power Meter*
50.06 SPCL	IF Synchronous Detector (pre-rms)
50.07 SPCL	IF Synchronous Detector (post-rms)

*Power Meter: Preceded with 0.211 SPCL to read sensor-type voltage, 0.212 SPCL to read voltage from the output filter on the Power Meter Assembly. Note these 0. Special Functions also determine the state of the RF power calibrator and sensor module input switch read relays.

- ②5 Operating Information pull-out cards are quick operating references that list Special Function, HP-IB, and Error codes, show a simplified block diagram for the Measuring Receiver, and provide basic information for RF Power and Tuned RF Level operation.
- ②6 DETECTOR keys select the audio detector used to measure the modulation. Positive peak, negative peak, average (rms calibrated), or true rms (Blue Key) detectors are available. Positive or negative peak values can be captured using the Peak Hold function. (Audio Detectors, Audio Distortion and Level, SINAD)
- ②7 1 kHz DISTN (Blue Key) and 400 Hz DISTN (Blue Key) enable the Measuring Receiver to make audio measurements on either 1 kHz or 400 Hz audio signals. (Audio Distortion and Level, SINAD)
- ②8 CALIBRATION AM/FM OUTPUT makes available a precisely modulated signal used to improve the Measuring Receiver's AM or FM accuracy. (AM Calibration, FM Calibration)
- ②9 CALIBRATE and SAVE CAL (Blue Key) enable the Measuring Receiver to calibrate and save the resultant calibration factor for either RF Power, AM, or FM. The CALIBRATE key also initiates tuned RF level calibration operations. (AM Calibration, FM Calibration, RF Power CALibration, Tuned RF Level Calibration and Calibration Factors)
- ③0 CALIBRATION RF POWER OUTPUT makes available a 50 MHz, 1 mW power reference used to precisely determine the sensitivity of the external power sensor. (RF Power Calibration)
- ③1 SET REF (Blue Key) enables the Measuring Receiver to accurately measure relative power changes; for example, in attenuator or amplifier measurements. (Attenuator Measurements)
- ③2 POWER switch applies power to the Measuring Receiver when set to ON. (Instrument Preset)
- ③3 ZERO causes the Measuring Receiver to cancel any dc offset that may be present in the power sensor. (RF Power Calibration)
- ③4 PRE DISPLAY enables FM deviation to be measured before or after de-emphasis. (FM De-Emphasis)
- ③5 FM DE-EMPHASIS networks equalize pre-emphasized FM. (FM De-Emphasis)
- ③6 HP (High-Pass) and LP (Low-Pass) FILTERS limit the demodulated signal bandwidth. (Audio Filters)
- ③7 LOCAL returns the Measuring Receiver to keyboard control from remote (HP-IB) control.
- ③8 HP-IB Annunciators indicate remote operation status.

Ratio and Log/Lin (Cont'd)
(Includes the PREVIOUS RATIO key and Special Function 11.2)

- 1 When watts units are used, this equation provides the ratio result for RF POWER, TUNED RF LEVEL, and RF LEVEL (35.0 SPCL) measurements.
- 2 When uV, mV, or V units are used, this equation provides the ratio result for RF POWER, TUNED RF LEVEL, and RF LEVEL (35.0 SPCL) measurements.

OPERATOR'S CHECKS

3-9. OPERATOR'S CHECKS

3-10. Basic Functional Checks

Description

Using a signal generator, an oscilloscope, and a sensor module, the overall operation of the Measuring Receiver is verified.

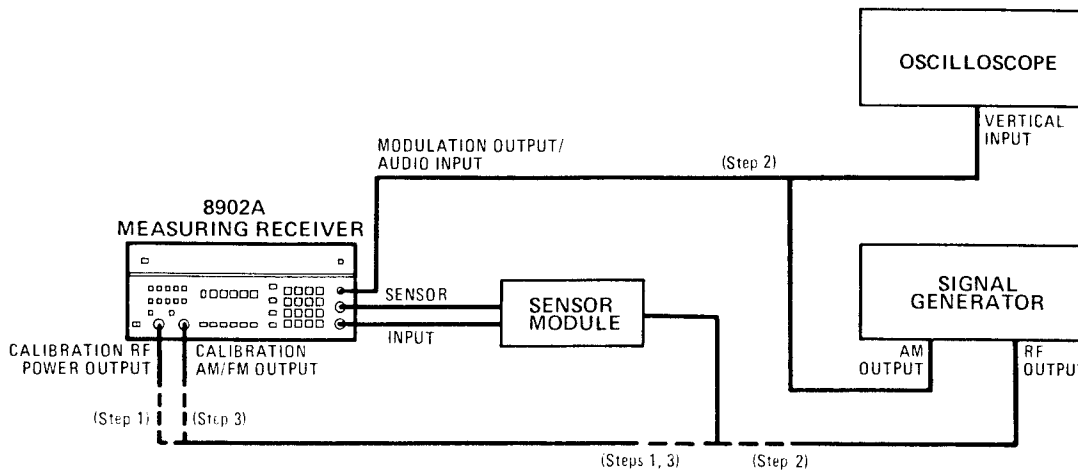

Figure 3-3. Basic Functional Checks Setup

Equipment

- Oscilloscope HP 1740A
- Signal Generator HP 8640B Options 001 and 002
- Sensor Module. HP 11722A

Procedure

Preliminary Check

1. Remove any cables from the Measuring Receiver's RF INPUT and SENSOR input connectors. Set POWER switch to STBY, then back to ON. Observe the front-panel LED annunciators, display segments and decimal points, and key lights. All LEDs should light for approximately 10 seconds at turn on and then all should momentarily turn off.
2. After the turn-on sequence, the instrument displays "--". The MHz annunciator, the FM annunciator under MODULATION OUTPUT, the AUTO TUNING annunciator (under the TRACK MODE key), and the FREQ key are lighted.

Ratio and Log/Lin (Cont'd)
(Includes the PREVIOUS RATIO key and Special Function 11.2)

Measurement Technique

When in the Ratio mode, measurements are made in the same way as when not in the Ratio mode; however, before the result is displayed, the internal controller converts it to ratio. The following equations are used for computing ratio:

$(M/R) (100\%) = \% \text{ ratio for all measurements,}$

$(20) \log (M/R) = \text{dB ratio for the following measurements}^1:$
AM, FM, ϕM , AUDIO DISTN, IF LEVEL, SINAD (29.0 SPCL), Ext Audio RMS Level.

$(10) \log (M/R) = \text{dB ratio for the following measurements}^2:$
FREQ, AUDIO FREQ, FREQ ERROR, LO Frequency (33.0 SPCL), IF Frequency (34.0 SPCL).

Comments

The SET REF key should be used when making tuned RF level ratio comparisons. (Refer to Attenuator Measurements).

When using dB ratio; any ratio reference or measurement result that causes the value of M/R (see equations above) to approach 0 causes the instrument to display Error 11.

The RATIO Keys are convenient when used to check modulation or RF level flatness throughout an RF frequency range (use Track Mode tuning described in RF Frequency Tuning) or throughout the audio range.

The reference that is kept for a ratio measurement can be entered as a limit reference (refer to Limit).

The following list provides some useful reference values for making ratio measurements:

- To display broadcast FM relative to 75 kHz, use 75 and % ratio.
- To display ϕM in degrees, use 1.745 and % ratio.
- To display AM as dB down from the carrier, use 200 and dB ratio.
- To display rms calibrated average as true average, use 111.07 and % ratio.
- To display rms calibrated average peak, use 70.7 and % ratio.

Related Functions

Error Message Summary

Limit

Special Functions

RF Frequency Tuning

OPERATOR'S CHECKS

3-10. Basic Functional Checks (Cont'd)**RF Power Calibration Check**

3. Connect the CALIBRATION RF POWER OUTPUT to the sensor module input. (Step 1 of Figure 3-3.)
4. Press the RF POWER key. The instrument displays Error 15 (unless calibration factors have already been entered).
5. If the instrument displays Error 15, enter the RF Power Calibration Factors that are printed on the bottom cover of the sensor module:
 - a. Enter the reference calibration factor by keying in 37.3 and pressing the SPCL key. Then key in the value of the reference calibration factor and press the Blue Key and % CAL FACTOR key (the MHz key).
 - b. Enter each frequency/calibration factor pair by first keying in the numeric code 37.3 and pressing the SPCL key. Next, key in the frequency value (in MHz), and press the MHz key. Then, key in the value of the calibration factor, and press the Blue Key and % CAL FACTOR key. Error 15 continues to be displayed until the Measuring Receiver is able to interpolate a frequency/calibration factor pair from those pairs entered. (For more information, refer to RF Power Calibration and RF Power Calibration Factors in the Detailed Operating Instructions in this section.)
6. Press the ZERO key. 0.0 is displayed briefly and then a value less than 0.003 mW is displayed.
7. Press the CALIBRATE key. When a value appears in the display, press the Blue Key and SAVE CAL key (the CALIBRATE key). The display shows 1.000 mW. Turn off the calibrator by pressing the CALIBRATE key again.

RF Power Check

8. Set the signal generator to 100 MHz CW at -10 dBm (as measured on its level meter).
9. Connect the RF output of the signal generator to the input of the sensor module, and MODULATION OUTPUT/AUDIO INPUT to the vertical input of the oscilloscope and to the AM output of the signal generator using a BNC tee. (Step 2 of Figure 3-3) (Note: The connection from the MODULATION OUTPUT/AUDIO INPUT to both the oscilloscope and the signal generator could cause a loading problem if the signal generator is not as suggested. Make these connections only when required if this is a problem.)

Ratio and Log/Lin (Cont'd)
 (Includes the PREVIOUS RATIO key and Special Function 11.2)

Procedures (cont'd)

3. Press the RATIO key. The display will show the measurement result relative to the reference value.



To use the Previous Ratio function:

1. Perform the procedure to select a ratio reference.
2. Select the desired Measurement mode. (The Measuring Receiver uses the same value as that entered in the Ratio mode regardless of the current measurement selected.)
3. Press the Blue Key and the PREVIOUS RATIO (RATIO) key. The display will show the measurement result relative to the original reference value.

To display the ratio (or previous ratio) reference, key in 11.2 SPCL.

Examples

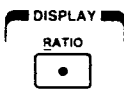
35.35 kHz FM deviation is displayed; to enter this value as the RATIO reference for future measurements:

<p>LOCAL (keystrokes)</p>	
 <p>(program codes)</p>	<p>R1 Display</p>

The result from this comparison is either 100% (if linear results are selected), or 0 dB (if logarithmic results are selected).

OPERATOR'S CHECKS

3-10. Basic Functional Checks (Cont'd)

10. Press the LOG/LIN key to display dBm. Read between -11.0 and -9.0 dBm on the display.

RF Peak Level Check

11. Key in the numeric code 35.0 and press the SPCL key. The Measuring Receiver displays between -16.00 and -6.00 dBm.

Frequency Check

12. Press the FREQ key. Key in 7.1 and press the SPCL key to set the RF Frequency Resolution to 10 Hz. Set the signal generator's frequency as shown in the following table. For each frequency, compare the signal generator's frequency display with the Measuring Receiver's display. The two displays should agree within the limits indicated.

Signal Generator Frequency (MHz)	Frequency Difference Limits (\pm Hz)
2	40
4	50
8	70
16	100
25	130
50	230
100	430
200	830
400	1600
800	3200

13. Set the signal generator frequency to 50 MHz. When the Measuring Receiver has tuned to the signal, press MHz, then S (shift) FREQ ERROR. The instrument displays between -2 and 2 kHz.
14. Key in 100, then press \uparrow kHz. The instrument displays between -102 and -98 kHz. Return the RF Frequency Resolution to automatic selection by keying 7.0 and pressing the SPCL key.

Track Mode Tuning Check

15. Press the AUTOMATIC OPERATION key and the FREQ key. Press the TRACK MODE key. Manually sweep the signal generator's frequency to 65 MHz; the Measuring Receiver's frequency display tracks the frequency as it changes. Press the TRACK MODE key again to turn off the function.

Ratio and Log/Lin (cont'd)
 (Includes the PREVIOUS RATIO key and Special Function 11.2)

Example (cont'd)

35.35 kHz FM deviation is displayed, to compare this to an FM deviation of 50 kHz:

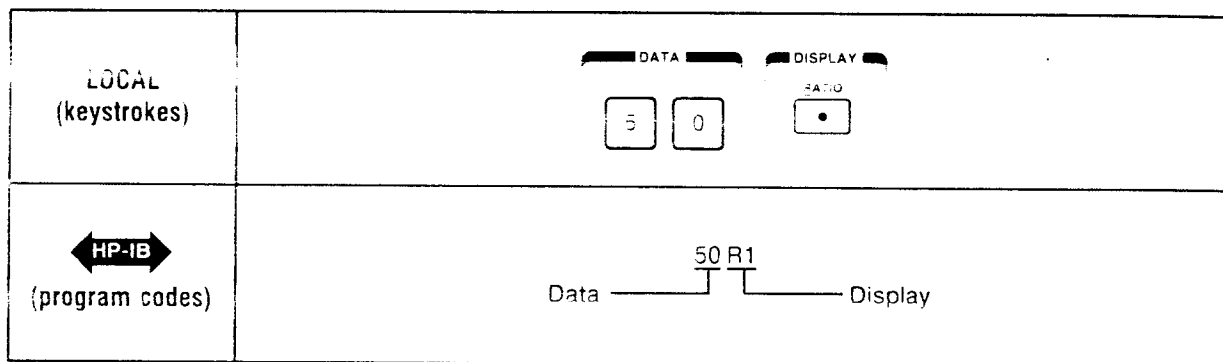

The result from this comparison is either 70.7% (if linear results are selected, or -3.01 dB (if logarithmic results are selected).

Program Codes

LOG display = LG
 LIN display = LN
 PREVIOUS RATIO = R2
 RATIO off = R0
 RATIO on = R1
 SPCL = SP

Indications

Display: When the LOG/LIN key is pressed, the displayed measurement changes to reflect the new value.

When the instrument is displaying a ratio or previous ratio comparison, the REL (relative) annunciator lights and the dB or % annunciator is displayed (as appropriate). The displayed value is the measurement result relative to the reference in % or dB.

When 11.2 SPCL is keyed, the last-entered ratio reference value is displayed.

Front Panel: When the instrument is displaying a ratio or previous ratio comparison, the RATIO key lights. The LEDs of all previously-selected annunciators remain on.

When Special Function 11.2 is selected, only the LED within the SPCL key lights.

OPERATOR'S CHECKS

3-10. Basic Functional Checks (Cont'd)**AM and FM Calibration Check**

16. Connect the CALIBRATION AM/FM OUTPUT to the input of the sensor module. (Step 3 of Figure 3-3.)
17. Press AM, then CALIBRATE. After a few seconds, the AM Calibration Factor is displayed. The displayed value is between 99.0 and 101.0%.
18. Press FM, then CALIBRATE. After a few seconds, the FM Calibration Factor is displayed. The displayed value is between 99.0 and 101.0%. Press the CALIBRATE key again to turn off that function.

AM Check

19. Reconnect the equipment as shown in Step 2 of Figure 3-3.
20. Press the Measuring Receiver's MHz key, and set the signal generator for 50% AM (as measured on its AM meter) at a 1 kHz rate.
21. Press AM. The Measuring Receiver displays between 46 and 54%.
22. Set the signal generator's AM to 25% (as measured on its AM meter). The Measuring Receiver displays between 22 and 28% with 0.01% resolution.

FM and Phase Modulation (ϕ M) Checks

23. Set the signal generator's AM off, and set FM to 50 kHz peak deviation (as measured on its FM meter) at a 1 kHz rate. Press FM. The Measuring Receiver displays between 45 and 55 kHz.
24. Adjust the signal generator's FM peak deviation for 50 kHz as displayed by the Measuring Receiver.
25. Press ϕ M. The instrument displays between 45 and 55 radians.

FM De-emphasis Check

26. Press FM. Press the RATIO key and set the LOG/LIN key to display %. The instrument displays between 99.8 and 100.2% REL.
27. The oscilloscope shows a sinusoidal waveform with a peak-to-peak amplitude between 0.9 and 1.1V and a period of 1 ms.

Ratio and Log/Lin

(Includes the PREVIOUS RATIO key and Special Function 11.2)

Description

The RATIO and PREVIOUS RATIO keys permit any measurement result to be compared to a reference value. The reference value may be the result of a previous measurement or a keyboard entry. Special Function 11.2 displays the current ratio reference.

The LOG/LIN key enables measurement results to be displayed linearly (%) or logarithmically (dB).

The ratio functions can be used with the following measurements:

AM	SINAD	(29.0 SPCL)
FM	Ext Audio RMS Level	(30.0 SPCL)
ϕM	LO Frequency	(33.0 SPCL)
RF POWER	IF Frequency	(34.0 SPCL)
FREQ	RF Level	(35.0 SPCL)
AUDIO FREQ		
AUDIO DISTN		
IF LEVEL		
TUNED RF LEVEL		
FREQ ERROR		

The Measuring Receiver keeps the current ratio reference as the previous ratio reference. A current ratio is changed to previous ratio status whenever the following conditions occur:

- the RATIO key is pressed a second time,
- a new measurement is selected, or
- the variable units selectable by the Data keys are changed.

The output signal at MODULATION OUTPUT/AUDIO INPUT is unaffected by the ratio functions.

Procedures

Use the LOG/LIN key anytime during the measurements to change the display to either dB or % (respectively).

To use the Ratio function:

1. Select the desired Measurement mode. Measurements possible with the ratio function are listed in "Description."
2. Set the display to the desired reference value:
 - Adjust the signal parameter being measured to a reference setting, or
 - enter the reference on the numeric keys. If the reference is to be negative value, press the Blue Key and the minus key (- key under the decimal point key).

 OPERATOR'S CHECKS

3-10. Basic Functional Checks (Cont'd)

28. Set FM DE-EMPHASIS to PRE-DISPLAY. Set FM DE-EMPHASIS time constant as listed in the following table. The Measuring Receiver displays a value within the limits listed. Also, the oscilloscope waveform changes proportionately to the display. (Allow for a x10 autorange at the output of MODULATION OUTPUT/AUDIO INPUT when FM DE-EMPHASIS is set to 750 us.)

FM De-Emphasis Time Constant (us)	Limits (% REL)	
	Minimum	Maximum
25	98.5	99.0
50	94.5	96.2
75	88.8	92.1
750	18.9	23.0

Audio Frequency and Audio Filters Check

29. Set FM DE-EMPHASIS off. Set the FM rate as listed in the following table. For each setting, perform the following steps:
- Set filters (HP or LP FILTER) to ALL OFF, and set RATIO off if it is on.
 - Press S (shift) AUDIO FREQ and set the signal generator's FM rate as listed in the table (as displayed on the Measuring Receiver).
 - Press FM and then press the RATIO key. Set LOG/LIN to dB to establish a reference of 0 dB.
 - Set the HP or LP FILTER as listed in the table, and fine adjust the FM rate for a reading of -3 dB REL.
 - Press S (shift) AUDIO FREQ and note the FM rate. The Measuring Receiver displays a rate within the limits listed.

Approximate FM Rate (Hz)	HP or LP Filter	Frequency Limits (Hz)	
		Minimum	Maximum
50	50 Hz HP	47.5	52.5
300	300 Hz HP	285	315
3 000	3 kHz LP	2 850	3 150
15 000	15 kHz LP	14 250	15 750
90 000	>20 kHz LP	80 000	140 000

Range Hold (Cont'd)

Indications

Display: When the RANGE HOLD key is pressed, the display returns to the measurement previously selected.

Front Panel: The light within the RANGE HOLD key lights. The light within the SPCL key also turns on.

Comments

Once settings are held with the Range Hold Function, one or more can be changed by manually entering the desired function. For example, the RANGE HOLD key places the instrument in the manual tune mode; press the Blue Key and AUTO TUNING (TRACK MODE) key to re-enter the automatic tuning mode.

Related Functions

Audio Range
Disable Error Message Control
Filters, RF and IF
RF Frequency Tuning
RF Input Attenuation and Gain
Special Functions

OPERATOR'S CHECKS

3-10. Basic Functional Checks (Cont'd)**Audio Distortion and SINAD Check**

30. Press the AM key and set filters to ALL OFF. Set the signal generator's FM off, and set the AM depth to 50% (as measured on the Measuring Receiver's display) at a 1 kHz rate. Press S (shift) and AUDIO DISTN. The displayed distortion is less than 3%.
31. Set the signal generator's AM for a 400 Hz rate. Press the Blue Key and 400 Hz DISTN key (PEAK- key). The displayed distortion is less than 3%.
32. Press the LOG/LIN key to display the distortion in dB. Key in 29.0 and press the SPCL key. The SINAD value is greater than 30 dB.

External Audio RMS Level

33. Press the AUDIO INPUT key. Set the signal generator's audio output level for 3 Vp-p (as read on the oscilloscope). Key in 30.0 and press the SPCL key. Set the LOG/LIN key to display volts. The Measuring Receiver's displayed level is between 0.95 and 1.17V.

Audio Detector Check

34. Press the FM key. Press the AUDIO INPUT key again to select the FM MODULATION OUTPUT. Set the signal generator's AM off and set the FM rate to 1 kHz. Press the RATIO key and set LOG/LIN to % to establish a reference of 100%. Set DETECTORS to PEAK-. The Measuring Receiver displays between 95 and 105% REL depending upon the signal generator's FM distortion.
35. Set DETECTOR to AVG. The instrument displays between 69.3 and 72.1% REL. Turn the ratio function off by pressing the RATIO key again.
36. Set DETECTOR to PEAK+ then press PEAK HOLD. Switch the signal generator's FM off. The Measuring Receiver display retains the largest value obtained after pressing PEAK HOLD. Turn off the peak hold function by pressing the PEAK+ key.

IF Level Check

37. Press S (shift) IF LEVEL and set the LOG/LIN key to display %. The Measuring Receiver displays between 99.9 and 100.1%.

Range Hold

Description

The RANGE HOLD key freezes the current ranges being used by the Measuring Receiver. This function, the corollary to the AUTOMATIC OPERATION key, disables the automatic tuning function and places Special Functions prefixed 1, 2, 3, 7, 9, and 10 in non-automatic modes. The following functions are not affected by the Range Hold function: HP and LP Filters, FM De-emphasis, Measurement, Detectors, and Display. Any Special Functions prefixed 1 through 10 that are already in manual modes also remain unaffected. The table below summarizes the effect of the Range Hold function:

Special Function Prefix	Measurement Function	Effect of RANGE HOLD on Functions
1	RF Input Attenuation and Gain	Holds setting
2	Audio Range	Holds setting
3	RF and IF Filters	Holds setting
4	Tuned RF Level Display Averaging	No effect
5	Audio Detector Response	No effect
6	AM ALC Response	No effect
7	RF Frequency Resolution	Holds setting
8	Error Message Disable	No effect
9	IF Gain	Holds setting
10	RF Power Range	Holds setting
	AUTO TUNING	Selects Manual Tuning

Procedures

To hold the special functions in a specific measurement state, set the Measuring Receiver as desired, then press the RANGE HOLD key.

To exit the Range Hold mode, press the RANGE HOLD key a second time or press the AUTOMATIC OPERATION key.

<=HP-IB=> Program Code

Automatic Ranging = G0
RANGE HOLD = G1

OPERATOR'S CHECKS

3-10. Basic Functional Checks (Cont'd)**IF Frequency and LO Frequency**

38. Set the signal generator to 100 MHz CW at 0 dBm. Press AUTOMATIC OPERATION, then key in 34.0 and press the SPCL key. The frequency displayed is between 1.45 and 1.55 MHz.
39. Key in 33.0 and press the SPCL key. The frequency displayed is between 101.45 and 101.55 MHz.
40. Key in 3.1 and press the SPCL key. The frequency displayed is between 100.4425 and 100.4575 MHz.

Peak Tuned RF Level and RF High-Pass Filter Check

41. Set the signal generator to 5.25 MHz CW at 0 dBm. Key in 36.0 and press the SPCL key and set the LOG/LIN key to display watts. The level displayed is between 0.0 and +6.0 mW.
42. Press the RATIO key and set the LOG/LIN key to dB, then key in 3.3 (to insert the RF high-pass filter) and press the SPCL key. The Measuring Receiver displays between -2 and -7 dB REL. Turn off the ratio function by pressing the RATIO key again. Key in 3.0 and press the SPCL key to return the RF high-pass and IF filter selection to automatic.

Synchronous and Average Tuned RF Level Check

43. Set the signal generator for 50 MHz CW at 0 dBm. Press S (shift) TUNED RF LEVEL and when the Measuring Receiver has tuned to the signal, press the MHz key. Press the CALIBRATE key. Set the signal generator so the Measuring Receiver displays 0.00 dBm.
44. Step down the level of the signal generator in 10 dB steps as listed in the following table. When the RECAL annunciator is displayed, press the CALIBRATE key while keeping the signal generator constant.

ϕM (Cont'd)
(Includes Special Function 2)

Comments

The PEAK+ detector always detects the carrier's positive, phase deviation while the PEAK- detector always detects the carrier's negative, phase deviation. The PEAK $\pm/2$ detector sums the positive and negative phase deviations and divides the total by two to provide an average peak value. (This value is not to be confused with a detected average value.)

The routine which automatically selects the modulation range contains regions of overlap between the following displayed peak deviations: 0.35 and .4 radians, 3.5 and 4 radians, and 35 and 40 radians. When using the average detector, ranging occurs with lower modulation levels displayed. If the modulation level is reduced from a higher range into an overlap region, the range may not change. To display the increased resolution, press the ϕM key a second time. To set the instrument to a selected modulation range, refer to Audio Range.

When operating above 2.5 MHz while using the 455 kHz IF, the upper limit of the modulation rate is that of the >20 kHz LP FILTER.

When operating with carrier frequencies below 2.5 MHz, the output signal at MODULATION OUTPUT/AUDIO INPUT is inverted unless using the 455 kHz IF.

AM conditions that cause the carrier signal to disappear will cause inaccuracies in the measurement of ϕM deviation, or they could cause Error 05 (FM squelched) to be displayed.

When ϕM is selected, the signal at the rear-panel FM OUTPUT still represents demodulated FM, not ϕM .

To display phase deviation in degrees instead of radians, enter 1.745 as a ratio reference and select the RATIO key. (Refer to Ratio.)

Pulsed phase modulation, such as phase shift keying, cannot be accurately demodulated or measured by the Measuring Receiver.

Related Functions

- Audio Detectors
- Audio Filters
- Audio Range
- Ratio
- Residual Noise Effects

 OPERATOR'S CHECKS

3-10. Basic Functional Checks (Cont'd)

Signal Generator's Output Level (dBm)	Display Limits (dBm)	
	Minimum	Maximum
-10	-10.06	-9.94
-20	-20.12	-19.88
-30	-30.27	-29.73
-40	-40.48	-39.52
-50	-50.75	-49.25
-60	-61.08	-58.92
-70	-71.68	-68.53
-80	-81.92	-78.08
-90	-92.43	-87.57
-100	-103.00	-97.00

45. Return the level of the signal generator to 0.00 dBm. Key in 4.4 and press the SPCL key. Press the CALIBRATE key. Set the signal generator so the Measuring Receiver displays 0.00 dBm.
46. Step down the level of the signal generator, in 10 dB steps, using the same measurement limits as in the previous table.

Error Check

47. Set the signal generator to 200 MHz CW at 0.00 dBm. On the Measuring Receiver, press AUTOMATIC OPERATION, then FM. Set DETECTOR to PEAK+. After the Measuring Receiver is tuned, press the RANGE HOLD key. Key in 100 then press \uparrow kHz. The Measuring Receiver displays Error 01. Press the RANGE HOLD key again to turn off the function.
48. Press \downarrow kHz. Key in 2.1 and press the SPCL key. Set the generator's FM on and adjust the peak deviation for 5 kHz (as read on its FM meter). The Measuring Receiver displays Error 04.
49. Key in 8.4 and press the SFCL key. The instrument displays Error 07.

ϕM (Cont'd)
(Includes Special Function 2)

HP-IB Program Code

All HP-IB codes for changing the limits of the phase modulation deviation are provided in "Procedures".

$\phi M = M3$

Indications

Display: When the ϕM key is pressed, the display shows the measured radian deviation on the carrier. The radian (rad) annunciator is displayed.

Front Panel: The LEDs within the keys representing the selected functions light.

Measurement Technique

The ϕM on the IF carrier is demodulated by a discriminator that produces a signal whose amplitude is proportional to the frequency deviation. The demodulated signal is filtered and passed through an integrator. The integrator's output is detected and displayed as phase deviation in radians. The integrator's output is made available at the output of MODULATION OUTPUT/AUDIO INPUT.

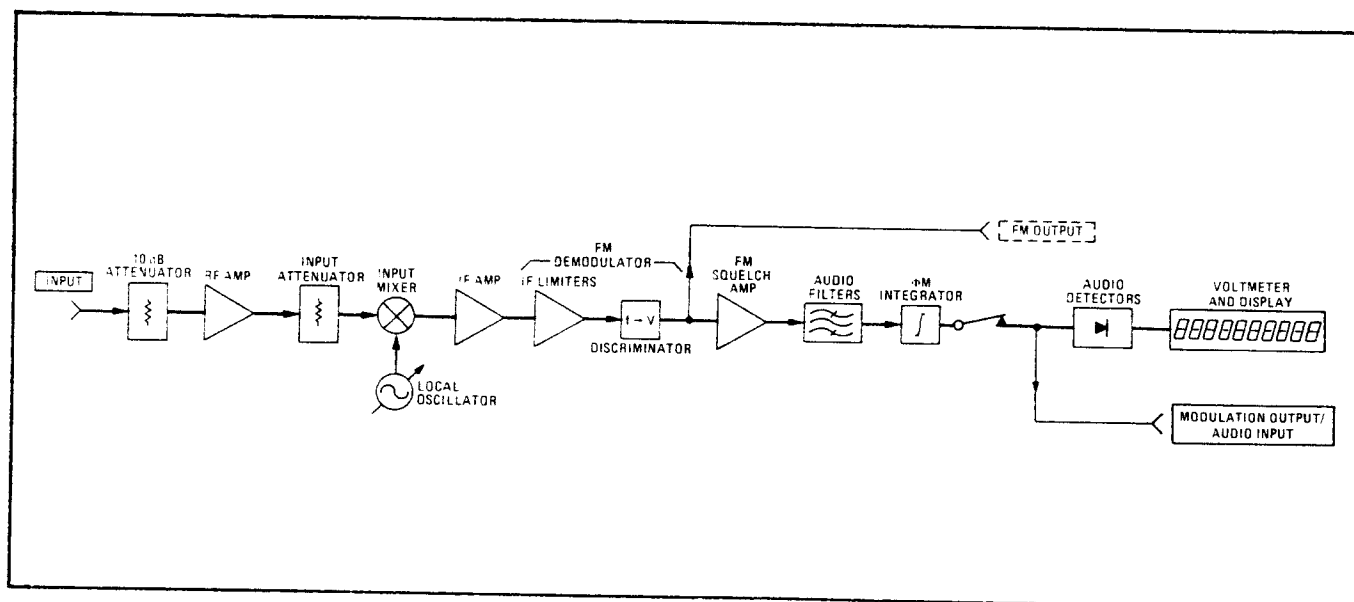

ϕM Measurement Block Diagram



OPERATOR'S CHECKS

3-11. HP-IB Functional Checks**DESCRIPTION:**

The following ten procedures check the Measuring Receiver's ability to process or send all of the applicable HP-IB messages described in paragraphs 3-12 through 3-31. In addition, the Measuring Receiver's ability to recognize its HP-IB address is checked and all of the bus data, handshake and control lines except DIO8 (the most significant data line which is not used by the Measuring Receiver) are set to both their true and false states. These procedures do not check whether or not all Measuring Receiver program codes are being properly interpreted and executed by the instrument; however, if the front panel operates as expected, the program codes, in all likelihood, will be correctly implemented.

The validity of these checks is based on the following assumptions:

- The Measuring Receiver performs properly when operated via the front-panel keys (that is, in local mode). This can be verified with the preceding Basic Functional Checks in paragraph 3-11.
- The bus controller properly executes HP-IB operations.
- The bus controller's HP-IB interface properly executes the HP-IB operations.

If the Measuring Receiver appears to fail any of these HP-IB checks, the validity of the above assumptions should be confirmed before attempting to service the instrument.

The select code of the controller's HP-IB interface is assumed to be 7. The address of the Measuring Receiver is assumed to be 14 (its address as set at the factory). This select code-address combination (that is, 714) is not necessary for these checks to be valid. However, the program lines presented here would have to be modified for any other combination.

These checks are intended to be as independent of each other as possible. Nevertheless, the first four checks should be performed in order before other checks are selected. Any special initialization or requirements for a check are described at its beginning.

INITIAL SETUP:

The test setup is the same for all of the checks. Connect the Measuring Receiver to the bus controller via the HP-IB interface. Do not connect any equipment to any of the Measuring Receiver's input connectors.

ϕ M (Cont'd)
(Includes Special Function 2)

Procedure (cont'd)

The following table lists the different measurement range limits that can be selected with Special Function 2:

Modulation Range (Peak = rad. dev.)	Detector Selected	Special Function Code	Program Code ↔ HP-IB ↔	Display Resolution (radians)	MODULATION OUTPUT Sensitivity (mVac/radian)
Automatic Selection		2.0 SPCL	2.0SP	Automatic Selection	
≤0.4	RMS	2.4 SPCL	2.4SP	0.0001	10
≤4	Pk, Avg	2.4 SPCL	2.4SP	0.001	1
≤4	Pk, Avg, RMS	2.1 SPCL	2.1SP	0.001	1
≤40	Pk, Avg, RMS	2.2 SPCL	2.2SP	0.01	0.1
≤400	Pk, Avg, RMS	2.3 SPCL	2.3SP	0.1	0.01

To filter the demodulated signal, press the appropriate filter keys.
(Refer to Audio Filters).

If ϕ M deviation is to be displayed relative to a reference, enter the value as a ratio reference using the RATIO key. (Refer to Ratio.)

Example

To measure the positive-peak ϕ M deviation of a signal in a 50 Hz to 15 kHz demodulated signal bandwidth:

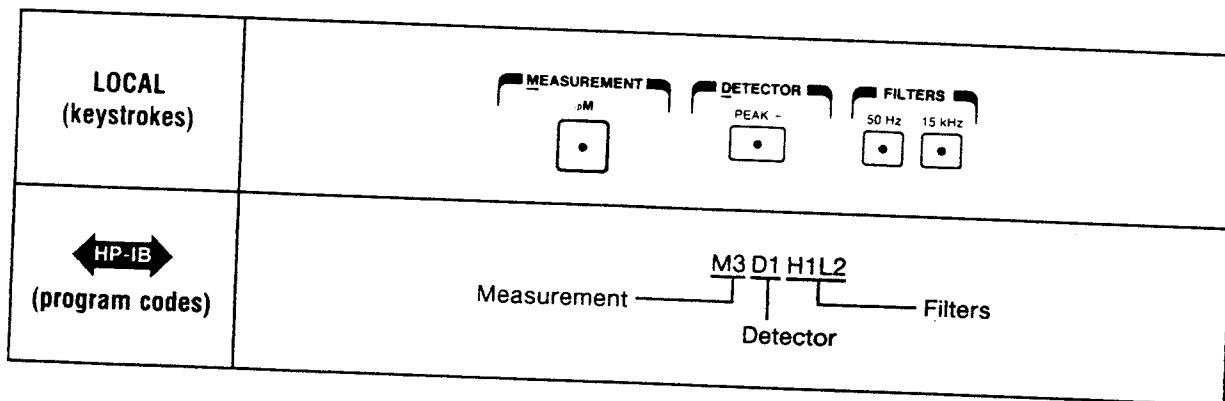



OPERATOR'S CHECKS

3-11. HP-IB Functional Checks (Cont'd)

EQUIPMENT:

HP-IB Controller....HP 9825A/98213A (General and Extended I/O ROM)
 --or-- HP 9835A/98332A (I/O ROM)
 --or-- HP 9845A (with HP-IB I/O capability)

HP-IB Interface.....HP 98034A (use "revised" version with 9835A and 9845A)

Address Recognition

NOTE:

This check determines whether or not the Measuring Receiver recognizes when it is being addressed and when it is not. This check assumes only that the Measuring Receiver can properly handshake on the bus. Before beginning this check, set the Measuring Receiver's POWER switch to STBY, then to ON.

Description	HP 9825A (HPL)	HP 9835A and 9845A (BASIC)
Set the Remote Enable (REN) bus control line false.	lcl 7	LOCAL 7
Send the Measuring Receiver's listen address.	wrt 714	OUTPUT 714

OPERATOR'S RESPONSE:

Check that the Measuring Receiver's LISTEN annunciator is on.

Unaddress the Measuring Receiver by sending a different address.	wrt 715	OUTPUT 715
--	---------	------------

OPERATOR'S RESPONSE:

Check that the Measuring Receiver's LISTEN annunciator is turned off.

ϕ M
(Includes Special Function 2)

Description

The ϕ M key enables the Measuring Receiver to measure the phase modulation deviation of the tuned input signal.

The demodulated ϕ M is present at MODULATION OUTPUT/AUDIO INPUT (unless AUDIO INPUT is selected).

The ϕ M measurement is specified only for carriers from 10 to 1300 MHz; however, ϕ M measurements can be performed on carriers from 150 kHz to 10 MHz. Higher frequencies can be measured when an external LO is used. (Refer to Frequency Offset Control). The ϕ M measurement is only specified for modulation rates from 200 Hz to 20 kHz; however, the low frequency 3 dB limit is typically 7 Hz.

The demodulated signal's frequency and distortion can also be characterized. (Refer to Audio Distortion and Level and to Audio Frequency.)

The following figure illustrates the display resolution for different combinations of peak phase deviation and modulation rate.

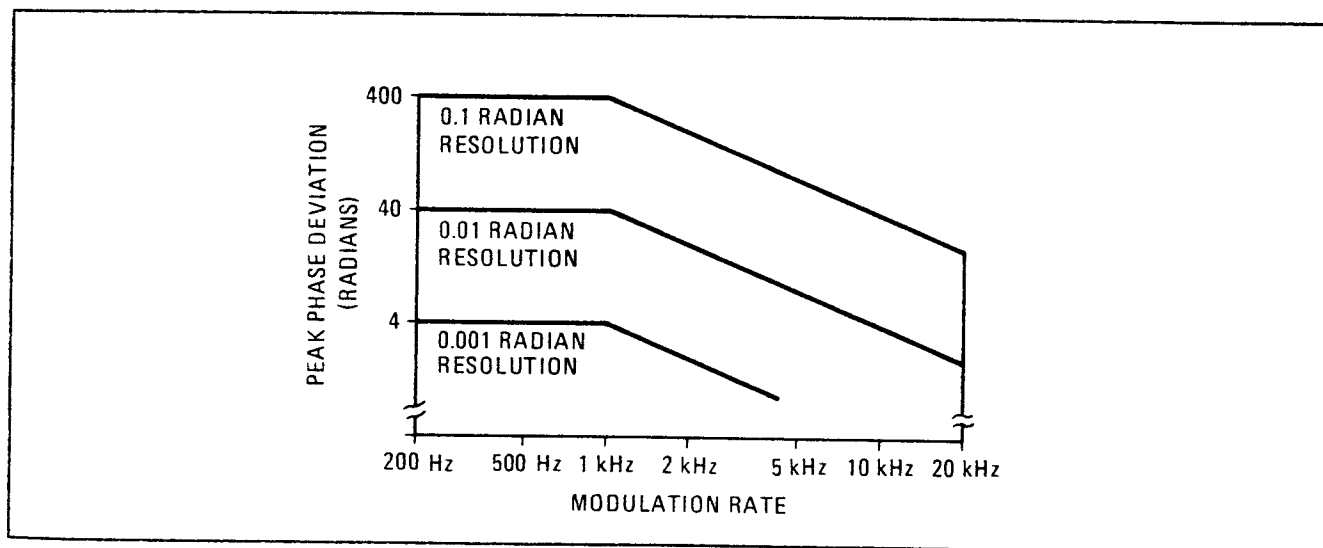

Procedure

To make a ϕ M measurement, first tune the instrument to the input signal. (Refer to RF Frequency Tuning or press AUTOMATIC OPERATION.)

Press the ϕ M key, and select an audio detector: PEAK+, PEAK-, or AVG. The RMS detector, selected by pressing the Blue Key and the RMS key, is not quite as accurate in measuring FM and is usually only used for audio distortion measurements. (Refer to Audio Distortion and Level and to Audio Detectors).



OPERATOR'S CHECKS

3-11. HP-IB Functional Checks (Cont'd)

Remote and Local Messages and the LOCAL Key

NOTE:

This check determines whether the Measuring Receiver properly switches from local to remote control, from remote to local control, and whether the LOCAL key returns the instrument to local control. This check assumes that the Measuring Receiver is able to both handshake and recognize its own address. Before beginning this check, set the Measuring Receiver's POWER switch to STBY, then to ON.

Description	HP 9825A (HPL)	HP 9835A and 9845A (BASIC)
Send the Remote Message (by setting Remote Enable, REN, true and addressing the Measuring Receiver to listen).	rem 714	REMOTE 714

OPERATOR'S RESPONSE:

Check that the Measuring Receiver's REMOTE and LISTEN annunciators are on.

Send the Local Message to the Measuring Receiver.	lcl 714	LOCAL 714
---	---------	-----------

OPERATOR'S RESPONSE:

Check that the Measuring Receiver's REMOTE annunciator is off but its LISTEN annunciator is on.

Send the Remote message to the Measuring Receiver.	rem 714	REMOTE 714
--	---------	------------

OPERATOR'S RESPONSE:

Check that the Measuring Receiver's REMOTE and LISTEN annunciators are on. Press the LOCAL key on the Measuring Receiver. Check that the Measuring Receiver's REMOTE annunciator is now off, but that its LISTEN annunciator remains on.

Peak Tuned RF Level (Cont'd)
(Special Function 36)

Indications (cont'd)

Display: notation; that is, the measured value is followed by a signed, power-of-ten multiplier. The following table shows the annunciator units for linear and logarithmic formats:

Linear Unit	Logarithmic Unit
W	dBm
V	dBV
mV	dB mV
μ V	dB μ V

Front Panel: The LED within the SPCL key lights.

Measurement Technique

When the Measuring Receiver is tuned, all the power falling within the IF bandpass filter is amplified and peak detected. The power is then measured by the voltmeter and displayed in the selected measurement units.

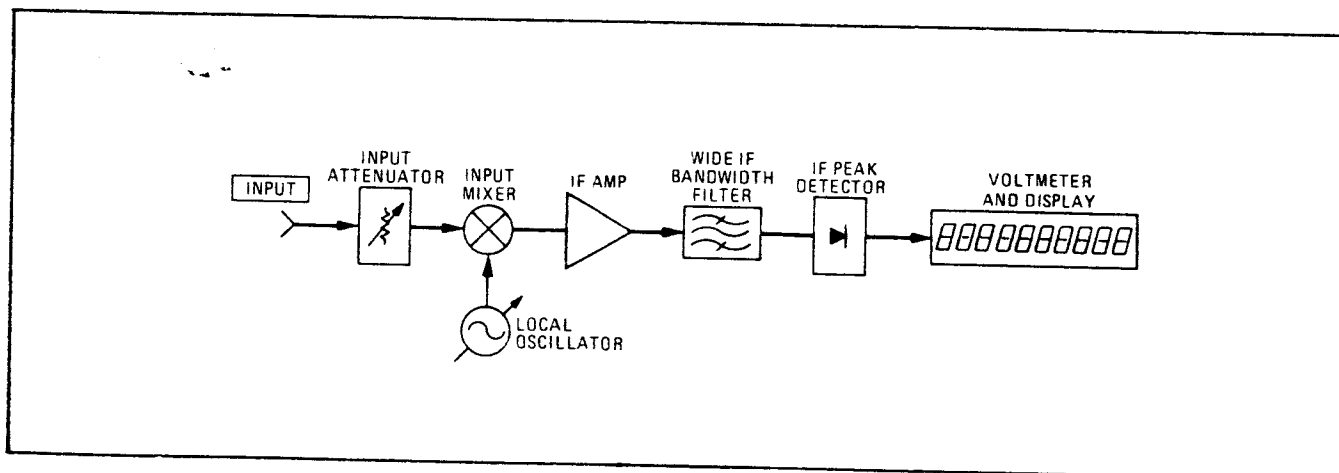

Peak Tuned RF Level Measurement Block Diagram

Comments

Use an external power sensor to make accurate, absolute power measurements. (Refer to RF Power or to Tuned RF Level.)

Related Functions

IF Level
RF Frequency Tuning

RF Power
Tuned RF Level



 OPERATOR'S CHECKS

3-11. HP-IB Functional Checks (Cont'd)

Sending the Data Message

NOTE:

This check determines whether or not the Measuring Receiver properly issues Data messages when addressed to talk. This check assumes that the Measuring Receiver is able to handshake and recognize its own address. Before beginning this check, set the Measuring Receiver's POWER switch to STBY, then to ON.

Description	HP 9825A (HPL)	HP 9835A and 9845A (BASIC)
Address the Measuring Receiver to talk and store its output data in variable V. (The output is Error 96 since there is no signal at its INPUT.)	red 714,V	ENTER 714;V
Display the value of V.	dsp V	PRINT V

OPERATOR'S RESPONSE:

Check that the Measuring Receiver's TALK annunciator is on. The controller's display should read 90000096000.00 (HP 9825A) or 90000096000 (HP 9835A and 9845A).

Receiving the Data Message

NOTE:

This check determines whether or not the Measuring Receiver properly receives Data messages. The Data messages sent also cause the 7 least significant HP-IB data lines to be placed in both their true and false states. This check assumes the Measuring Receiver is able to handshake, recognize its own address, and properly make the remote/local transitions. Before beginning this check, set the Measuring Receiver's POWER switch to STBY, then to ON.

Peak Tuned RF Level (Special Function 36)

Description

Special Function 36 enables the Measuring Receiver to measure the peak RF power falling within its tuned IF range. (See the block diagram in "Measurement Technique".) The Peak Tuned RF Level function is not calibrated, and so it is not as accurate or sensitive as the Tuned RF Level function (initiated with the TUNED RF LEVEL key) that can only be made at a single frequency. The Peak Tuned RF Level function enables the instrument to measure the level of frequencies that are drifting, or to determine flatness as a function of carrier frequency.

When the peak tuned RF level measurement is selected, MODULATION OUTPUT/AUDIO INPUT continues to output the demodulated signal corresponding to the last modulation type selected (unless AUDIO INPUT is selected). AM OUTPUT and FM OUTPUT (rear panel) remain active during this measurement.

Procedures

To make a peak tuned RF level measurement, first tune the instrument to the input signal. (Refer to RF Frequency Tuning or press AUTOMATIC OPERATION). Key 36.0, then press the SPCL key.

If peak tuned RF level is to be displayed relative to a reference, enter the value as a ratio reference using the RATIO key. (Refer to Ratio.)

Program Code

LIN results = LN
LOG results = LG
SPCL = SP
VOLTS units = VL

mV units = MV
uV units = UV
WATTS units = WT

Indications

Display: As the numeric code is entered, it appears on the display. When the SPCL key is pressed, the peak tuned RF level is displayed. When a measured value is displayed, the selected units annunciator lights, and if the units are linear, the display indicates the measurement in scientific



OPERATOR'S CHECKS

 3-11. HP-IB Functional Checks (Cont'd)
 Receiving the Data Message (Cont'd)

Description	HP 9825A (HPL)	HP 9835A and 9845A (BASIC)
Send the first part of the Remote message (enabling the Measuring Receiver to remote).	rem 7	REMOTE 7
Address the Measuring Receiver to listen (completing the Remote message), then send a Data message (manually tuning the Measuring Receiver to 1 MHz).	wrt 714, "1MZ"	OUTPUT 714, "IMZ"

OPERATOR'S RESPONSE:

Check that the Measuring Receiver's REMOTE and LISTEN annunciators are on. Check also that its 15 kHz LP FILTER key light is on and the AUTO TUNING light is off.

Local Lockout and Clear Lockout/Set Local Messages

NOTE:

This check determines whether or not the Measuring Receiver properly receives the Local Lockout message, disabling all front-panel keys. The check also determines whether or not the Clear Lockout/Set Local message is properly received and executed by the Measuring Receiver. This check assumes that the Measuring Receiver is able to handshake, recognize its own address, and properly make the remote/local transitions. Before beginning this check, set the Measuring Receiver's POWER switch to STBY, then to ON.

Modulation Output/Audio Input (Cont'd)
(Includes the AUDIO INPUT key)

Comments

Errors 01 through 03, 05, 10, and HP-IB Error 96 (corresponds to a display of two dashes) turn off the signal at MODULATION OUTPUT/AUDIO INPUT.

When the Measuring Receiver is first powered up, the demodulated signal at MODULATION OUTPUT/AUDIO INPUT is FM. The sensitivity is 0.01 mVac/Hz and will not autorange to more sensitive ranges. This is because at power up, FREQ is selected, and thus Error 04 (audio circuits overdriven) is automatically disabled. When Error 04 is disabled, only autoranging to less sensitive audio ranges is allowed.

When Error 01 through Error 04 are always enabled (8.8 SPCL), the signal at MODULATION OUTPUT/AUDIO INPUT is entirely safeguarded. Under this condition an error is displayed when the signal at MODULATION OUTPUT/AUDIO INPUT is uncalibrated. (Refer to Disable Error Message Control.)

Related Functions

AM
Audio Filters
Audio Range
Disable Error Message Control
FM
 ϕ M



 OPERATOR'S CHECKS

 3-11. HP-IB Functional Checks (Cont'd)
 Local Lockout and Clear Lockout/Set Local Messages (Cont'd)

Description	HP 9825A (HPL)	HP 9835A and 9845A (BASIC)
Send the first part of the Remote message (enabling the Measuring Receiver to remote).	rem 7	REMOTE 7
Send the Local Lockout message.	llo 7	LOCAL LOCKOUT 7
Address the Measuring Receiver to listen (completing the Remote message).	wrt 714	OUTPUT 714

OPERATOR'S RESPONSE:

Check that the Measuring Receiver's REMOTE and LISTEN annunciators are on. Press the Measuring Receiver's LOCAL key. Both its REMOTE and LISTEN annunciators remain on.

Send the Clear Lockout/Set Local message.	lcl 7	LOCAL 7
---	-------	---------

OPERATOR'S RESPONSE:

Check that the Measuring Receiver's REMOTE annunciator is off but its LISTEN annunciator remains on.

Clear Message

NOTE:

This check determines whether or not the Measuring Receiver properly responds to the Clear message. This check assumes that the Measuring Receiver is able to handshake, recognize its own address, make the remote/local changes, and receive Data messages. Before beginning this check set the Measuring Receiver's POWER switch to STBY, then to ON.

Modulation Output/Audio Input (Cont'd)
(Includes the AUDIO INPUT key)

Description (cont'd)

The level of the output signal at MODULATION OUTPUT/AUDIO INPUT autoranges; usually between 0 and 4 V_{peak} into an open circuit. The modulation type and the displayed resolution determine the sensitivity at the output (into an open circuit). The following table examines this relationship. (Refer to Audio Range for more information on modulation ranges.)

AM		FM		ϕM	
Display Resolution (%)	Modulation Output Sensitivity (Vac/%)	Display Resolution (Hz)	Modulation Output Sensitivity (mVac/Hz)	Display Resolution (radians)	Modulation Output Sensitivity (mVac/radian)
0.001	1	0.01*	100	0.0001	10
		0.1	10	0.001	1
0.01	0.1	1	1	0.01	0.1
		10	0.1	0.1	0.01
0.1	0.01	100	0.01	0.1	0.01

*Available only with 750 μs de-emphasis, pre-display.

Block Diagram

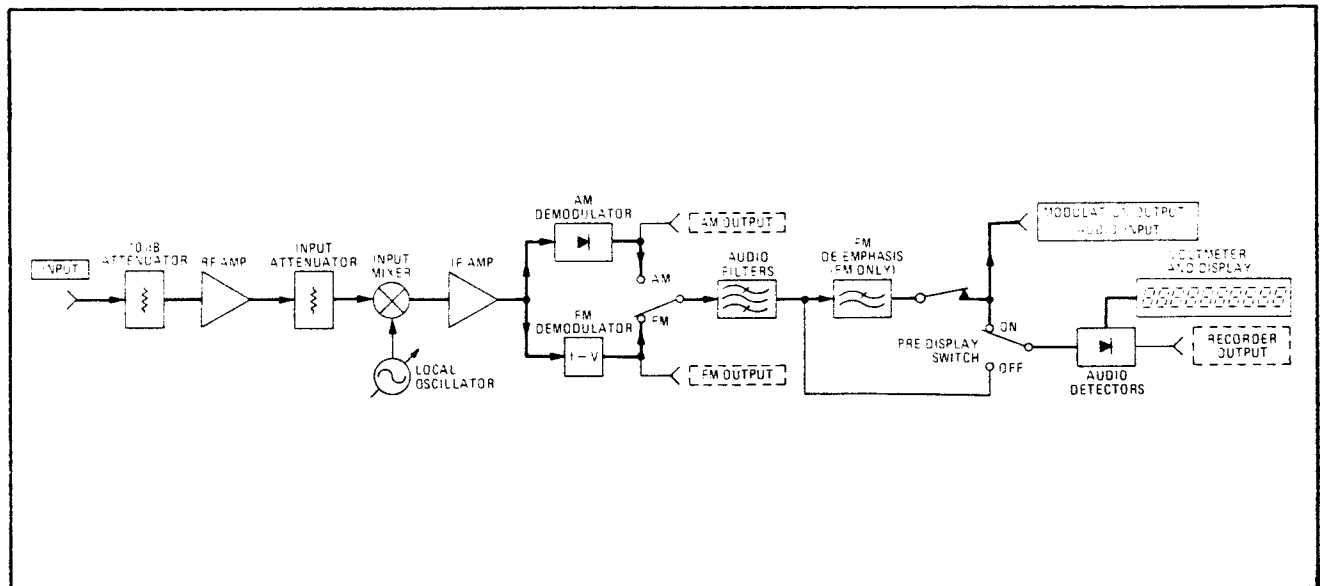

Modulation Output/Audio Input Block Diagram



OPERATOR'S CHECKS

3-11. HP-IB Functional Checks (Cont'd)
Clear Message (Cont'd)

Description	HP 9825A (HPL)	HP 9835A and 9845A (BASIC)
Send the first part of the Remote message (enabling the Measuring Receiver to remote).	rem 7	REMOTE 7
Address the Measuring Receiver to listen (completing the Remote message), then send a Data message that sets the Measuring Receiver's tuning to manual (lighting the SPCL light).	wrt 714, "MZ"	OUTPUT 714; "MZ"

OPERATOR'S RESPONSE:

Check that the Measuring Receiver's REMOTE and LISTEN annunciators are on and that the AUTO TUNING light is off.

Send the Clear message (setting the Measuring Receiver's tune mode back to automatic).	clr 714	RESET 714
--	---------	-----------

OPERATOR'S RESPONSE:

Check that the Measuring Receiver's REMOTE and LISTEN annunciators are on and that the AUTO TUNING light is on.

Abort Message

NOTE:

This check determines whether or not the Measuring Receiver becomes unaddressed when it receives the Abort message. This check assumes that the Measuring Receiver is able to handshake, recognize its own address, make the remote/local changes, and enter serial-poll mode. Before beginning this check, set the Measuring Receiver's POWER switch to STBY, then to ON.

Modulation Output/Audio Input (Cont'd)
(Includes the AUDIO INPUT key)

Description (cont'd)

Many measurements have a direct effect on MODULATION OUTPUT/AUDIO INPUT. The following table lists the Measuring Receiver's response when the listed measurement functions are initiated (any measurement not listed do not have an effect):

Measurement	Measuring Receiver's Response
AM	Selects the demodulated AM signal (unless AUDIO INPUT is selected).
AUDIO DISTN	Measures signal available at MODULATION OUTPUT/AUDIO INPUT (depends on AUDIO INPUT key selection).
AUDIO FREQ	Measures signal available at MODULATION OUTPUT/AUDIO INPUT (depends on AUDIO INPUT key selection).
AUTOMATIC OPERATION	Selects the last-selected modulation measurement.
FM	Selects the demodulated FM signal (unless AUDIO INPUT is selected).
FREQ	Selects the last-selected modulation measurement.
FREQ ERROR -	Selects the last-selected modulation measurement.
INSTR PRESET	Refer to Instrument Preset
ϕ M	Selects the demodulated FM signal (unless AUDIO INPUT is selected).
RF POWER	Blanks output; turns off all Modulation Output, Audio Input keylights.
TUNED RF LEVEL	Blanks output; turns off all Modulation Output, Audio Input keylights.
29.0 SPCL (SINAD)	Selects the last-selected modulation measurement.
30.0 SPCL (Ext. Audio RMS Level)	Selects AUDIO INPUT.
33.0 SPCL (LO Frequency)	Selects the last-selected modulation measurement.
34.0 SPCL (IF Frequency)	Selects the last-selected modulation measurement.
35.0 SPCL (RF Level)	Blanks output; turns off all Modulation Output, Audio Input keylights.
36.0 SPCL (Peak Tuned RF Level)	Blanks output; turns off all Modulation Output, Audio Input keylights.
HP and LP Filters, and FM De-emphasis affect the output, but not the input of MODULATION OUTPUT/AUDIO INPUT. (See the Modulation Output/Audio Input Block Diagram in this instruction.)	



 OPERATOR'S CHECKS

 3-11. HP-IB Functional Checks (Cont'd)
 Abort Message (Cont'd)

Description	HP 9825A (HPL)	HP 9835A and 9845A (BASIC)
Send the Remote message to the Measuring Receiver.	rem 714	REMOTE 714

OPERATOR'S RESPONSE:

Check that the Measuring Receiver's REMOTE and LISTEN annunciators are on.

Send the Abort message, unaddressing the Measuring Receiver.	cli 7	ABORTIO 7
--	-------	-----------

OPERATOR'S RESPONSE:

Check that the Measuring Receiver's LISTEN annunciator is off. Note that the HP 9835A and 9845A ABORTIO statement sends both the Abort message and the Local message. Thus, if the HP 9825A is being used, the Measuring Receiver's REMOTE annunciator should remain on. If the HP 9835A or 9845A is being used, the Measuring Receiver's REMOTE annunciator should turn off.

Send the Local message (HP 9825A only).	lcl 7	(The local message was already sent with the ABORTIO 7 statement above.)
Address the Measuring Receiver to talk and store its output data in variable V.	red 714,V	ENTER 714;V

OPERATOR'S RESPONSE:

Check that the Measuring Receiver's LISTEN annunciator is off but that its TALK annunciator is on.

Modulation Output/Audio Input
(Includes the AUDIO INPUT key)

CAUTION

Do not apply greater than 10 Vdc or greater than +30 dBm (1 watt) into MODULATION OUTPUT/AUDIO INPUT or damage to the instrument may result.

NOTE

For optimum signal flatness, cables attached to MODULATION OUTPUT/AUDIO INPUT should be terminated with their characteristic impedance.

Description

The output at MODULATION OUTPUT/AUDIO INPUT provides a calibrated output for signals demodulated by the Measuring Receiver. The output signal available at the connector usually corresponds to the current modulation measurement. The dc-coupled output has a 600 ohm output impedance at the BNC female connector.

The input at MODULATION OUTPUT/AUDIO INPUT provides external access to the audio measurement circuits. The input has a 100 kohm input impedance at the connector.

 OPERATOR'S CHECKS

 3-11. HP-IB Functional Checks (Cont'd)
 Abort Message (Cont'd)

Description	HP 9825A (HPL)	HP 9835A and 9845A (BASIC)
Send the Abort message, unaddressing the Measuring Receiver to talk.	cli 7	ABORTIO 7

OPERATOR'S RESPONSE:

Check that all the Measuring Receiver's HP-IB annunciators are off.

Send the serial-poll-enable bus command (SPE) through the interface to place the Measuring Receiver in serial-poll mode.	wti 0,7; wti 6,24	SENBUS 714; 1,24
--	----------------------	---------------------

OPERATOR'S RESPONSE:

On the Measuring Receiver, key in 61.3 and then press the SPCL key. The display should show 1.0. This indicates the Measuring Receiver is in serial-poll mode (indicated by the "1").

Send the Abort message, removing the Measuring Receiver from serial-poll mode.	cli 7	ABORTIO 7
--	-------	-----------

OPERATOR'S RESPONSE:

Check that the Measuring Receiver's display shows 0.0. This indicates the Measuring Receiver properly left serial-poll mode upon receiving the Abort message.

Status Byte Message

NOTE:

This check determines whether or not the Measuring Receiver sends the Status Byte message in both the local and remote modes. This check assumes that the Measuring Receiver is able to handshake, recognize its own address, and make the remote/local changes. Before beginning this check, set the Measuring Receiver's POWER switch to STBY, then to ON.

LO Input and LO Output (Cont'd) (Option 003)

Procedure

To use LO OUTPUT as a signal source:

1. Select an IF frequency of either 1.5 MHz or 455 kHz using Special Function 3. (If the IF frequency is not specified, the Measuring Receiver will assume the 1.5 MHz IF for keyboard-entered frequencies greater than 10 MHz and the 455 kHz IF for frequencies less than 10 MHz but greater than 2.5 MHz.)
2. Subtract the IF frequency from the frequency desired at LO OUTPUT, and enter the result, in MHz, via the numeric keys; then press the MHz key. (To tune the LO below 2.96 MHz, use the procedure as described, but select the 455 kHz IF using Special Function code 3.1, and disable Error 01 using Special Function code 8.1.)

To use LO INPUT to apply an external LO:

1. Select an IF frequency (1.5 MHz or 455 kHz) using Special Function 3.
2. Press the MHz key to enter manual tune mode (to prevent the internal LO from continuously tuning).
3. Add the IF frequency to the frequency to which the Measuring Receiver is to be tuned, and set the external LO to that frequency.
4. Adjust the external LO to 0 dBm and apply the signal to LO INPUT.

Comments

To tune to inputs below 2.5 MHz with an external LO, select the 1.5 MHz IF, but set the LO to approximately 100 MHz. The LO must be present to bias the Input Mixer on, but down-conversion of the RF input signal is unnecessary.

When an external LO is used, measurements made using the FREQ or FREQ ERROR keys are not accurate. To determine input frequency, subtract the IF frequency (Special Function 34) from the LO frequency used.

When using an external LO, rapid changes in LO frequency within the IF passband cause FM transients. Several seconds are then required before accurate measurements are possible. To avoid the problem, turn off the external LO when switching its frequency.

Related Functions

Disable Error Message Summary
Filters, RF and IF
IF Frequency

LO Frequency
RF Frequency Tuning



 OPERATOR'S CHECKS

 3-11. HP-IB Functional Checks (Cont'd)
 Status Byte Message (Cont'd)

Description	HP 9825A (HPL)	HP 9835A and 9845A (BASIC)
Place the Measuring Receiver in serial-poll mode and address it to talk (causing it to send the Status Byte message).	rds(714) □V	STATUS 714;V
Display the value of V.	dsp V	PRINT V

OPERATOR'S RESPONSE:

Depending on the vintage of the HP-IB interface (HP 98034A) used, the Measuring Receiver's TALK annunciator may be either on or off. The controller's display should read 0.00 (HP 9825A) or 0 (HP 9835A and HP 9845A).

Send the Remote message.	rem 714	REMOTE 714
Place the Measuring Receiver in serial-poll mode and address it to talk (causing it to send the Status Byte message).	rds(714) □V	STATUS 714;V
Display the value of V.	dsp V	PRINT V

OPERATOR'S RESPONSE:

Check that the Measuring Receiver's REMOTE annunciator is on. Depending upon the vintage of the HP-IB interface (HP 98034A) used, the Measuring Receiver's TALK annunciator may be either on or off. The controller's display should read 0.00 (HP 9852A) or 0 (HP 9835A and HP 9845A).

Require Service Message

NOTE:

This check determines whether or not the Measuring Receiver can issue the Require Service message (set the SRQ bus control line true). This check assumes that the Measuring Receiver is able to handshake, recognize its own address, make the remote/local changes, and receive Data messages. Before beginning this check, set the Measuring Receiver's POWER switch to STBY, then to ON.

LO Input and LO Output
(Option 003)

CAUTION

Do not apply greater than 40 Vdc or +5 dBm of RF power into the LO INPUT, or damage to the instrument may result. Do not apply dc voltage or RF power into the LO OUTPUT, or damage to the instrument may result.

Description

In Measuring Receivers with Option 003, the internal local oscillator signal (LO) passes through the rear-panel LO OUTPUT and LO INPUT connectors. The range of the LO signal is 1.27 MHz to 1301.5 MHz, at approximately 0 dBm. Both connectors are 50 ohm, ac-coupled, female, Type-N connectors.

NOTE

The rear-panel LO OUTPUT must be connected to the rear-panel LO INPUT for normal Measuring Receiver operation using the internal local oscillator.

Block Diagram

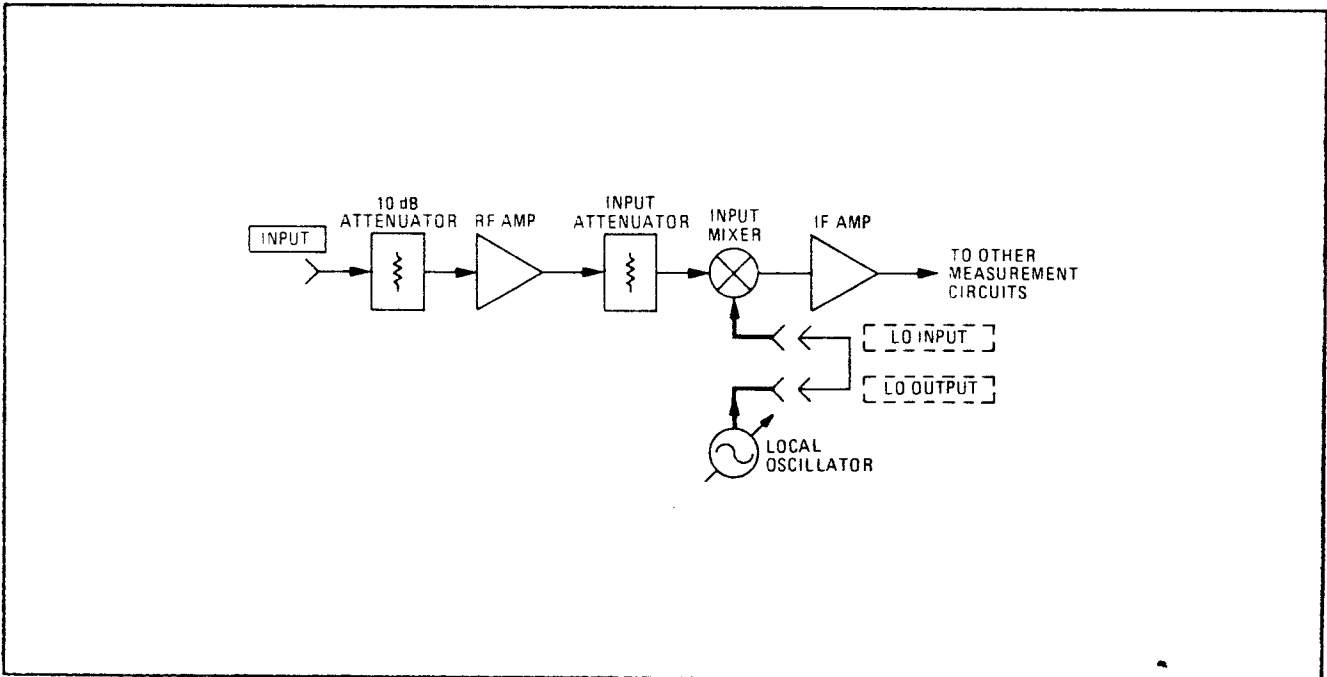

LO Input and LO Output Block Diagram



OPERATOR'S CHECKS

3-11. HP-IB Functional Checks (Cont'd)
Require Service Message (Cont'd)

Description	HP 9825A (HPL)	HP 9835A and 9845A (BASIC)
Send the first part of the Remote message (enabling the Measuring Receiver to remote).	rem 7	REMOTE 7
Address the Measuring Receiver to listen (completing the Remote message) then send a Data message (enabling a Require Service to be sent upon Instrument Error).	wrt 714, "22.4SP"	OUTPUT 714, "22.4SP"
Make the controller wait 2 seconds to allow time for the Measuring Receiver message. (This step is not necessary if sufficient time is allowed.)	wait 2000	WAIT 2000
Read the binary status of the controller's HP-IB interface and store the data in variable V (in this step, 7 is the interface's select code).	rds(7) □ V	STATUS 7;V
Display the value of the SRQ bit (in this step, 7 is the SRQ bit, numbered from 0).	dsp"SRQ=", bit (7,V)	PRINT "SRQ="; BIT (V,7)

OPERATOR'S RESPONSE:

Check that the Measuring Receiver's REMOTE, LISTEN, and SRQ annunciators are on and that the controller's display reads an SRQ value of 1, indicating the Measuring Receiver issued the Require Service message.

LO Frequency (Cont'd) (Special Function 33.0)

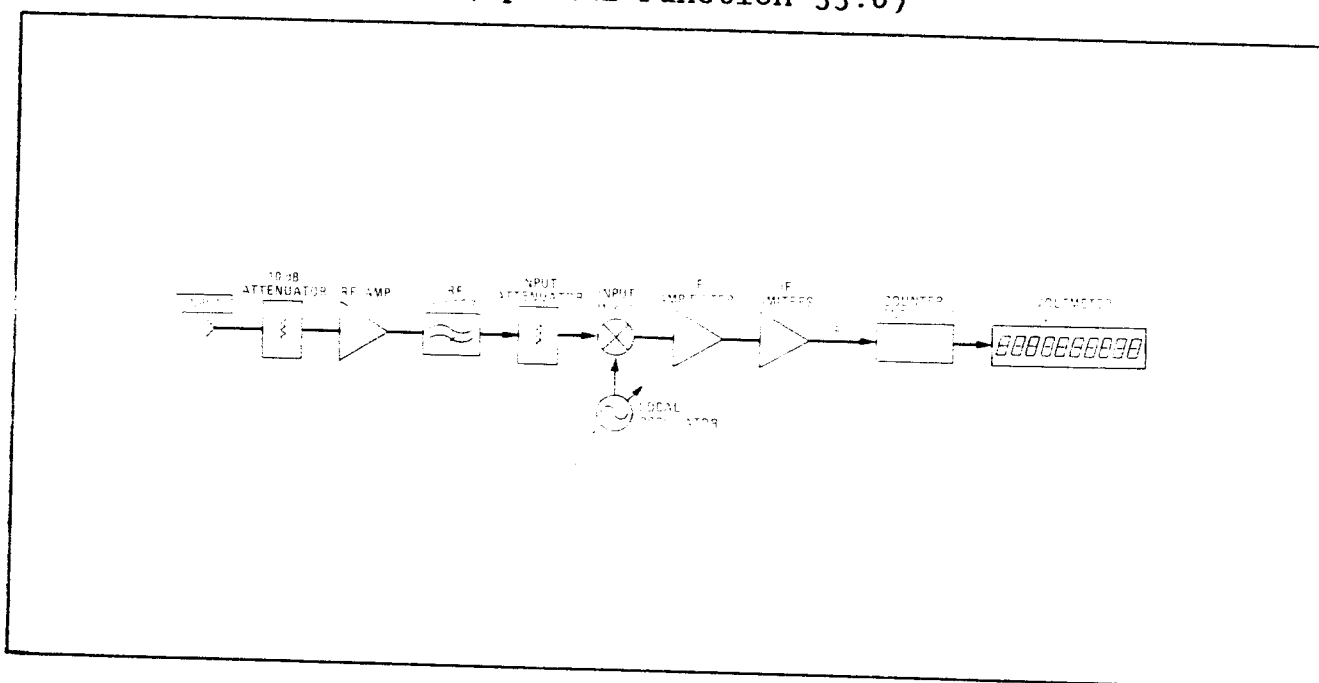

LO Frequency Measurement Block Diagram

Comments

Normally, the counter updates the display five times each second. For selection of other resolutions, refer to RF Frequency Resolution. (Note that counter accuracy is the reference accuracy ± 3 counts.)

When the RF input signal is less than 2.5 MHz, the LO frequency is set to 101.5 MHz.

Related Functions

LO Frequency
RF Frequency Resolution
RF Input Frequency
Special Functions



 OPERATOR'S CHECKS

3-11. HP-IB Functional Checks (Cont'd)

Trigger Message and Clear Key Triggering

NOTE:

This check determines whether or not the Measuring Receiver responds to the Trigger message and whether the CLEAR key serves as a manual trigger in remote. This check assumes that the Measuring Receiver is able to handshake, recognize its own address, make the remote/local changes, and send and receive Data messages. Before beginning this check, set the Measuring Receiver's POWER switch to STBY, then to ON.

Description	HP 9825A (HPL)	HP 9835A and 9845A (BASIC)
Send the first part of the Remote message (enabling the Measuring Receiver to remote).	rem 7	REMOTE 7
Address the Measuring Receiver to listen (completing the Remote message), then send a Data message (placing the Measuring Receiver in Hold mode).	wrt 714, "T1"	OUTPUT 714;"T1"
Send the Trigger message.	trg 7	TRIGGER 7
Address the Measuring Receiver to talk and store the data in variable V.	red 714,V	ENTER 714;V
Display the value of V.	dsp V	PRINT V

OPERATOR'S RESPONSE:

Check that both the Measuring Receiver's REMOTE and TALK annunciators are on. The controller's display should read 90000096000.00 (HP 9825A) or 90000096000 (HP 9835A and HP 9845A).

Address the Measuring Receiver to talk and store the data in variable V.	red 714,V	ENTER 714;V
--	-----------	-------------

LO Frequency (Special Function 33.0)

Description

Using the numeric keyboard and the SPCL key, the Measuring Receiver can be set to display the local oscillator (LO) frequency.

When the instrument is measuring the LO frequency, the signal at MODULATION OUTPUT/AUDIO INPUT remains unchanged.

Procedures

To measure the LO frequency, enter the numeric code 33.0, then press the SPCL key.

If the LO frequency is to be displayed relative to a reference, enter the value as a ratio reference using the RATIO key. (Refer to Ratio.)

HP-IB Program Codes

LO FREQUENCY = 33.0
SPCL = SP

Indications

Display: As the numeric code is entered, it appears on the display. When the SPCL key is pressed, the LO frequency is displayed (in MHz). The MHz annunciator is also displayed.

Front Panel: All measurement key lights turn off, the LED within the SPCL key lights.

Measurement Technique

The LO signal is a combination of the RF input signal and the intermediate frequency (IF). The Measuring Receiver counts the frequency of both the IF and the LO, and calculates their difference to determine the frequency of the RF input signal. RF input frequencies greater than 2.5 MHz are mixed with the LO to obtain either a 455 kHz or the 1.5 MHz IF. For RF input frequencies less than 2.5 MHz, although no down-conversion is necessary and the RF input signal is passed directly into the IF, the LO is tuned to 101.5 MHz to turn on the input mixer diodes.



OPERATOR'S CHECKS

3-11. HP-IB Functional Checks (Cont'd)
Trigger Message and Clear Key Triggering (Cont'd)

OPERATOR'S RESPONSE:

Check that the controller's "run" indicator is still on indicating that it has not received data from the Measuring Receiver. Press the Measuring Receiver's CLEAR key. The controller's "run" indicator should turn off.

Limit (Cont'd)
(Special Function 14)

Indications (cont'd)

Front Panel: The LED within the RATIO key lights when pressed; when pressed again, the LED is turned off.

When limits are cleared, set, or restored, the LED within the SPCL key does not light (Special Functions 14.0 through 14.4). When limits are displayed, or when the measurement code or the limit status is displayed, the LED within the SPCL key lights until the display times out (Special Functions 14.5 through 14.9).

Comments

The test for out-of-limit results is performed on the actual measurement results, not upon the displayed number. Thus, although the display shows a relative measurement result (that is, using the ratio functions) the limit test is still made upon the result before the ratio is computed. Limits cannot be set in terms of relative measurement results.

If Special Function 14.1 or 14.2 is initiated with no previous numeric value, the ratio reference becomes the entered value. The desired limit must be entered before the Special Function numeric code.

Related Sections

Ratio
Service Request Condition
Special Functions



3-12. REMOTE OPERATION HEWLETT-PACKARD INTERFACE BUS

The Measuring Receiver can be operated through the Hewlett-Packard Interface Bus (HP-IB). Bus compatibility, programming and data formats are described in the following paragraphs.

Except for the POWER switch and the Controller Reset Service Special Function, all Measuring Receiver operations (including service related functions) are fully programmable via HP-IB.

A quick test of the HP-IB I/O is described under Remote Operator's Checks (paragraph 3-11). These checks verify that the Measuring Receiver can respond to or send each of the applicable bus messages described in the following paragraphs.

For more information about HP-IB, refer to IEEE Standard 488, ANSI Standard MC1.1, the Hewlett-Packard Electronic Systems and Instruments catalog, and the booklet, "Improving Measurements in Engineering and Manufacturing" (HP part number 5952-0058).

3-13. HP-IB Compatibility

The Measuring Receiver's complete bus compatibility as defined in IEEE Standard 488, and the identical ANSI Standard MC1.1 is: SH1, AH1, T5, TE0, L3, LE0, SR1, RL1, PP0, DC1, DT1, C0.

3-14. Remote Mode

Remote Capability. In remote, most of the Measuring Receiver's front-panel controls are disabled (exceptions are the LOCAL and CLEAR keys). However, front-panel displays and the output signal at MODULATION OUTPUT/AUDIO INPUT remain active and valid. In remote, the Measuring Receiver can be addressed to talk or listen. When addressed to listen, the Measuring Receiver will respond to the Data, Trigger, Clear (SDC), and Local messages. When addressed to talk, the Measuring Receiver can issue the Data and Status Byte messages. Whether addressed or not, the Measuring Receiver will respond to the Clear (DCL), Local Lockout, Clear Lockout/Set Local, and Abort messages, and in addition, the Measuring Receiver can issue the Require Service message.

Local-to-Remote Mode Changes. The Measuring Receiver switches to remote operation upon receipt of the Remote message. The Remote message has two parts. They are:

- Remote enable bus control line (REN) set true
- Device listen address received once (while REN is true).

When the Measuring Receiver switches to remote, the REMOTE and either the TALK or LISTEN annunciators on its front panel will turn on.

Limit (Cont'd)
(Special Function 14)

Example

To set an upper limit of 75 kHz FM deviation:

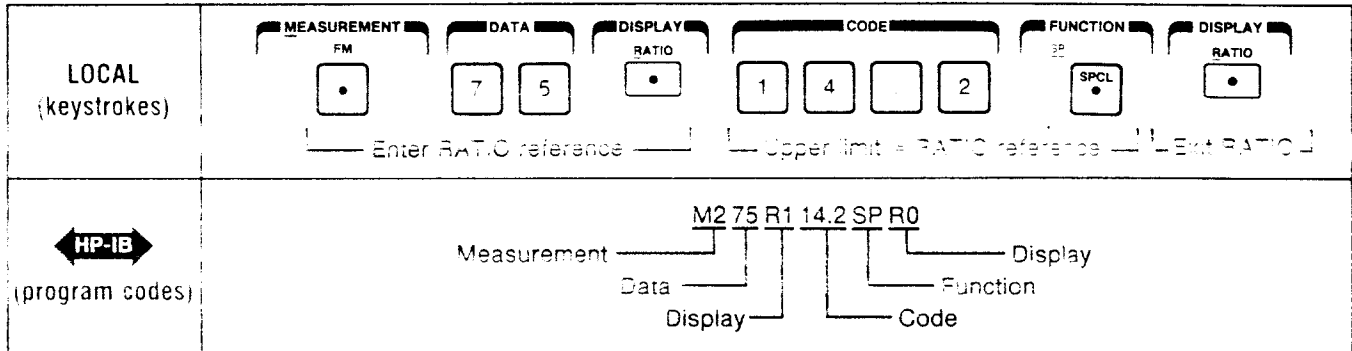

Read the FM deviation in kHz with an upper limit set at 75 kHz.

Program Codes

The codes for performing the various limit operations are provided in "Procedures".

RATIO off = R0
RATIO on = R1

Indications

If the Measuring Receiver is set to issue a service request when an out-of-limit measurement occurs, the service request may be cleared by serial polling.

Display: When the RATIO key is pressed, the value displayed is a reference value that is compared to the ratio reference entered. When the RATIO key is pressed a second time, the display returns to the previous measurement with the Limit function enabled.

When numeric codes 14.0 through 14.4 are keyed in, they appear on the display. When the SPCL key is pressed, the display returns to the measurement previously selected.

When numeric codes 14.5 through 14.9 are keyed in, they appear on the display. When the SPCL key is pressed, the requested action is displayed.

If a measurement falls out of set limits, the LIMIT annunciator is displayed. After the measurement returns to within the set limits, the LIMIT annunciator continues to be displayed until five successive measurements are made that fall within the set limits.

3-15. Local Mode

Local Capability. In local, the Measuring Receiver's front-panel controls are fully operational and the instrument will respond to the Remote message. Whether addressed or not, it will also respond to the Clear, Local Lockout, Clear Lockout/Set Local, and the Abort messages. When addressed to talk, the instrument can issue Data messages and the Status Byte message, and whether addressed or not, it can issue the Require Service message.

Remote-to-Local Mode Changes. The Measuring Receiver always switches to local from remote whenever it receives the Local message (GTL) or the Clear Lockout/Set Local message. (The Clear Lockout/Set Local message sets the Remote Enable control line [REN] false.) If it is not in Local Lockout mode, the Measuring Receiver switches to local from remote whenever its front-panel LOCAL key is pressed.

3-16. Addressing

The Measuring Receiver interprets the byte on the bus' eight data lines as an address or a bus command if the bus is in the command mode: attention control line (ATN) true and interface clear control line (IFC) false. Whenever the Measuring Receiver is being addressed to listen (whether in local or remote), the LISTEN annunciator on the front panel will turn on. When the Measuring Receiver is being addressed to talk, the TALK annunciator will turn on.

The Measuring Receiver's talk and listen addresses are switch selectable as described in paragraph 2-7. Refer to Table 2-2 for a comprehensive listing of all valid HP-IB address codes. To determine the present address setting, refer to the discussion "HP-IB Address" in the Detailed Operating Instructions in this section.

Local Lockout. When a data transmission is interrupted, which can happen by returning the Measuring Receiver to local mode by pressing the LOCAL key, the data could be lost. This would leave the Measuring Receiver in an unknown state. To prevent this, a local lockout is recommended. Local lockout disables the LOCAL key (and the CLEAR key) and allows return-to-local only under program control.

NOTE

Return-to-local can also be accomplished by turning the Measuring Receiver's POWER switch to STBY, then back to ON. However, this technique has several disadvantages:

- It defeats the purpose and advantages of local lockout (that is, the system controller will lose control of a system element).
- There are several HP-IB conditions that reset to default states at turn-on.

Limit (Cont'd)
(Special Function 14)

Procedures (cont'd)

The Special Function codes pertaining to the Limit function are listed in the following table:

	Action	Special Function Code	Program Code ↔HP-IB↔
Limit	Clear limits; turn off LIMIT annunciator.	14.0 SPCL	14.0SP
	Set lower limit to RATIO reference.	14.1 SPCL	14.1SP
	Set upper limit to RATIO reference.	14.2 SPCL	14.2SP
	Restore lower limit.	14.3 SPCL	14.3SP
	Restore upper limit.	14.4 SPCL	14.4SP
	Display lower limit.	14.5 SPCL	14.5SP
	Display upper limit.	14.6 SPCL	14.6SP
	Display selected, lower limit measurement code.	14.7 SPCL	14.7SP
	Display selected, upper limit measurement code.	14.8 SPCL	14.8SP
	Display limit status in the format Lower.Upper; where 0=disabled and 1=enabled.	14.9 SPCL	14.9SP

To determine the measurement in which a lower or upper limit is in effect, key in Special Function 14.7 or 14.8 (respectively). The display shows a code which represents the measurement in which the limit is in effect. These codes are indexed in the following table:

Display	Measurement	Display	Measurement
0.000	AM	0.011	AUDIO FREQ (external)
0.001	FM	2.003	RF LEVEL (35.0 SPCL)
0.002	ϕ M	2.004	PEAK TUNED RF LEVEL (36.0 SPCL)
0.003	RF POWER	2.009	AUDIO DISTN (internal)
0.004	TUNED RF LEVEL	2.010	LO FREQUENCY (33.0 SPCL)
0.005	FREQ	2.011	AUDIO DISTN (external)
0.006	FREQ ERROR	4.009	SINAD (internal)
0.008	IF LEVEL	4.011	SINAD (external)
0.009	AUDIO FREQ (internal)	6.011	EXT AUDIO RMS LEVEL (30.0 SPCL)
0.010	IF FREQUENCY (34.0 SPCL)		



3-17. Data Messages

The Measuring Receiver communicates on the interface bus primarily with data messages. Data messages consist of one or more bytes sent over the bus' 8 data lines when the bus is in the data mode (attention control line [ATN] false). Unless it is set to Talk Only, the Measuring Receiver receives data messages when addressed to listen. Unless it is set to Listen Only, the Measuring Receiver sends data messages or the Status Byte message (if enabled) when addressed to talk. Virtually all instrument operations available in local mode can be performed in remote mode via data messages. The only exceptions are changing the POWER switch setting and using the Controller Reset Service Special Function. In addition, the Measuring Receiver can be triggered via data messages to make measurements at a particular time.

3-18. Receiving the Data Message

Depending on how the internal address switches are set, the Measuring Receiver can either talk only, talk status only, listen only, or talk and listen both (normal operation). The instrument responds to Data messages when it is enabled to remote (REN control line true) and it is addressed to listen or set to Listen Only. If not set to Listen Only, the instrument remains addressed to listen until it receives an Abort message or until its talk address or a universal unlisten command is sent by the controller.

Listen Only. If the internal LON (Listen Only) switch is set to "1", the Measuring Receiver is placed in the Listen Only mode when the remote enable bus control line (REN) is set true. The instrument then responds to all Data messages, and the Trigger, Clear, and Local Lockout messages. However, it is inhibited from responding to the Local or Abort messages and from responding to a serial poll with the Status Byte message.

Listen Only mode is provided to allow the Measuring Receiver to accept programming from devices other than controllers (for example, card readers).

Data Input Format. The Data message string, or program string, consists of a series of ASCII codes. Each code is typically equivalent to a front-panel keystroke in local mode. Thus, for a given operation, the program string syntax in remote mode is the same as the keystroke sequence in local mode. Example 1 shows the general case programming order for selecting Measuring Receiver functions. Specific "program order considerations" are discussed in this section. All functions can be programmed together as a continuous string as typified in Example 2. The string in Example 2 triggers a settled measurement cycle in which the Measuring Receiver determines the positive peak de-emphasized (75 us) FM deviation of an input signal at 104.5 MHz.

Limit (Special Function 14)

Description

Using Special Function 14 and the RATIO key, lower and upper measurement limits can be entered into the Measuring Receiver. Subsequent out-of-limit measurements will then cause the LIMIT annunciator to be displayed.

When the Limit function is enabled, the Measuring Receiver can issue an HP-IB service request upon reaching an lower or upper limit. (Refer to Service Request Condition.) The LIMIT light turns off after 5 measurement cycles if further measurements are not out of limits; but the service request can only be cleared by serial polling or by a Device Clear or Instrument Preset message.

Only one lower and one upper limit can be set at a time. Each limit (lower or upper) can only be in effect in one Measurement mode. (The Measurement mode need not be the same for both the lower and upper limits.) Both limit references can be displayed, cleared and restored; the status of the Limit function can be displayed; and the Measurement modes for both limits can be displayed.

Procedures

First enter the desired limit reference as a ratio reference:

1. Select the measurement key in which the limit is to be used.
2. Key the limit value into the numeric keyboard. Use the Blue Key and the minus (-, decimal point) key to change the sign of the entered value.
3. Press the RATIO key.

The entered value is now stored as a ratio reference. To transform the ratio reference directly into a lower or upper limit reference, key in Special Function 14.1 or 14.2 (respectively).

Press the RATIO key again to re-display the measurement value.

Receiving the Data Message (Cont'd)

EXAMPLE 1: General Program Syntax and Protocol-----

{Controller Talk}
{Measuring Receiver Listen},

[Automatic Operation] [Measurement] [Detector] [Filters] [FM De-emphasis] [Special Functions] [Ratio] [Calibration] [Trigger]

EXAMPLE 2: Typical Program String-----

{Controller Talk}
{Measuring Receiver Listen},

	<u>AU</u>	<u>104.5MZ</u>	<u>M2</u>	<u>D1</u>	<u>P1</u>	<u>P4</u>	<u>T3</u>	
Automatic Operation----								--Trigger w/ Settling
Manual Tuning-----								---75 us FM De-Emphasis
		FM--						--FM De-Emphasis Pre-Display
								Peak+ Detector

Program Codes. Table 3-1 lists the Measuring Receiver's response to various ASCII characters not used in its code set. The characters in the left-hand column are ignored unless they appear between two characters of a program code. The characters in the right-hand column, if received by the Measuring Receiver, will always cause Error 24 (invalid HP-IB code) and a Require Service message to be generated. As a convenience, all lower case alpha characters are treated as upper case.

The valid HP-IB codes for controlling Measuring Receiver functions are summarized in Table 3-2 (and on the Operating Instructions pull-out card). All front-panel keys except the LOCAL key have corresponding program codes. Some of the tuning functions have additional codes which terminate the numeric data entry in Hz rather than MHz or kHz as indicated on the front panel. The codes provided are the codes used in all programming examples in this manual.

Turning Off Functions. When operating in local mode, many of the functions toggle on and off with successive keystrokes. In remote mode, these functions do not toggle on and off. Instead, a specific code turns off the keys. (Note that for FM De-emphasis, the code that turns off the filters also turns off the PRE DISPLAY function. Thus, when programming FM de-emphasis, it is advantageous to begin with the PRE DISPLAY setting, then select the desired de-emphasis.)

Instrument Preset (Cont'd)
(Includes all Power-up and Default Conditions as well as
Special Functions 40 and 41, and **HP-IB** Clear)

Procedures

To walk the instrument through its internal checks, key in 40.0 SPCL or turn the Measuring Receiver off, then on again.

To reset the Measuring Receiver to its default conditions without going through the 10 second process of internal checks, press the Blue Key and INSTR PRESET (AUTOMATIC OPERATION) key, or key in 41.0 SPCL.

HP-IB Program Codes

Special Function 40.0 is not accessible from the HP-IB.

INSTR PRESET (Device Clear) = IP
SPCL = SP

Comments

After plugging in a new Memory Assembly, some or all of the instrument states stored through power-down may be non-existent. If this information is lost:

1. The Recall function selects the Instrument Preset state.
2. Error.15 is displayed and RF power calibration factors must be re-entered.
3. Synchronous and Average Tuned RF Level calibration factors are displayed as 0.0%.
4. AM and FM calibration factors are 100% when enabled.



Receiving the Data Message (Cont'd)

Table 3-1. Measuring Receiver Response to Unused ASCII Codes

Ignored*	Generate Error 24
!	@
"	B \
"	G
#	I)
%	J -
&	N {
(Q
)	V }
*	W ~
,	Y DEL
/	

*Except when inserted between two characters of a program code.

Programming Numeric Data. When programming input frequency, entering ratio or limit references, or issuing any numeric data (other than specific HP-IB codes) to the Measuring Receiver, certain precautions should be observed. Numeric data may consist of a mantissa of up to eight digits, one decimal point, and one- or two-digit signed exponent. The decimal point may fall between any two digits of the mantissa but may not appear ahead of the first digit. If it does, a leading zero will be automatically inserted by the Measuring Receiver. Any digit beyond the ten allowed for the mantissa will be received as zero. In general, do not issue numeric data with more significant digits than can be displayed on the Measuring Receiver's 10-digit display.

Triggering Measurements with the Data Message. A feature that is only available via remote programming is the selection of free run, standby, or triggered operation of the Measuring Receiver. During local operation, the Measuring Receiver is allowed to free run, outputting data to the display each measurement cycle. In remote, three additional operating modes are allowed: Hold, Trigger Immediate, and Trigger With Settling. In addition, the CLEAR key can act as a manual trigger while the instrument is in remote. The trigger modes and use of the Clear key are described below.

Free Run (T0). This mode is identical to local operation and is the mode of operation in effect when no other trigger mode has been selected. The measurement result data available to the bus are constantly being updated as rapidly as the Measuring Receiver can make measurements. A Device Clear message or entry into remote from local sets the Measuring Receiver to the Free Run mode.

Instrument Preset (Cont'd)
 (Includes all Power-up and Default Conditions as well as
 Special Functions 40 and 41, and **HP-IB** Clear)

Description (cont'd)

Default conditions after power-up:

Front-Panel Keys

HP FILTER	all off
LP FILTER	all off
FM DE-EMPHASIS	all off
PRE DISPLAY	off
CALIBRATION	all off
RF POWER ZERO	previous power-down value
RF POWER SAVE CAL.	previous power-down value
MEASUREMENT	FREQ
DETECTOR	PEAK+
DISPLAY	off
RATIO	off
AUTOMATIC OPERATION	on
TRACK MODE	off
AUTO TUNING	on
RANGE HOLD	off
DISABLE ERROR	as appropriate for selected measurement
MHz	when pressed, 100 MHz
kHz \uparrow and kHz \downarrow	0 kHz
MODULATION OUTPUT	FM

Special Functions

1-10	suffix is set to 0
11 Previous Ratio	off
Ratio Reference	100%
14 Limit	off
Upper Limit	1300
Lower Limit	0.150
Upper/Lower Limit Code	0.005 (FREQ)
16 AM Calibration Factors	100% or previous power-down value
17 FM Calibration Factors	100% or previous power-down value
22 Service Request	suffix set to 2
Status Byte	cleared
25 External Attenuation	0 dB
26 Set Reference	0 dBm
27 Frequency Offset Control	0 MHz
37 Calibration Factors, RF Power	Table #1 from previous power-down
Mode	Automatic Cal Factor Mode
38, 39 Calibration Factors, Tuned RF Level	4 calibration factors and RF and IF filters from previous power-down



Receiving the Data Message (Cont'd)

Hold (T1). This mode is used to set up triggered measurements (initiated by program codes T2 or T3, the Trigger message, or the CLEAR key). In Hold mode, internal settings can be altered by the instrument itself or by the user via the bus. Thus, the output signal at MODULATION OUTPUT/AUDIO INPUT can change. However, the instrument is inhibited from outputting any data to the front-panel key lights and display or to the HP-IB except as follows: The instrument will issue the Require Service message if a LIMIT is reached (and if enabled to do so) or if an HP-IB code error occurs. The instrument will issue the Status Byte message if serial polled. (A serial poll, however, will trigger a new measurement, update displays and return the instrument to Hold.) If a momentary error condition occurs while the instrument is in Hold, the output signal at MODULATION OUTPUT/AUDIO INPUT may be temporarily invalid with no indication from the instrument.

Upon leaving Hold, the front-panel indications are updated as the new measurement cycle begins. The Status Byte will be affected (and the Require Service message issued) by the events that occur during the new measurement cycle. The Measuring Receiver leaves Hold when it receives either the Free Run, Trigger Immediate, Trigger With Settling codes, or the Trigger Message; when the CLEAR key is pressed (if not in Local Lockout); or when it returns to local operation.

Trigger Immediate (T2). When the Measuring Receiver receives the Trigger Immediate code, it makes one measurement in the shortest possible time. The instrument then waits for the measurement results to be read. While waiting, the instrument can process most bus commands without losing the measurement results. However, if the instrument receives GTL (Go To Local), GET (Group Execute Trigger), or its listen address or if it is triggered by the CLEAR key, a new measurement cycle will be executed. Once the data (measurement results) are read onto the bus, the Measuring Receiver reverts to the Hold mode. Measurement results obtained via Trigger Immediate are normally valid only when the instrument is in a steady, settled state.

Trigger With Settling (T3). Trigger With Settling is identical to Trigger Immediate except the Measuring Receiver inserts a settling-time delay before taking the requested measurement. This settling time is sufficient to produce valid, accurate measurement results. Trigger With Settling is the trigger type executed when a Trigger message is received via the bus.

NOTE

The use of Trigger With Settling does not remove the need to observe the normal warm-up precautions when using either the RF Power, AM, or FM Calibrator. Refer to the procedures "RF Power Calibration", "AM Calibration", or "FM Calibration" in the Detailed Operating Instructions.

Instrument Preset
(Includes all Power-Up and Default Conditions as well as
Special Functions 40 and 41, and **HP-IB** Clear)

Description

When first turned on (during power-up), the Measuring Receiver walks through a sequence of internal checks before it is ready to make measurements. The results of these checks are indicated internally to aid servicing. (Refer to Section VIII.) This power-up sequence is indicated to the user when all front-panel indicators are lighted (burned-out LEDs are evident at this time). After approximately 10 seconds, this sequence is completed. Special Function 40 also performs the power-up sequence.

When the INSTR PRESET key is pressed, or Special Function 41 (Device Clear) is keyed, the instrument configures itself the same as during power-up, but bypasses the internal checks.

The Measuring Receiver contains a battery back-up to the RAMs which makes the internal memory non-volatile, enabling certain aspects of the instrument setup to be maintained after the power has been switched off (power-down).

Maintained during power-down:

- Storage of 8 instrument states using the Store and Recall function. (Refer to Store/Recall.)
- For RF Power:
 1. One set of zero and calibration data. (Refer to RF Power Calibration.)
 2. Two calibration factor tables: One table stores 16 frequency/calibration factor pairs and a reference calibration factor for use with RF power sensors. One table stores 22 frequency/calibration factor pairs for use with microwave power sensors. (Refer to RF Power Calibration Factors.)
- For Synchronous and Average Tuned RF Level:
 1. Four calibration factors.
 2. The frequency at which the calibration factors are valid.
 3. The state of the RF High-Pass Filter, Wide IF Filters, and Narrow IF Filters at the time of calibration.
- For AM and FM:

An AM calibration factor and an FM calibration factor (both in disabled mode). (Refer to AM Calibration and FM Calibration.)



Receiving the Data Message (Cont'd)

Triggering Measurements With the CLEAR Key. When the Measuring Receiver is in remote Hold mode and not in Local Lockout, the front-panel CLEAR key may be used to issue a Trigger With Settling instruction. First place the instrument in Hold mode (code T1). Each time the CLEAR key is pressed, the Measuring Receiver performs one Trigger With Settling measurement cycle, then waits for the data to be read. Once the data is read out to the bus, the instrument returns to Hold mode. If data is not read between trigger cycles, it will be replaced with data acquired from subsequent measurement cycles.

Special Considerations for Triggered Operation. When in free-run mode, the Measuring Receiver must pay attention to all universal bus commands, for example, serial poll enable (SPE), local lockout (LLO), etc. In addition, if it is addressed to listen, it must pay attention to all addressed bus commands, for example, go to local (GTL), group execute trigger (GET), etc. As a consequence of this, the Measuring Receiver must interrupt the current measurement cycle to determine whether any action in response to these commands is necessary. Since many elements of the measurement cycle are transitory, the cycle must be reinitiated following each interruption. Thus, if a lot of bus activity occurs while the Measuring Receiver is trying to take a measurement, a measurement cycle may never be completed.

Trigger Immediate and Trigger With Settling provide a way to avoid this problem. When the Trigger Immediate (T2) and Trigger With Settling (T3) codes are received, the Measuring Receiver will not allow its measurement cycle to be interrupted. (Indeed, handshake of bus commands is inhibited until the measurement cycle is complete.) Once the cycle is complete, bus commands will be processed, as discussed under Trigger Immediate above, with no loss of data. Thus, in an HP-IB environment where many bus commands are present, Trigger Immediate or Trigger With Settling should be used for failsafe operation.

Program Order Considerations. Although program string syntax is virtually identical to keystroke order, some program order considerations need highlighting:

AUTOMATIC OPERATION (AU). As in local mode, when AUTOMATIC OPERATION is executed in remote it sets all Special Functions prefixed 1 through 10 to their zero-suffix mode and also affects many other Special Functions. Thus when AUTOMATIC OPERATION is used, it should appear at the beginning of a program string.

FM DE-EMPHASIS PRE DISPLAY (P0 AND P1). When pre-display is turned off using P0, all FM de-emphasis is turned off. To avoid mistakes when programming de-emphasis, always arrange the codes in numeric order specifying the PRE DISPLAY setting (P0 or P1) first.

IF Output (Cont'd)

Comments (cont'd)

Check that instruments (such as counters), connected to IF OUTPUT, do not inject spurious signals into the IF path. These spurious signals can cause spurs in the Measuring Receiver's IF circuits which could result in measurement inaccuracies.

Related Functions

Filters, RF and IF
IF Frequency



Receiving the Data Message (Cont'd)

PEAK HOLD (D3). As in local, once PEAK HOLD is specified any ensuing detector code will turn it off. Thus the peak to be held must be specified before PEAK HOLD is activated. A good rule to follow is to specify detectors in numeric order.

Trigger Immediate and Trigger With Settling (T2 and T3). When either of the trigger codes T2 or T3 is received by the Measuring Receiver, a measurement cycle is immediately initiated. Once the measurement cycle is complete, some bus commands can be processed without losing the measurement results. However, any HP-IB program code sent to the Measuring Receiver before the triggered measurement results have been output will initiate a new measurement cycle. Thus, trigger codes should always appear at the end of a program string, and the triggered measurement results must be read before any additional program codes are sent.

3-19. Sending The Data Message

Depending on how the internal address switches are set, the Measuring Receiver can either talk only, talk status only, listen only, or talk and listen both (normal operation). If set to both talk and listen, the instrument sends Data messages when addressed to talk. The instrument then remains configured to talk until it is unaddressed to talk by the controller. To unaddress the Measuring Receiver, the controller must send either an Abort message, a new talk address, or a universal untalk command.

Talk Only Mode. If the internal address switches are set to a valid Talk address and the TON (Talk Only) switch is set to "1", the Measuring Receiver is placed in the Talk Only mode. In this mode the instrument is configured to send Data messages whenever the bus is in the data mode. Each time the measurement is completed, the measurement result will be output to the bus unless the listening device is not ready for data. If the listener is not ready and the Measuring Receiver is not in a trigger mode, another measurement cycle is executed.

Talk Status Only Mode. If all the internal address switches and the TON (Talk Only) switch are set to "1", but the LON (Listen Only) switch is set to "0", the Measuring Receiver is placed in the Talk Status Only mode. In this mode the instrument is configured to send a one-byte data message whenever the bus is in the data mode. The byte sent is an exact copy of the Status Byte. Each time this byte is successfully sent on the bus, the internal Status Byte is cleared. The Data Valid (DAV) handshake line is pulsed each time the one-byte Data message is sent.

IF Output

CAUTION

Do not apply greater than 40 Vdc or greater than +15 dBm into the rear-panel IF OUTPUT connector.

Description

The rear-panel IF OUTPUT (a female BNC connector) provides a buffered IF output to enable monitoring of the Measuring Receiver's IF signal. The ac-coupled signal ranges from 150 kHz to 2.5 MHz and normally varies in level from -27 to -3 dBm (into 50 ohms). The level variation depends on the RF input signal level, RF input attenuation/gain setting, and the measurement selected.

The 3 dB bandwidth of the signal at IF OUTPUT is approximately 3 MHz when the instrument uses the wide, 2.5 MHz low-pass filter; approximately 200 kHz when the instrument uses the wide, 455 kHz bandpass filter; and approximately 30 kHz when the instrument uses the narrow, 455 kHz bandpass filter.

At any particular input level and front-panel setting, the flatness of the IF OUTPUT, as input frequency varies, is typically $\pm 5\%$.

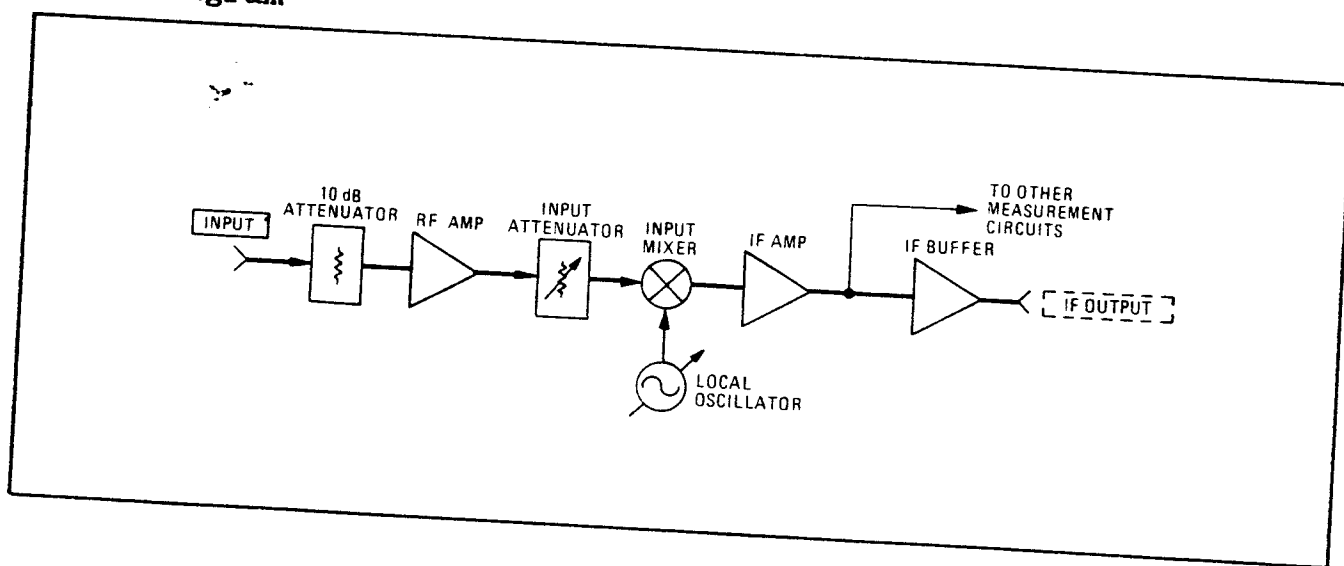
Block Diagram

IF Output Block Diagram

Comments

The Measuring Receiver can be used as a down-converter. Use IF OUTPUT as the down-converter's output.

Check for spurious signals in the IF by connecting a spectrum analyzer to IF OUTPUT.



Sending the Data Message (Cont'd)

Data Output Format. As shown below, the output data is always formatted as a real constant: first the sign, then 10 digits (leading zeros not suppressed) followed by the letter E and a signed power-of-ten multiplier. The string is terminated by a carriage return (CR) and a line feed (LF), string positions 14 and 15. Data is always output in fundamental units (for example, Hz, watts, radians, dB, %, etc.), and the decimal point (not sent) is assumed to be to the right of the tenth digit of the mantissa. Data values never exceed 4 000 000 000.

Data Output Format:

+	<u>DDDDDDDDDD</u>	E	+	<u>NN</u>	<u>CR</u>	<u>LF</u>	
Signed Mantissa----							-----Line Feed
Indicates Exponent Follows---							---Carriage Return
Exponent Sign-----							---Exponent Magnitude

When an error is output to the bus, it follows the same fifteen-byte format described above except most of the numeric digits have predetermined values as shown below. Error outputs always exceed 90 000 000 000. The two-digit error code is represented by the last two digits of the eight-digit mantissa. The error code can be derived from the string by subtracting 9×10^{10} , then dividing the results by 1000.

Error Output Format:

+900000	<u>DD</u>	00	E+01	<u>CR</u>	<u>LF</u>	
Error Code--						----Line Feed
						--Carriage Return

Timed Displays in Remote Operation. When operating in local mode, many Measuring Receiver displays are presented only for a limited time. This allows the instrument to communicate requested information or error messages, then return to displaying the results of the measurement previously selected. In remote, no measurement result, outputs, or displays are timed. Error outputs, however, time-out as they do in local operation unless captured during a triggered measurement cycle.

3-20. Receiving the Clear Message

The Measuring Receiver responds to the Clear message by assuming the settings listed in the Detailed Operating Instruction, "Instrument Preset". The Measuring Receiver responds equally to the Selected

IF Level (Cont'd)

Measurement Technique (cont'd)

available, the IF level is automatically adjusted to a preset ALC reference level to display 100%. If the ALC loop is open (Special Function 6.2), the input attenuator and the input signal level can be adjusted to achieve the 100% level.

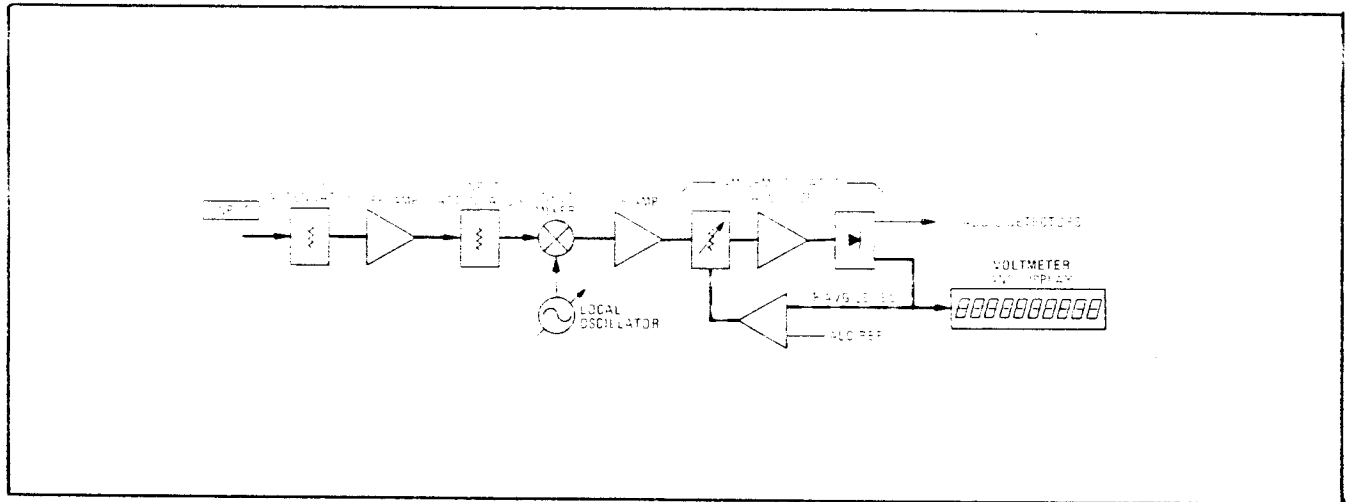

IF Level Measurement Block Diagram

Comments

Error 03 (input circuits underdriven) is generated whenever the IF level is less than 100%. Override this error message using Special Function 8. (Refer to Disable Error Message Control.)

When operating with the AM ALC loop open, the displayed AM represents the demodulated ac riding on the carrier; the displayed IF level represents the average carrier level. Compute the AM depth with the following formula:

$$\frac{\text{demodulated ac}}{\text{average carrier level}} \times 100\% = \frac{\text{displayed AM}}{\text{displayed IF level}} \times 100\%$$

To enable the Measuring Receiver to do this computation, first observe the IF level, press the AM key and enter the IF level on the numeric keys. Then press the RATIO key. AM is now displayed accurately although the measured IF level is not 100%.

In most circumstances, when the AM ALC is off (loop open), use IF levels greater than or equal to 100% for FM measurements and less than or equal to 100% for AM measurements.

Related Functions

AM ALC Response Time



Receiving the Clear Message (Cont'd)

Device Clear (SDC) bus command when addressed to listen, and the Device Clear (DCL) bus command whether addressed or not. The Clear message clears any pending Require Service message and resets the Service Request Condition (Special Function 22) such that the Require Service message will be issued on HP-IB code errors only (22.2 SPCL).

3-21. Receiving the Trigger Message

When in remote and addressed to listen, the Measuring Receiver responds to a Trigger message by executing one settled-measurement cycle. The Measuring Receiver responds equally to a Trigger message (the Group Execute Trigger bus command [GET]) and a Data message, program code T3 (Trigger With Settling). Refer to "Triggering Measurements With the Data Message" that appears earlier in this section.

3-22. Receiving the Remote Message

The Remote message has two parts. First, the remote enable bus control line (REN) is held true, then the device listen address is sent by the controller. These two actions combine to place the Measuring Receiver in remote mode. Thus, the Measuring Receiver is enabled to go into remote when the controller begins the Remote message, but it does not actually switch to remote until addressed to listen the first time. No instrument settings are changed by the transition from local to remote, but the Trigger mode is set to Free Run (code T0). When actually in remote, the Measuring Receiver lights its front-panel REMOTE annunciator. When the Measuring Receiver is being addressed (whether in remote or local), its front-panel LISTEN or TALK annunciator turns on.

3-23. Receiving The Local Message

The Local message is the means by which the controller sends the Go To Local (GTL) bus command. If addressed to listen, the Measuring Receiver returns to front-panel control when it receives the Local message. If the instrument was in local lockout when the Local message was received, front-panel control is returned, but lockout is not cleared. Unless it receives the Clear Lockout-Set Local message, the Measuring Receiver will return to local lockout the next time it goes to remote. No instrument settings are changed by the transition from remote to local, but all measurements are made in a free run mode.

When the Measuring Receiver goes to local mode, the front-panel REMOTE annunciator turns off. However, when the Measuring Receiver is being addressed (whether in remote or local), its front-panel LISTEN or TALK annunciator lights.

IF Level

Description

The IF LEVEL key enables the Measuring Receiver to measure the signal level in its IF and display this value as a percent of the optimum level. An IF level display of 100% indicates sufficient signal strength to guarantee accurate AM, FM, and ϕ M measurements.

When IF LEVEL is selected, the output at MODULATION OUTPUT/AUDIO INPUT continues to output the demodulated signal corresponding to the last modulation measurement selected. If, however, the IF level is not 100%, the calibration of the modulation output signal is not specified.

Procedures

To display the IF level as a percent of optimum, press the S (shift) key, then the IF LEVEL key.

If IF level is to be displayed relative to some reference level, enter the value as a ratio reference using the RATIO key. (Refer to Ratio.)

HP-IB Program Code

IF LEVEL = S3

Indications

Display: When the IF LEVEL key is pressed, the optimum IF level is displayed in % or dB (as selected by the LOG/LIN key). The % or dB annunciator is also displayed.

Front Panel: The LEDs within the S (shift) key and the IF LEVEL key light. The value in the display will show the percent of optimum IF Level.

Measurement Technique

Once the instrument is tuned and the IF Level function is selected, the automatic level control (ALC) loop of the AM Demodulator detects the average IF signal level. The measured IF Avg Level is compared to an ALC reference and then displayed as a percentage of the optimum level. If the ALC loop is closed and sufficient signal power is



Receiving the Local Message (Cont'd)

If the Measuring Receiver is not in local lockout mode, pressing the front-panel LOCAL key might interrupt a Data message being sent to the instrument, leaving the instrument in a state unknown to the controller. This can be prevented by disabling the Measuring Receiver's front-panel keys entirely using the Local Lockout message.

3-24. Receiving the Local Lockout Message

The Local Lockout message is the means by which the controller sends the Local Lockout (LLO) bus command. If in remote, the Measuring Receiver responds to the Local Lockout Message by disabling the front-panel LOCAL and CLEAR keys. (In remote, CLEAR initiates a Trigger With Settling cycle.) The local lockout mode prevents loss of data or system control when someone accidentally presses front-panel keys. If, while in local, the Measuring Receiver is enabled to remote (that is, REN is set true) and it receives the Local Lockout message, it will switch to remote mode with local lockout the first time it is addressed to listen. When in local lockout, the Measuring Receiver can be returned to local only by the controller (using the Local or Clear Lockout/Set Local messages) or by setting the POWER switch to STBY and back to ON or by removing the bus cable.

3-25. Receiving the Clear Lockout/Set Local Message

The Clear Lockout/Set Local message is the means by which the controller sets the Remote Enable (REN) bus control line false. The Measuring Receiver returns to local mode (full front-panel control) when it receives the Clear Lockout/Set Local message. No instrument settings are changed by the transition from remote with local lockout to local. When the Measuring Receiver goes to local mode, the front-panel REMOTE annunciator turns off.

3-26. Receiving the Pass Control Message

The Measuring Receiver does not respond to the Pass Control message because it cannot act as a controller.

3-27. Sending the Require Service Message

The Measuring Receiver sends the Require Service message by setting the Service Request (SRQ) bus control line true. The instrument can send the Require Service message in either local or remote mode. The Require Service message is cleared when a serial poll is executed by the controller or if a Clear message is received by the Measuring Receiver. (During serial poll, the Require Service message is cleared immediately before the Measuring Receiver places the Status Byte message on the bus.) An HP-IB code error will always cause a Require Service message to be issued. In addition, there are six other conditions which can be enabled to cause the Require Service message to be sent when they occur. Refer to "Service Request Condition" in the Detailed Operating Instructions.

IF Frequency (Cont'd) (Special Function 34.0)

Measurement Technique (cont'd)

Receiver uses either the 455 kHz or 1.5 MHz IF. For RF input frequencies less than 2.5 MHz no down-conversion is necessary and the input signal is passed directly into the IF. The frequency of the IF signal is counted and displayed.

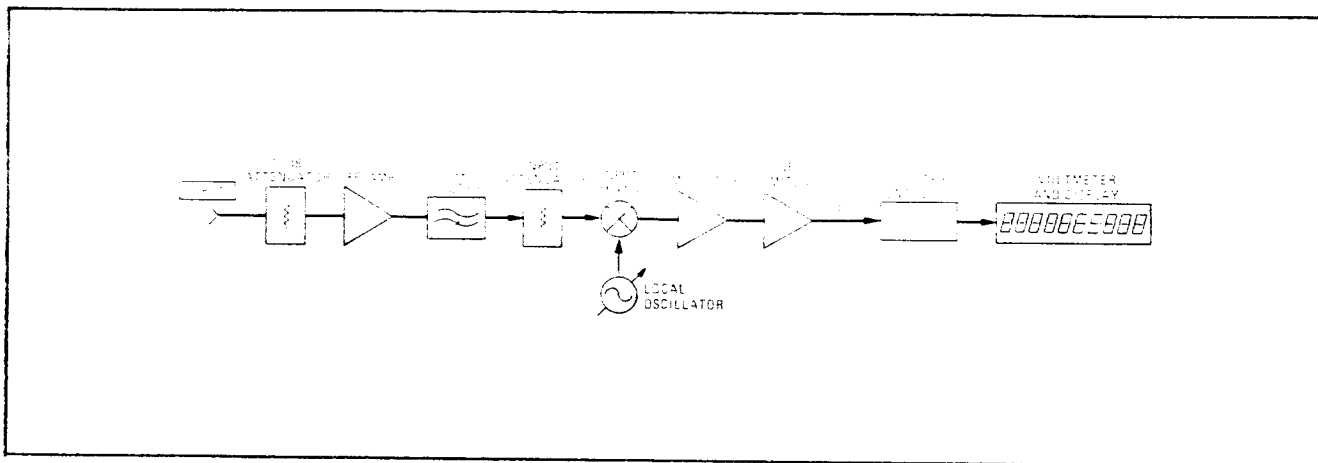

IF Frequency Measurement Block Diagram

Comments

Normally, the counter updates the display five times each second. For selection of other resolutions, refer to **RF Frequency Resolution**. (Note that counter accuracy is the reference accuracy ± 3 counts.)

RF filter selection is dependent on the selected IF Frequency. (Refer to **Filters, RF and IF**.)

When using the 455 kHz IF on input signals with frequencies greater than 300 MHz, AM due to FM increases substantially.

The Measuring Receiver determines the frequency of the RF input signal by counting the frequencies of both the IF and LO, and calculating their difference.

When measuring frequencies less than 2.5 MHz, the value of the IF frequency is equal to the value of the RF input frequency.

The calibration of the output signal available at **MODULATION OUTPUT/AUDIO INPUT** depends on the IF signal level and should be assumed only when all errors are enabled (**Special Function 8.8**).

Related Functions

Disable Error Message Control
Filters, RF and IF
LO Frequency

RF Frequency Resolution •
RF Input Frequency
Special Functions



3-28. Selecting the Service Request Condition

Use Special Function 22, Service Request Condition, to enable the Measuring Receiver to issue the Require Service message. HP-IB code errors always cause the Require Service message to be sent. The Service Request Condition Special Function is entered from either the front panel or via the HP-IB. The conditions enabled by Special Function 22 are always disabled by the Clear message. A description of the Service Request Condition Special Function and the procedure for enabling the various conditions are provided under "Service Request Condition" in the Detailed Operation Instructions.

Normally, device subroutines for the Measuring Receiver can be implemented simply by triggering measurements, then reading the output data. In certain applications, the controller must perform other tasks while controlling the Measuring Receiver. A device subroutines structure, using the instrument's ability to issue the Require Service message when data is ready, frees the controller to process other routines until the Measuring Receiver is ready with data.

3-29. Sending the Status Byte Message

The Status Byte message consists of one 8-bit byte in which 7 of the bits are set according to the enabled conditions described in "Sending the Require Service Message" discussed earlier in this section.

If any of the conditions enabled by Special Function 22 are enabled and present, all the bits corresponding to the conditions and also bit 7, the RQS bit, will be set true (and the Require Service message sent). The front-panel SRQ annunciator turns on. If one these conditions occurs but has not been enabled by Special Function 22, neither the bit corresponding to the condition nor the RQS bit will be set (and the Require Service message will not be sent).

Once the Measuring Receiver receives the serial poll enable bus command (SPE), it is no longer allowed to alter the Status Byte. When addressed to talk (following SPE), the Measuring Receiver sends the Status Byte message.

NOTE

Since the Measuring Receiver cannot alter the Status Byte while in serial poll mode, it is not possible to continually request the Status Byte while waiting for a condition to cause a bit to be set.

After the Status Byte message has been sent it will be cleared if the Serial Poll Disable (SPD) bus command is received, if the Abort message is received, or if the Measuring Receiver is unaddressed to

IF Frequency (Special Function 34.0)

Description

The Measuring Receiver only characterizes RF input signals that can pass through its intermediate frequency (IF) filters. Three ways are used to pass the RF input signal through the IF:

When RF input signals less than 2.5 MHz are measured, the RF input signal passes directly into the IF; that is, the RF input frequency and the IF frequency are the same.

When RF input signals greater than 2.5 MHz, but less than 10 MHz are measured, the signal is down converted to a 455 kHz IF. (The 455 kHz IF is also selected when making Synchronous or Average Tuned RF Level Measurements; irrespective of RF frequency. Refer to Tuned RF Level.)

When RF input signals greater than 10 MHz are measured, the signal is down-converted to a 1.5 MHz IF.

Special Function 34.0 enables the Measuring Receiver to display the IF signal being used with the selected measurement.

When the instrument is measuring IF frequency, the signal at MODULATION OUTPUT/AUDIO INPUT remains unchanged.

Procedures

To measure the IF frequency, enter the numeric code 34.0, then press the SPCL key.

If IF frequency is to be displayed relative to a reference, enter the value as a ratio reference using the RATIO key. (Refer to Ratio.)

HP-IB Program Code

SPCL = SP

Indications

Display: As the numeric code is entered, it appears on the display. When the SPCL key is pressed, the IF frequency is displayed (in MHz). The MHz annunciator is also displayed.

Front Panel: All measurement key lights turn off and the LED within the SPCL key lights.

Measurement Technique

The IF signal, generated when the Local Oscillator and the RF input signal mix, is amplified by the IF Amplifier and FM Limiters. When measuring RF input frequencies greater than 2.5 MHz, the Measuring



Sending the Status Byte Message (Cont'd)

talk. Regardless of whether or not the Status Byte message has been sent, the Status Byte and any Require Service message pending will be cleared if a Clear message is received. If the instrument is set to Talk Only, the Status Byte is cleared each time the one-byte Data message is issued to the bus.

3-30. Sending the Status Bit Message

The Measuring Receiver does not respond to a Parallel Poll Enable (PPE) bus command and thus cannot send the Status Bit message.

3-31. Receiving the Abort Message

The Abort message is the means by which the controller sets the Interface Clear (IFC) bus control line true. When the Abort message is received, the Measuring Receiver becomes unaddressed and stops talking or listening.

IF Gain (Cont'd)
(Special Function 9)

Comments

When the instrument is first powered up, or when AUTOMATIC OPERATION or INSTR PRESET is selected, the IF Gain function is placed in the automatic selection mode.

Related Functions

LO Frequency
Special Functions



Table 3-2. Measuring Receiver to HP-IB Code Summary

MEASUREMENT	CODE	CALIBRATION	CODE
AM	M1	CALIBRATE Off	C0
FM	M2	CALIBRATE On	C1
ϕ M	M3	% CAL FACTOR	CF
RF POWER	M4	SET REF	RF
FREQ	M5	SAVE CAL	SC
AUDIO FREQ	S1	MANUAL OPERATION	CODE
AUDIO DISTN	S2	AUTO TUNING	AT
IF LEVEL	S3	ENABLE ERRORS	B0
TUNED RF LEVEL	S4	DISABLE ERROR	B1
FREQ ERROR	S5	CLEAR	CL
DETECTOR	CODE	DISPLAY FREQ	FR
PEAK+	D1	DISPLAY INCREMENT	FN
PEAK-	D2	Step Up (Hz)	HU
PEAK HOLD	D3	Step Down (Hz)	HD
AVG	D4	INPUT FREQUENCY(Hz)	HZ
1 kHz DISTN	D5	TRACK Mode Off	K0
400 Hz DISTN	D6	TRACK Mode On	K1
RMS	D8	Step Up (kHz)	KU
PEAK \pm /2	D9	Step Down (kHz)	KD
DISPLAY	CODE	mV Units	MV
Display LOG Result	LG	MHz (INPUT FREQ)	MZ
Display LIN Result	LN	RECALL	RC
dB EXT ATTEN Off	N0	SPECIAL FUNCTION	SP
dB EXT ATTEN On	N1	SPECIAL, SPECIAL	SS
RATIO Off	R0	STORE	TR
RATIO On	R1	μ V Units	UV
PREVIOUS RATIO	R2	V Units	VL
FILTERS	CODE	W Units	WT
HP FILTERs Off	H0	MISCELLANEOUS	CODE
50 Hz HIGH-PASS On	H1	MODULATION OUTPUT	A0
300 Hz HIGH-PASS On	H2	AUDIO INPUT	A1
LP FILTERs Off	L0	AUTOMATIC OPERATION	AU
3 kHz LOW-PASS On	L1	Automatic Ranging	G0
15 kHz LOW-PASS On	L2	RANGE HOLD	G1
>20 kHz On	L3	Identify Instrument	ID
FM DE-EMPHASIS	CODE	INSTR PRESET	IP
FM DE-EMPHASIS Off and		Trigger Off	T0
PRE-DISPLAY Off	P0	Hold	T1
PRE-DISPLAY On	P1	Trigger Immediate	T2
25 μ s DE-EMPHASIS	P2	Trigger with Settling	T3
50 μ s DE-EMPHASIS	P3	Hexadecimal A	X0
75 μ s DE-EMPHASIS	P4	Hexadecimal B	X1
750 μ s DE-EMPHASIS	P5	Hexadecimal C	X2
		Hexadecimal D	X3
		Hexadecimal E	X4
		Hexadecimal F	X5
		ZERO	ZR

IF Gain (Special Function 9)

Description

The Measuring Receiver uses an internal IF Amplifier/Filter to provide highly accurate 10 dB steps of gain over a 60 dB range (using the 455 kHz IF). The gain steps are automatically inserted when making Synchronous or Average Tuned RF Level measurements. (Refer to Tuned RF Level.) For any other measurements, the IF gain is automatically set to 0 dB of gain.

The IF gain can be manually set using Special Function 9.

Procedure

To manually set the IF gain, or to re-enter the automatic selection mode, key in the corresponding Special Function code; then press the SPCL key.

IF Gain (dB)	Special Function Code	Program Code ◀HP-IB▶
Automatic Selection	9.0 SPCL	9.0SP
0	9.1 SPCL	9.1SP
10	9.2 SPCL	9.2SP
20	9.3 SPCL	9.3SP
30	9.4 SPCL	9.4SP
40	9.5 SPCL	9.5SP
50	9.6 SPCL	9.6SP
60	9.7 SPCL	9.7SP

Program Codes

All HP-IB codes for selecting IF gain ranges are provided in "Procedures".

Indications

Display: As the numeric code is entered, it appears on the display. When the SPCL key is pressed, the display returns to the measurement previously selected.

Front Panel: The LED within the SPCL key lights (unless 9.0 SPCL is entered.)



Table 3-3. Commonly Used Code Conversions

ASCII	Binary	Octal	Decimal	Hexa-decimal
NUL	00 000 000	000	0	00
SOH	00 000 001	001	1	01
STX	00 000 010	002	2	02
ETX	00 000 011	003	3	03
EOT	00 000 100	004	4	04
ENQ	00 000 101	005	5	05
ACK	00 000 110	006	6	06
BEL	00 000 111	007	7	07
BS	00 001 000	010	8	08
HT	00 001 001	011	9	09
LF	00 001 010	012	10	0A
VT	00 001 011	013	11	0B
FF	00 001 100	014	12	0C
CR	00 001 101	015	13	0D
SO	00 001 110	016	14	0E
SI	00 001 111	017	15	0F
DLE	00 010 000	020	16	10
DC1	00 010 001	021	17	11
DC2	00 010 010	022	18	12
DC3	00 010 011	023	19	13
DC4	00 010 100	024	20	14
NAK	00 010 101	025	21	15
SYN	00 010 110	026	22	16
ETB	00 010 111	027	23	17
CAN	00 011 000	030	24	18
EM	00 011 001	031	25	19
SUB	00 011 010	032	26	1A
ESC	00 011 011	033	27	1B
FS	00 011 100	034	28	1C
GS	00 011 101	035	29	1D
RS	00 011 110	036	30	1E
US	00 011 111	037	31	1F
SP	00 100 000	040	32	20
!	00 100 001	041	33	21
"	00 100 010	042	34	22
#	00 100 011	043	35	23
\$	00 100 100	044	36	24
%	00 100 101	045	37	25
&	00 100 110	046	38	26
'	00 100 111	047	39	27
(00 101 000	050	40	28
)	00 101 001	051	41	29
*	00 101 010	052	42	2A
+	00 101 011	053	43	2B
,	00 101 100	054	44	2C
-	00 101 101	055	45	2D
.	00 101 110	056	46	2E
/	00 101 111	057	47	2F
0	00 110 000	060	48	30
1	00 110 001	061	49	31
2	00 110 010	062	50	32
3	00 110 011	063	51	33
4	00 110 100	064	52	34
5	00 110 101	065	53	35
6	00 110 110	066	54	36
7	00 110 111	067	55	37
8	00 111 000	070	56	38
9	00 111 001	071	57	39
:	00 111 010	072	58	3A
;	00 111 011	073	59	3B
<	00 111 100	074	60	3C
=	00 111 101	075	61	3D
>	00 111 110	076	62	3E
?	00 111 111	077	63	3F

ASCII	Binary	Octal	Decimal	Hexa-decimal
@	01 000 000	100	64	40
A	01 000 001	101	65	41
B	01 000 010	102	66	42
C	01 000 011	103	67	43
D	01 000 100	104	68	44
E	01 000 101	105	69	45
F	01 000 110	106	70	46
G	01 000 111	107	71	47
H	01 001 000	110	72	48
I	01 001 001	111	73	49
J	01 001 010	112	74	4A
K	01 001 011	113	75	4B
L	01 001 100	114	76	4C
M	01 001 101	115	77	4D
N	01 001 110	116	78	4E
O	01 001 111	117	79	4F
P	01 010 000	120	80	50
Q	01 010 001	121	81	51
R	01 010 010	122	82	52
S	01 010 011	123	83	53
T	01 010 100	124	84	54
U	01 010 101	125	85	55
V	01 010 110	126	86	56
W	01 010 111	127	87	57
X	01 011 000	130	88	58
Y	01 011 001	131	89	59
Z	01 011 010	132	90	5A
[01 011 011	133	91	5B
\	01 011 100	134	92	5C
]	01 011 101	135	93	5D
^	01 011 110	136	94	5E
_	01 011 111	137	95	5F
`	01 100 000	140	96	60
a	01 100 001	141	97	61
b	01 100 010	142	98	62
c	01 100 011	143	99	63
d	01 100 100	144	100	64
e	01 100 101	145	101	65
f	01 100 110	146	102	66
g	01 100 111	147	103	67
h	01 101 000	150	104	68
i	01 101 001	151	105	69
j	01 101 010	152	106	6A
k	01 101 011	153	107	6B
l	01 101 100	154	108	6C
m	01 101 101	155	109	6D
n	01 101 110	156	110	6E
o	01 101 111	157	111	6F
p	01 110 000	160	112	70
q	01 110 001	161	113	71
r	01 110 010	162	114	72
s	01 110 011	163	115	73
t	01 110 100	164	116	74
u	01 110 101	165	117	75
v	01 110 110	166	118	76
w	01 110 111	167	119	77
x	01 111 000	170	120	78
y	01 111 001	171	121	79
z	01 111 010	172	122	7A
{	01 111 011	173	123	7B
	01 111 100	174	124	7C
}	01 111 101	175	125	7D
~	01 111 110	176	126	7E
DEL	01 111 111	177	127	7F

*The ASCII code set is used extensively throughout this manual, for example, in the tables of HP-IB Program Codes. The shaded ASCII codes represent HP-IB addresses when the ATN bus line is 1 (L=1).

HP-IB Address (Cont'd) (Special Function 21)

Indications (cont'd)

Display: The display shows a binary number of the form AAAAA.TLS (cont'd) where AAAAA is the HP-IB address in binary, and T, L, and S have the meaning indicated in the following table:

	T	L	S
0	Not Talk Only	Not Listen Only	Not Requesting Service
1	Talk Only	Listen Only	Requesting Service

If T and L are both 1, the instrument is set to talk only (talk overrides listen). If all the A digits are set to 1 and T is 1, the instrument will talk status only (i.e., output the status byte only). (If digits AAAAA.TL are 1, but S is 0, the HP-IB board is not installed.)

Front Panel: The LED within the SPCL key lights and all measurement key lights and annunciators turn off.

Example

If 01110.001 is displayed, then the HP-IB address is 01110 in binary, or 14 in decimal. In ASCII, the talk address is N, and the listen address is . (decimal point). The instrument is not set to talk or listen only, but it is issuing a service request (setting the SRQ control line true).

HP-IB Program Code

SPCL = SP

Comments

The HP-IB address display is continuously updated. When the switch setting is changed, the result is immediately visible on the display.

For information on setting the HP-IB address of the Measuring Receiver, refer to Section II of this manual.

The factory-set address is decimal 14.

Related Functions

Remote Operation, Hewlett-Packard Interface Bus (Section III)
Special Functions

Introduction to Detailed Operating Instructions

The Detailed Operating Instructions describe most of the functions that can be accessed by the user.

Title: Lists the main function to be discussed as well as any related front-panel keys or special functions that won't be described in any other instructions.

Description: Describes the function.

Procedure: Enables the user to perform the measurement or function that is explained in the "Description". Possible malfunctions and operator errors might be discussed in "Comments".

Example: Describes the necessary steps required to accomplish one of the more complicated functions discussed in the procedure.

Indications: Describes the expected response of the instrument when the procedure is performed; which annunciators will light in the display and which LEDs within the keys will light.

Measurement Technique: Describes the circuit operation that enables the instrument to make the measurement described in "Description".

Comments: Describes any miscellaneous information; any discrepancies in the instrument's performance during a measurement, or those features that can be used to extend the normal capability of the function.

HP-IB Address (Special Function 21)

Description

The Measuring Receiver's present HP-IB address can be displayed using Special Function 21. The binary code displays the HP-IB address, whether the instrument is set to talk only or to listen only, and whether it is currently issuing a service request.

The HP-IB address display does not time out, but it can be cleared by pressing any key (except the LOCAL, S (shift), Blue Key, or number keys).

Procedure

To display the HP-IB address, key in the code 21.0 on the numeric keys, then press the SPCL key. To clear the display, press the CLEAR key. A list of allowable HP-IB addresses is provided in the following table:

Allowable HP-IB Address Codes

Address Swtiches					Talk Address Character	Listen Address Character	Decimal Equivalent	Address Swtiches					Talk Address Character	Listen Address Character	Decimal Equivalent
A5	A4	A3	A2	A1				A5	A4	A3	A2	A1			
0	0	0	0	0	@	SP	0	1	0	0	0	0	P	0	16
0	0	0	0	1	A	!	1	1	0	0	0	1	Q	1	17
0	0	0	1	0	B	"	2	1	0	0	1	0	R	2	18
0	0	0	1	1	C	#	3	1	0	0	1	1	S	3	19
0	0	1	0	0	D	\$	4	1	0	1	0	0	T	4	20
0	0	1	0	1	E	%	5	1	0	1	0	1	U	5	21
0	0	1	1	0	F	&	6	1	0	1	1	0	V	6	22
0	0	1	1	1	G	'	7	1	0	1	1	1	W	7	23
0	1	0	0	0	H	(8	1	1	0	0	0	X	8	24
0	1	0	0	1	I)	9	1	1	0	0	1	Y	9	25
0	1	0	1	0	J	*	10	1	1	0	1	0	Z	:	26
0	1	0	1	1	K	+	11	1	1	0	1	1	[;	27
0	1	1	0	0	L	,	12	1	1	0	1	0	\	<	28
0	1	1	0	1	M	-	13	1	1	1	0	0]	=	29
0	1	1	1	0	N	.	14	1	1	1	1	0	^	>	30
0	1	1	1	1	O	/	15	1	1	1	1	1	Invalid	Invalid	31

Indications

Display: As the numeric code is entered, it appears on the display. When the SPCL key is pressed, the HP-IB code is displayed.

AM
(Includes Special Function 2)

Description

The AM key enables the Measuring Receiver to measure the AM depth of the tuned RF input signal. Special Function 2 enables the instrument to set limits on the range of AM depth that can be measured.

The demodulated AM is present at MODULATION OUTPUT/AUDIO INPUT (unless AUDIO INPUT has been selected). The demodulated AM is usually present at the rear-panel AM OUTPUT connector. (Refer to AM Output.)

AM measurements are specified for rates from 20 Hz to 10 kHz for carriers 10 MHz and below (or whenever the 455 kHz IF is used) and 20 Hz to 100 kHz for carriers from 10 to 1300 MHz (1.5 MHz IF only). The corresponding 3 dB audio bandwidths are 0.5 Hz to 15 kHz for carriers 10 MHz and below (or with the 455 kHz IF) and 0.5 Hz to 260 kHz for carriers from 10 to 1300 MHz (1.5 MHz IF only). Modulation depths to 99% can be measured.

The demodulated signal's frequency and distortion can also be characterized. (Refer to Audio Distortion and Level and Audio Frequency.)

Procedure

To make an AM measurement, first tune the instrument to the input signal. (Refer to RF Frequency Tuning or press AUTOMATIC OPERATION). Press the AM key.

Select an audio detector: PEAK+, PEAK-, or AVG. (The RMS detector, selected by pressing the Blue Key and the RMS key, is not quite as accurate in measuring AM and is usually only used for audio distortion measurements.)

The following table lists the different measurement range limits that can be selected with Special Function 2:

Modulation Range Peak± (%)	Detector Selected	Special Function Code	Program Code ◀ HP-1B ▶	Display Resolution (%)	MODULATION OUTPUT Sensitivity (Vac/% AM)
Automatic Selection		2.0 SPCL	2.0SP	Automatic Selection	
≤4	RMS	2.4 SPCL	2.4SP	0.001	1
≤40	Pk, Avg	2.4 SPCL	2.4SP	0.01	0.1
≤40	Pk, Avg, RMS	2.1 SPCL	2.1SP	0.01	0.1
≤100	Pk, Avg, RMS	2.2 SPCL or 2.3 SPCL	2.2SP or 2.3SP	0.1	0.01

Frequency Offset Control (Cont'd) (Includes Special Function 27)

Comments

The Measuring Receiver assumes the condition:

Displayed Microwave Frequency = External LO - Measured RF; unless manually tuned with a microwave frequency entry that is greater than the external LO.

The instrument will then assume the condition:

Displayed Microwave Frequency = External LO + Measured RF; until manually tuned with a microwave frequency entry less than the external LO.

If the entered LO frequency and microwave input frequency ever differ by more than 1300 MHz (or less than 0.15 MHz), an out-of-range error is displayed (Error 10).

The automatic tune function does not work over the new measurement range of 0 to 42 GHz but can only tune across 1300 MHz greater than (or less than) the external LO.

Manual tuning uses the LO polarity required depending on whether the microwave input is less than or greater than the external LO frequency. Automatic tuning uses whatever LO polarity (positive or negative) that was in effect last (at power-up, the polarity is positive).

When FM or ϕ M measurements are made, the Peak+ and Peak- functions can be interpreted as being reversed whenever the external LO frequency is greater than the microwave input frequency.

Special Function 22 can enable a service request to be pulled whenever the Frequency Offset mode changes state (bit weight 16), when the tuned frequency is changed, or when Special Function 27.0, 1, or 3 is used to enter or exit the mode. (Refer to Service Request Condition.)

TTL Output:

When the Measuring Receiver is in the Frequency Offset mode, the TTL output is dependent upon the value entered as the external LO frequency. If the entered value is zero, the TTL output is 0V nominal. If the LO is greater than 0, but less than 18 GHz, the nominal output is 5V. For LO frequency values greater than 18 GHz, the TTL output is 3V nominal. When not in Frequency Offset mode, the output is 0V.

Related Functions

RF Frequency Tuning
Special Functions

AM (Cont'd)
(Includes Special Function 2)

Procedure (cont'd)

To filter the demodulated signal, press the appropriate filter keys (refer to Audio Filters).

If AM depth is to be displayed relative to a reference, enter the value as a ratio reference using the RATIO key. (Refer to Ratio.)

Example

To measure the positive peak AM depth of a signal in a 50 Hz to 15 kHz demodulated signal bandwidth:

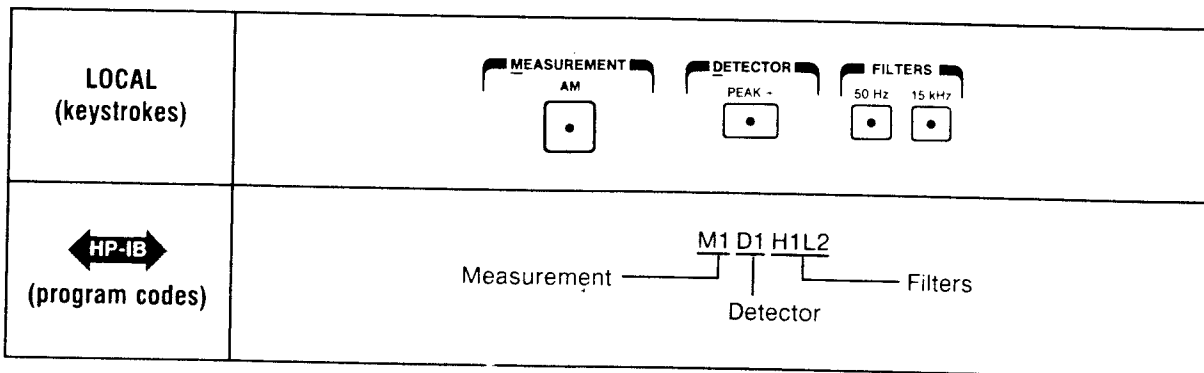

HP-IB Program Codes

All HP-IB codes for changing the limits of the modulation-depth measurements are provided in "Procedures".

AM = M1
SPCL = SP

Indications

Display: When the AM key is pressed, the measured AM depth is displayed. The % annunciator is also displayed.

Front Panel: The LEDs within the selected functions light.

Measurement Technique

The AM Demodulator measures AM as a ratio of the demodulated audio signal level to the average tuned carrier level. An automatic level control (ALC) loop within the AM Demodulator holds the carrier level constant so that the percent AM is proportional to the peak amplitude of the demodulated audio output. This audio output is then filtered, audio detected, and displayed as % AM. The demodulated AM is available at MODULATION OUTPUT/AUDIO INPUT (unless AUDIO INPUT is selected).

Frequency Offset Control (Cont'd)
(Includes Special Function 27)

Procedures (cont'd)

Manually tune to the microwave input frequency by pressing the appropriate numeric keys followed by the MHz key.

Perform any normal instrument measurement; press the Blue Key and the DISPLAY FREQ key to display the microwave input frequency.

HP-IB Program Codes

All HP-IB codes for manipulating the frequency offset control using Special Function 27 are provided in "Procedures".

DISPLAY FREQ = FR
MHz = MZ

Indications

Display: As the numeric code is entered, it appears on the display. When the SPCL key is pressed, the display returns to the measurement previously selected.

When 27.0 SPCL is keyed, the f OFS annunciator turns off.
When 27.1 SPCL is keyed, the f OFS annunciator turns on.
When 27.3 SPCL is keyed, and the external LO entry is completed, the f OFS annunciator turns on.

When 27.2 SPCL is keyed, the value of the entered external LO frequency is displayed. This value is timed out.

Front Panel: Special Function 27.2 lights the SPCL key.
Special Function 27.3 lights the SPCL key (after MHz entry).

Measurement Technique

The external LO mixes with the microwave input signal to create a difference frequency. The microwave input is ± 1300 MHz (the normal frequency range of the instrument) from the external LO frequency. If the microwave input frequency is lower than the external LO, the Measuring Receiver uses the LO minus the microwave input, and the sign of the external LO is positive. If the microwave input frequency is greater than the external LO, the Measuring Receiver uses the LO plus the microwave input and the sign of the external LO is negative. The external LO frequency at the mixer port and the LO frequency that was entered into the Measuring Receiver with Special Function 27.3 must be the same value.

Whenever a new external LO or a new microwave frequency is entered, the Measuring Receiver retunes as if the indicated change was physically made externally.

AM (Cont'd)
(Includes Special Function 2)

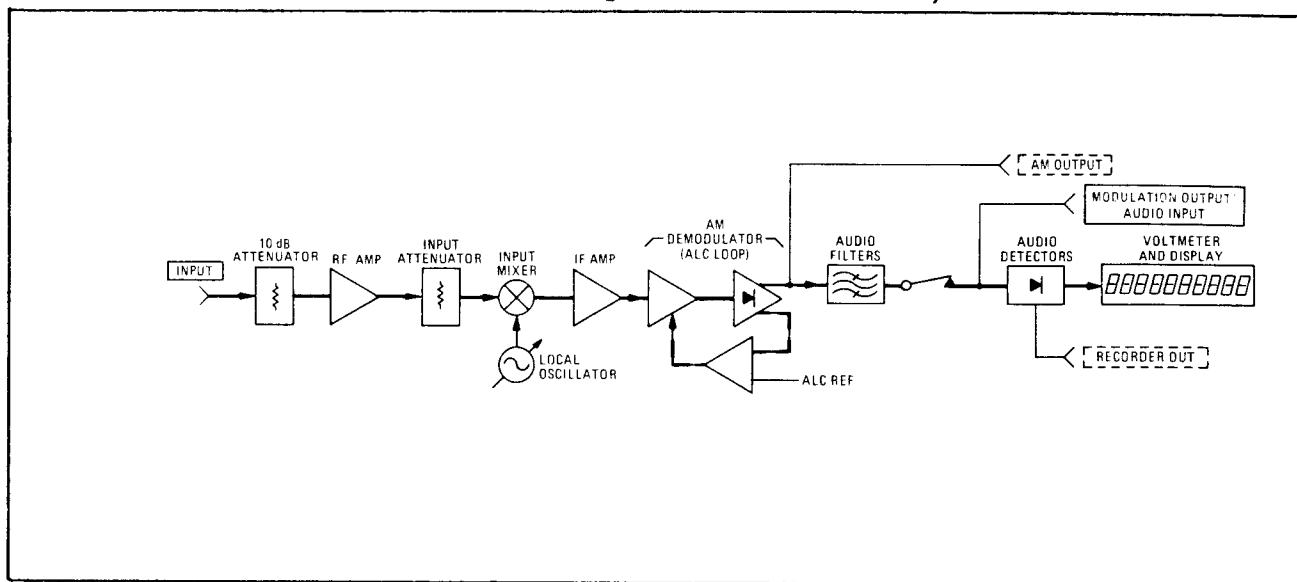

AM Measurement Block Diagram

Comments

The PEAK+ detector always detects the peak of the carrier envelope while the PEAK- detector always detects the trough. The PEAK $\pm/2$ detector sums the peak and the trough and divides the total by two to provide an average peak value. (This value should not be confused with a detected average value.)

The routine which automatically selects the modulation range contains a region of overlap between 35 and 40% AM (peak detected). When using the average detector, ranging occurs with lower modulation levels displayed. If the modulation level is reduced from above 40% into this overlap region, only 0.1% resolution might be displayed although 0.01% resolution is available. To display the increased resolution, press the AM key a second time. To set the instrument to a selected modulation range, refer to Audio Range.

When operating above 2.5 MHz while using the 455 kHz IF, the upper limit of the modulation rate is that of the >20 kHz LP FILTER. The 15 kHz LP FILTER is automatically selected when operating below 10 MHz or whenever the 455 kHz IF is selected. However, this filter may be overridden by selecting another LP FILTER. The lower limit of the modulation rate is determined by the ALC response time selected. (Refer to AM ALC Response Time.)

The signal at AM OUTPUT is inverted for all carrier frequencies.

AM conditions that cause the carrier signal to disappear (such as 100% AM or pulse modulation) will cause inaccuracies in measurement of FM, ϕ M, or input frequency, or they could cause Error 05 (FM squelched) to be displayed when these measurements are selected.

Frequency Offset Control (Special Function 27)

Description

Frequency Offset Control can be used with an external LO and an external mixer to enable the Measuring Receiver to make measurements on microwave input frequencies to 42 GHz. All normal instrument measurements can be made on this input signal. For most accurate measurements, the external LO should be a relatively pure signal from a synthesized signal source (such as the HP 8340A, 8671A, 8672A, or 8673A).

The Measuring Receiver uses Special Function 27 to enter and display the frequency of the external LO. This Special Function is also used to enable the Frequency Offset mode.

When in Frequency Offset mode, the RF Power function has available a separate table of frequency/calibration factor entries. Frequency entries can range from 0 to 42 GHz. (Refer to RF Power Calibration Factors.)

Procedures

To make measurements on microwave input frequencies, connect a synthesized, high-frequency signal to the LO input connector of an external mixer. Also, connect the microwave input signal to the other input of the mixer. Connect the output of the mixer to the RF INPUT connector and/or the SENSOR input connector of the Measuring Receiver.

Perform the actions required with the Special Functions in the following table:

Action Regarding Frequency Offset Control	Special Function Code	Program Code ◀ HP-IB ▶
Exit Frequency Offset Mode	27.0 SPCL	27.0SP
Re-enter Frequency Offset Mode	27.1 SPCL	27.1SP
Display the External LO Frequency	27.2 SPCL	27.2SP
Enter and Enable the LO Frequency*	27.3 SPCL	27.3SP
*After Special Function 27.3 is entered, enter the frequency of the LO (in MHz). Frequencies from 0 to 40700 MHz can be entered.		

AM (Cont'd)
(Includes Special Function 2)

Related Functions

AM Output
AM ALC Response Time
Audio Detectors
Audio Filters
Audio Range
Ratio
Residual Noise Effects

FM Output (Cont'd)

Example

A 2 MHz unmodulated signal is applied to the RF INPUT. A dc voltmeter connected to FM OUTPUT measures +3.89 Vdc. When the carrier is set to 1 MHz, -2.272 Vdc is measured. The FM sensitivity is:

$$(3.890) - (-2.272) = 6.162 \text{ V/MHz} = 6.162 \text{ mV/kHz}$$

Block Diagram

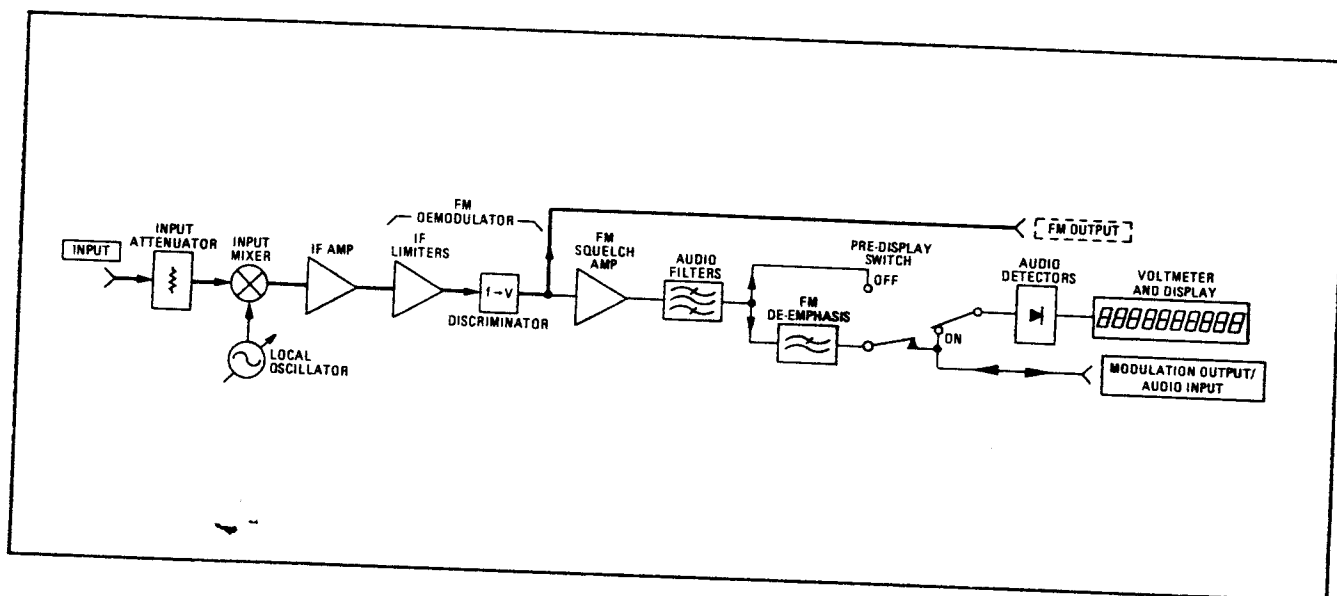

FM OUTPUT Block Diagram

Comments

FM OUTPUT is unsquelched and also contains a significant component at twice the IF frequency which is greatest when operating at a carrier of 150 kHz.

Note that the sense of the ac output component (corresponding to the demodulated FM) is inverted for carriers above 2.5 MHz.

When RF Level measurements are made, automatic RF input attenuation and gain overrides any manual settings that might have been selected with Special Function 1. The selected attenuation could degrade the accuracy of measurements made on the FM OUTPUT signal.

Related Functions

AM Output

FM

RF Frequency Error

AM ALC Response Time (Special Function 6)

Description

The Measuring Receiver normally uses a slow-responding AM automatic level control (ALC) circuit, allowing AM rates as low as 20 Hz to pass unaffected by the leveling loop. (Refer to the figure in AM, "AM Measurement Block Diagram".)

Select a fast ALC response time to speed up the measurement settling time required for varying carrier levels. (The faster ALC response time affects AM accuracy at rates less than 1 kHz.)

Disable the ALC and use the rear-panel AM OUTPUT to measure very low modulation rates. (Refer to AM Output.)

Procedure

The instrument normally operates with a slow AM ALC response time. To change the response time, or to disable the ALC, enter the corresponding Special Function code, then press the SPCL key:

AM ALC Response	Special Function Code	Program Code ◀HP-IB▶
Slow ALC (AM rates >20 Hz)	6.0 SPCL	6.0SP
Fast ALC (AM rates >1 kHz)	6.1 SPCL	6.1SP
ALC off	6.2 SPCL	6.2SP

◀HP-IB▶ Program Codes

For HP-IB codes, refer to "Procedure".

Indications

Display: As the numeric code is entered, it appears on the display. When the SPCL key is pressed, the display returns to the measurement previously selected.

Front-panel: The LED within the SPCL key lights (unless 6.0 SPCL is entered).

FM Output

CAUTION

Do not apply greater than 10 V_{peak} (ac + dc) into the FM OUTPUT connector or damage to the instrument could result.

Description

The rear-panel FM OUTPUT (dc-coupled, 10 kohm output impedance) provides an auxiliary output for the FM that is demodulated from the signal at the RF INPUT. This output is used to monitor FM when displaying other measurements (such as AM, ϕ M, or audio signals) or when the modulation rate is very low.

The output signal comprises a dc voltage, related to the detected IF frequency, and an ac voltage (bandwidth 16 kHz, 1 pole) proportional to the FM deviation.

With the input signal centered in the IF, the nominal dc offset voltage at FM OUTPUT is approximately 0.8 Vdc for the 1.5 MHz IF and -5.6 Vdc for the 455 kHz IF. The FM sensitivity is typically 6V/MHz or 6 mV/kHz. The dc voltage at FM OUTPUT can be calculated as follows:

$$V_{dc} = V_{off} - \frac{(K) (FREQ ERROR)}{1000}$$

Where,

- V_{dc} = the dc voltage at FM OUTPUT in volts,
- V_{off} = the dc offset voltage for the IF used in volts,
- K = the FM sensitivity in mV/kHz, or V/MHz, and
- FREQ ERROR = the kHz error displayed when the FREQ ERROR key is pressed.

Measure V_{off} when the frequency error is 0 kHz. The sensitivity can be measured using the following procedure:

Procedure

To characterize the sensitivity of the FM OUTPUT, apply an unmodulated 2 MHz carrier at the RF INPUT (use the 1.5 MHz IF selected with Special Function 3 described in Filters, RF and IF). Measure the dc voltage at the output with a dc voltmeter. Move the carrier to 1 MHz and again note the dc voltage. The FM sensitivity (K) is:

$$(V_{dc} @ 2 \text{ MHz}) - (V_{dc} @ 1 \text{ MHz}) = V/\text{MHz or mV/kHz}$$

AM ALC Response Time (Cont'd)
(Special Function 6)

Comments

When the instrument is first turned on, or when AUTOMATIC OPERATION or INSTR PRESET is pressed, the slow ALC response is selected.

The displayed modulation depth is incorrect when the ALC is disabled unless the IF level is 100%. (Refer to IF Level.)

Related Functions

AM

AM Output

IF Level

Special Functions

FM De-emphasis (Cont'd)

Comments (cont'd)

When 750 us de-emphasis is selected, the FM sensitivity is increased by a factor of ten. The range of deviation measurements is restricted to 40 kHz peak deviation or less after de-emphasis. The modulation ranges are ten times more sensitive (the most sensitive range is 0.4 kHz) to provide greater resolution for measuring low deviation FM.

Related Functions

FM
Modulation Output
Recorder Output

AM Calibration
(Includes the CALIBRATE, SAVE CAL, and % CAL FACTOR keys,
and Special Functions 13 and 16)

Description

The accuracy of the Measuring Receiver's AM demodulator can be checked with the internal AM calibrator. The calibration process generates a calibration factor that indicates the AM measurement error (within the accuracy limits of the calibrator). The calibration factor can then be enabled to automatically correct the known AM error in subsequent measurements (the SAVE CAL key or Special Function 16). With the calibration factor enabled, AM measurements can be made with an accuracy typically better than 0.5%. The calibration factor can be enabled, disabled, or displayed at any time.

Other instruments in the HP 8901 and 8902 RF signal analyzer family can be calibrated or cross checked with the Measuring Receiver's AM calibrator using Special Function 13.

Procedures

Self-calibration. To determine the measurement error of the Measuring Receiver's AM demodulation circuits, first allow at least a half-hour continuous operation before calibration, then perform the following steps:

1. Connect the CALIBRATION AM/FM OUTPUT to the RF INPUT with a 50 ohm cable (or a sensor module with an internal switch such as the HP 11722A), and select AM.
2. Press the CALIBRATE key. After several seconds, the AM calibration factor will be displayed in % and stored.

The instrument displays 100.00% if no error is measured. A display of 100.17% means the Measuring Receiver is reading 0.17% high. As long as the CALIBRATE key light is on and the cable is connected, calibration continues and the AM calibration factor is updated approximately every 17 seconds. To turn off the calibrator press the CALIBRATE key or any MEASUREMENT key.

NOTE

For optimum accuracy, the instrument should be continuously operating for at least one half hour before calibration is performed. In addition, the first two AM Calibration Factors received after instrument power-up should not be used even if the instrument is already warm, since the circuits in the audio chain may not be fully settled.

FM De-emphasis (Cont'd)

Example

To measure the positive peak FM deviation of a carrier with 750 us de-emphasis inserted before the deviation measurement:

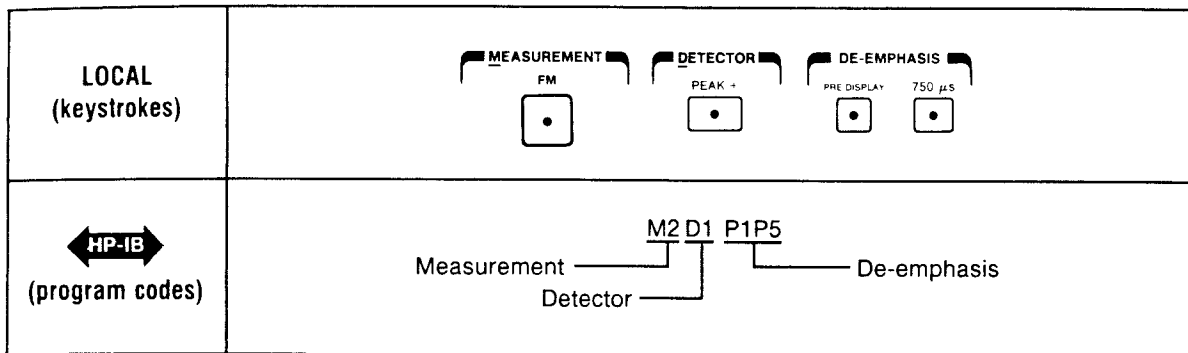

Program Codes

FM De-emphasis		
Time Constant (μ s)	PRE DISPLAY On	PRE DISPLAY Off
Filters off	P0P1	P0
25	P1P2	P0P2
50	P1P3	P0P3
75	P1P4	P0P4
750	P1P5	P0P5

Indications

Front Panel: When a de-emphasized signal is available at MODULATION OUTPUT/AUDIO INPUT, the LED within the selected filter's key lights. If the de-emphasized signal is being displayed, the light within the PRE DISPLAY key lights.

Comments

Until they are turned off, the de-emphasis filters are always active when demodulated FM is present at MODULATION OUTPUT/AUDIO INPUT.

AM Calibration (Cont'd)
(Includes the CALIBRATE, SAVE CAL, and % CAL FACTOR keys,
and Special Functions 13 and 16)

Procedures (cont'd)

Correcting Measurements with the AM Calibration Factor. Once a calibration factor has been determined, the instrument retains that value in its non-volatile memory. (Refer to Instrument Preset.) This factor may be enabled to automatically correct AM measurements. The calibration factor can also be disabled or displayed.

Enter the appropriate front-panel key or Special Function code for the desired action described in the following table:

Action: AM Calibration Factor	Measurement Mode	Front-Panel Key or Special Function Code	Program Code 
Disable	Any	16.0 SPCL	16.0SP
Enable	AM (From CALIBRATE mode)	(Blue Key) SAVE CAL	SC
	Any	16.1 SPCL	16.1SP
Display	AM	(Blue Key) % CAL FACTOR*	CF
	Any	16.2 SPCL	16.2SP

* The % CAL FACTOR key displays the status of the calibration factor: The factor is enabled if the value of the calibration factor is displayed, with 0.01% resolution. The factor is disabled if 100% is displayed. (Note the resolution of 1%. A display of 100.00% would be a true, calibration factor reading.)

Calibrating or Cross Checking Another HP 8901 or 8902 RF Signal Analyzer. To compute an AM calibration factor for another RF signal analyzer that has no internal calibrator, or that has an internal calibrator that is to be cross checked, use the Measuring Receiver and its calibrator as follows:

1. Connect the Measuring Receiver's CALIBRATION AM/FM OUTPUT to the RF input of the RF signal analyzer.
2. Key 13.0 SPCL into the Measuring Receiver. Record the value that appears on the display. This is the computed, calibrated, peak AM depth (excluding noise).
3. Key 13.1 SPCL into both instruments. Record the value that appears on the display of the RF signal analyzer. (If display jitter makes readings difficult, key 5.1 SPCL.) The displayed value is the weighted, peak, residual AM depth of the calibrator's unmodulated output as demodulated by the RF signal analyzer.

FM De-Emphasis

Description

The de-emphasis filters compensate for pre-emphasis on FM signals. (Pre-emphasis is a 6 dB per octave, high-frequency boost given to the audio signal before modulating the carrier.) The 3 dB corner frequency, f_0 , is commonly expressed as a time constant τ_0 , where $f_0 = \frac{1}{2\pi\tau_0}$.

When selected, the filters are inserted in the audio signal path following the modulation filters. They always affect the output signal at MODULATION OUTPUT/AUDIO INPUT and can be placed before the audio detector and display. (Refer to the block diagram in FM.) De-emphasis has no effect on the rear-panel FM OUTPUT. The 3 dB frequency of these filters (typically accurate to $\pm 3\%$) are provided in the following table:

FM De-emphasis	
Time Constant (μs)	3 dB Frequency (Hz)
25	6366
50	3183
75	2122
750	212.2

Procedure

To de-emphasize the demodulated FM, press the key corresponding to the desired time constant. The displayed deviation is measured before de-emphasis is performed (with the de-emphasized signal available at MODULATION OUTPUT/AUDIO INPUT unless AUDIO INPUT is selected). To display the deviation after it is de-emphasized, press the PRE DISPLAY key.

To change the de-emphasis time constant, press the key corresponding to the new time constant desired.

In local operation, to turn off one of the de-emphasis functions, press the lighted key a second time. In remote operation, turn filters off with code P0. (HP-IB code P0 also turns off the PRE DISPLAY function.)

AM Calibration (Cont'd)
 (Includes the CALIBRATE, SAVE CAL, and % CAL FACTOR keys,
 and Special Functions 13 and 16)

Procedures (cont'd)

4. Key 13.2 SPCL into both instruments. Record the value that appears on the display on the RF signal analyzer. This value is the demodulated, positive, peak AM depth of the calibrator's modulated output. (If display jitter makes readings difficult, key 5.1 SPCL.)
5. On the RF signal analyzer, press PEAK-. Note the value displayed on the RF signal analyzer. If the difference between the results of steps 4 and 5 is 3 counts or less in the least significant digit, an average between the two need not be computed; use the result from step 4. If the difference between the two results is greater than 3 counts in the least significant digit, compute the average as follows:

$$(13.2 \text{ result}) = \frac{(\text{result of step 4}) + 2(\text{result of step 5})}{3}$$

6. Compute the AM calibration factor of the RF signal analyzer as follows:

$$\text{AM Calibration Factor (\%)} = 100 \times \frac{(13.2 \text{ result}) - (13.1 \text{ result})}{(13.0 \text{ result})}$$

7. To use this AM calibration factor to correct AM measurements made with the RF signal analyzer, enter the value as a ratio reference and use the Ratio function in the RF signal analyzer.

The Special Function codes are summarized in the table below:

Function	Special Function Code	Program Code 
Display computed peak AM	13.0 SPCL	13.0SP
Display demodulated peak residual AM	13.1 SPCL	13.1SP
Display demodulated peak AM	13.2 SPCL	13.2 SP

FM Calibration (Cont'd)
 (Includes the CALIBRATE, SAVE CAL, and % CAL FACTOR keys,
 and Special Functions 12 and 17)

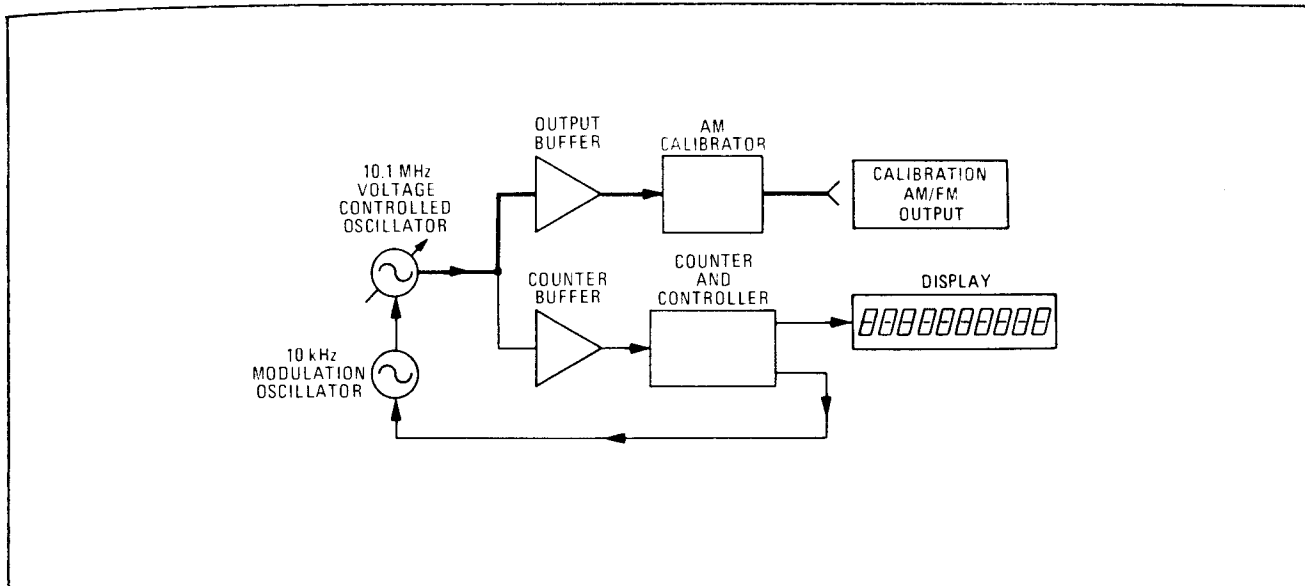

Simplified Block Diagram of the FM Calibrator

Comments

If the instrument's non-volatile memory is erased, 100.00% is used as the default calibration factor.

Whenever FM calibration is performed, the FM calibration factor stored in the instrument is updated with the new factor.

Pressing the CALIBRATE key cancels all Special Functions.

The modulation waveform of the FM Calibrator is rounded squarewave. The RF signal analyzer that uses it as a calibration standard must have demodulation and audio processing circuits which preserve the full fidelity of the waveform.

When used to calibrate an RF signal analyzer, Special Functions 12.1 and 12.2 set the FM deviation range to that of 0 to 40 kHz (Special Function 2.2). Upon exiting the FM Calibrator Special Function, the audio ranging is not returned to automatic but remains fixed (thus leaving the SPCL light on). Key in 2.0 SPCL to return the audio ranging to automatic.

Related Functions

FM
 Ratio
 Residual Noise Effects
 Special Functions

AM Calibration (Cont'd)
 (Includes the CALIBRATE, SAVE CAL, and % CAL FACTOR keys,
 and Special Functions 13 and 16)

HP-IB Program Codes

HP-IB codes for enabling, disabling, or displaying the internal AM calibration factor are provided in "Procedures". The HP-IB codes for the AM Calibrator Special Function used to calibrate an RF signal analyzer are also provided as part of "Procedures".

AM = M1

CALIBRATE on = C1

CALIBRATE off = C0

SPCL = SP

Indications

Self-calibration.

Display: When the CALIBRATE key is pressed, approximately 17 seconds pass during which the instrument configures itself and tunes to the calibrator's signal. The display indicates four dashes (----) and lights the % annunciator. Once the AM calibration factor has been computed, it is displayed. Subsequent updates occur approximately every 17 seconds.

Front Panel: The LEDs within the AM and CALIBRATE keys light. The LEDs within the FILTERS, FM DE-EMPHASIS, DETECTOR, DISPLAY, Blue Key, DISABLE ERROR, and SPCL keys are all disabled.

Correcting Measurements with the AM Calibration Factor (Self-calibrated).

Display: When the calibration factor is enabled, the AM depth measurement is always a corrected measurement.

If 16.2 SPCL is keyed, the value of the calibration factor is displayed.

If % CAL FACTOR is keyed, and the AM calibration factor is enabled, the value of the % AM calibration factor is displayed. If % CAL FACTOR is keyed, and the AM calibration factor is disabled, 100% is displayed. (Note the resolution of 1%.)

The display times out after a few seconds and returns the previous display.

Front Panel: When the instrument displays a calibration factor, the SPCL key lights and all annunciators and other key lights are turned off.

FM Calibration (Cont'd)
 (Includes the CALIBRATE, SAVE CAL, and % CAL FACTOR keys,
 and Special Functions 12 and 17)

Indications (cont'd)

Calibrating Another RF Signal Analyzer.

Display: As the numeric Special Function codes are entered, they appear on the front-panel display. The Measuring Receiver displays the computed FM deviation (Special Function 12.0), but shows two dashes (--) throughout the other measurements.

Front Panel: During these measurements, no measurement keys light, but the LEDs within the SPCL key, the selected DETECTOR key, and the CALIBRATE key of the Measuring Receiver light.

Measurement Technique

When FM is selected and the CALIBRATE key is pressed, a 10.1 MHz voltage controlled oscillator (VCO) within the calibrator is driven to one end of its nominal tuning range. The frequency of the VCO is counted, and the oscillator is driven to the opposite end of its control range where it is counted again. The peak FM deviation is computed from these measurements.

While the VCO is at one end of its range, the residual FM of the calibrator (very low) and the FM Demodulator (more significant) are characterized and weighted. (Refer to Residual Noise Effects.) The VCO is frequency modulated by a 10 kHz modulation oscillator, and the FM demodulator makes another FM measurement. (Both peak detectors are used and the average is computed.) The Measuring Receiver compares the deviation computed from the static frequency measurements with the demodulated FM measured when the VCO is modulated. The accuracy of the internal FM demodulator is computed using the following equation:

$$\text{FM Calibration Factor (\%)} = \frac{\text{Demodulated FM} - \text{Demodulated Residual FM}}{\text{Computed FM}} \times 100$$

AM Calibration (Cont'd)
 (Includes CALIBRATE, SAVE CAL, and % CAL FACTOR keys,
 and Special Function 13 and 16)

Indications (cont'd)

Calibrating Another RF Signal Analyzer.

Display: As the numeric Special Function codes are entered, they appear on the front-panel display. The Measuring Receiver displays the computed AM depth (Special Function 13.0), but shows two dashes (--) throughout the other measurements.

Front Panel: During these measurements, no measurement keys light, but the LEDs within the SPCL key, the selected DETECTOR key, and the CALIBRATE key of the Measuring Receiver light.

Measurement Technique

When AM is selected and the CALIBRATE key is pressed, the FM Calibrator sends an unmodulated 10.1 MHz carrier to the AM Calibrator.

The AM Calibrator contains two identical modulators in parallel (whose outputs are summed). When the calibration operation is initiated, each modulator is turned on and each individual output level is measured via an on-board detector to compute AM depth.

While one of the modulators is on, the residual AM of the calibrator (very low) and the AM demodulator (more significant) are characterized and weighted (refer to Residual Noise Effects). Next, one modulator is left on and the other is toggled on and off at a 10 kHz rate. Since the RF signal is switched between full on and half on, the resultant carrier modulation is very near 33.33%. (The exact depth is derived from the measurements that characterize the individual modulators.) This modulation is then measured by the AM demodulator. (Both peak detectors are used, and their average is computed.)

The Measuring Receiver compares the actual AM (static measurements) with the demodulated AM (toggled measurements) and computes its accuracy error as follows:

$$\text{AM Cal Factor (\%)} = \frac{\text{Demodulated AM} - \text{Demodulated Residual AM}}{\text{Computed AM}} \times 100$$

FM Calibration (Cont'd)
 (Includes the CALIBRATE, SAVE CAL, and % CAL FACTOR keys,
 and Special Functions 12 and 17)

HP-IB Program Codes

The HP-IB codes for enabling, disabling, or displaying the internal FM calibration factor are provided in "Procedures". The HP-IB codes for the FM Calibrator Special Function used to calibrate another RF signal analyzer are also provided as part of "Procedures".

FM = M2
 CALIBRATE on = C1
 CALIBRATE off = C0
 SPCL = SP

Indications

Self-calibration.

Display: When the CALIBRATE key is pressed, approximately 17 seconds pass during which the instrument configures itself and tunes to the calibrator's signal. The display indicates four dashes (----) and lights the % annunciator. Once the FM calibration factor has been computed, it is displayed. Subsequent updates occur approximately every 17 seconds.

Front Panel: The LEDs within the FM and CALIBRATE keys light. The LEDs within the FILTERS, FM DE-EMPHASIS, DETECTOR, DISPLAY, Blue Key, DISABLE ERROR, and SPCL keys are all disabled.

Correcting Measurements with the FM Calibration Factor (Self-calibrated).

Display: When the calibration factor is enabled, the FM deviation measurement is always a corrected measurement.

If 17.2 SPCL is keyed, the value of the calibration factor is displayed.

If % CAL FACTOR is keyed, and the FM calibration factor is enabled, the value of the % FM calibration factor is displayed. If % CAL FACTOR is keyed, and the FM calibration factor is disabled, 100% is displayed. (Note the resolution of 1%.)

The display times out after a few seconds and returns the previous display.

Front Panel: When the instrument displays a calibration factor, the SPCL key lights and all annunciators and other key lights are turned off.

AM Calibration (Cont'd)
 (Includes CALIBRATE, SAVE CAL, and % CAL FACTOR keys,
 and Special Functions 13 and 16)

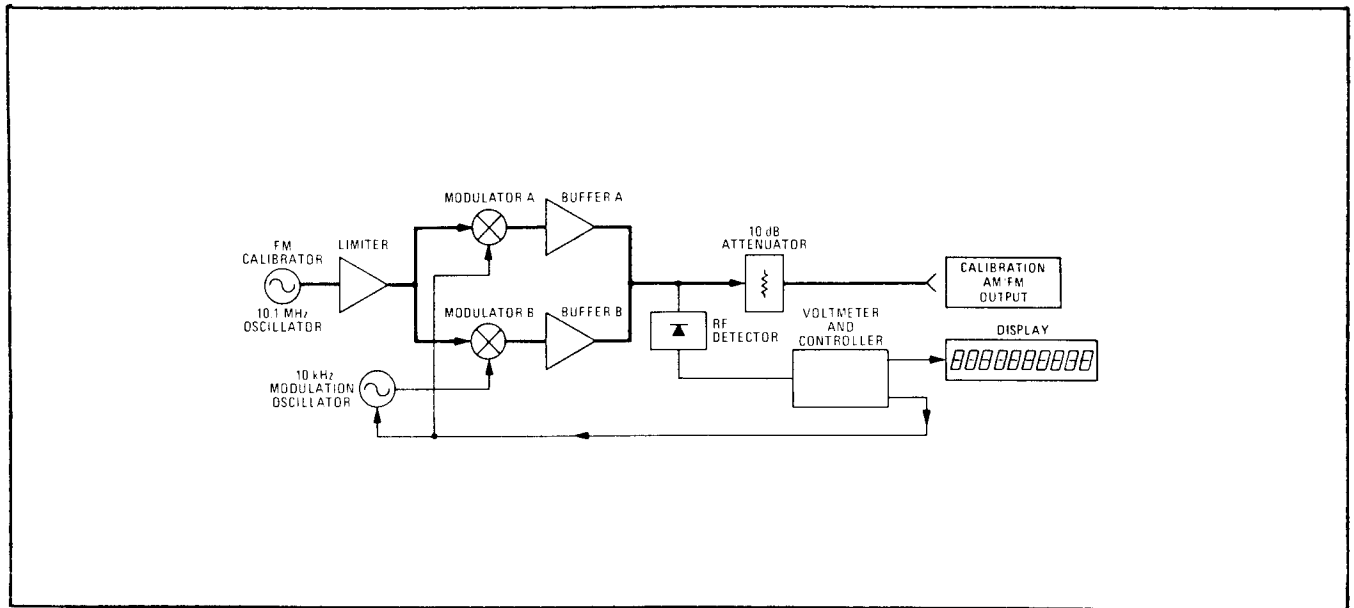

Simplified Block Diagram of the AM Calibrator

Comments

If the instrument's non-volatile memory is erased, 100.00% is used as the default calibration factor.

Whenever AM calibration is performed, the instrument updates the stored AM calibration factor.

Pressing the CALIBRATE key cancels all Special Functions.

The modulation waveform of the AM Calibrator is a rounded squarewave. The RF signal analyzer which uses it as a calibration standard must have demodulation and audio-processing circuits which preserve the full fidelity of the waveform.

When used to calibrate an RF signal analyzer, Special Function 13.1 and 13.2 set the AM modulation range to that of 0 to 100% (Special Function 2.1). Upon exiting the AM Calibrator Special Function, the audio ranging is not returned to automatic but remains fixed (thus leaving the SPCL light on). Key in 2.0 SPCL to return the audio ranging to automatic.

Related Functions

AM
Ratio

Residual Noise Effects
Special Functions

FM Calibration (Cont'd)
 (Includes the CALIBRATE, SAVE CAL, and % CAL FACTOR keys,
 and Special Functions 12 and 17)

Procedures (cont'd)

4. Key 12.2 SPCL into both instruments. Record the value that appears on the display of the RF signal analyzer. (If display jitter makes readings difficult, key 5.1 SPCL.) The displayed value is the demodulated, positive, peak FM deviation of the calibrator's modulated output (including noise).
5. On the RF signal analyzer, press the PEAK- key. Record the value that appears on the display of the RF signal analyzer. If the difference between the readings of steps 4 and 5 is 3 counts or less in the least significant digit, an average between the two need not be computed; use the result from step 4. If the difference between the two readings is greater than 3 counts in the least significant digit, compute the average as follows:

$$(12.2 \text{ result}) = \frac{(\text{result of step 4}) + (\text{result of step 5})}{2}$$

6. Compute the FM calibration factor of the RF signal analyzer as follows:

$$\text{FM Calibration Factor (\%)} = 100 \times \frac{(\text{12.2 result}) - (\text{12.1 result})}{(\text{12.0 result})}$$

7. To use this FM calibration factor to correct FM measurements made with the RF signal analyzer, enter the value as a ratio reference and use the Ratio function in the RF signal analyzer.

The Special Function codes are summarized in the following below:

Function	Special Function Code	Program Code ◀ HP-IB ▶
Display computed peak FM	12.0 SPCL	12.0SP
Display demodulated peak residual FM	12.1 SPCL	12.1SP
Display demodulated peak FM	12.2 SPCL	12.2 SP

AM Output

CAUTION

Do not apply greater than 10V peak (ac+dc) into the AM OUTPUT connector or damage to the instrument may result.

Description

The rear-panel AM OUTPUT (dc coupled, 10 kohm output impedance) provides an auxiliary output for the AM demodulated from the signal at the RF INPUT. This output can be used to monitor AM when displaying other measurements. The output can also be used in conjunction with Special Function 6.2 to measure low AM modulation rates. (Refer to AM ALC Response Time.)

The output signal comprises a dc voltage related to both the detected IF level and an ac voltage (bandwidth 16 kHz, one pole) that is proportional to the AM depth. The dc component contains an offset voltage (V_{off}) which must be subtracted out. The relationship between % AM and the signal levels at AM OUTPUT is:

$$\% \text{ AM} = \frac{V_{pk}}{|V_{dc} - V_{off}|} \times 100\%$$

where:

V_{pk} is the peak of the ac component,
 V_{dc} is the total dc component, and
 V_{off} is the dc offset voltage.

When the AM ALC is on, the dc level at AM OUTPUT is held constant, thus,

$$\% \text{ AM} = K \times V_{pk}, \text{ where } K = \frac{100\%}{|V_{dc} - V_{off}|}$$

When the AM ALC is turned off (Special Function 6.2), the dc voltage at AM OUTPUT varies with the signal level (although the offset remains constant), and the full formula must be used for each measurement.

Procedures

To measure AM depth via AM OUTPUT, first determine the offset voltage:

Press AUTOMATIC OPERATION to clear any Special Functions in effect, then connect a dc voltmeter to the AM OUTPUT connector and remove any signal at RF INPUT. Press MHz to fix the tuning, and read the offset voltage on the voltmeter.

FM Calibration (Cont'd)
 (Includes the CALIBRATE, SAVE CAL, and % CAL FACTOR keys,
 and Special Functions 12 and 17)

Procedures (cont'd)

Correcting Measurements with the FM Calibration Factor. Once a calibration factor has been determined, the instrument retains that value in its non-volatile memory. (Refer to Instrument Preset.) This factor can be enabled to automatically correct FM measurements. The calibration factor can also be disabled or displayed.

Enter the appropriate front-panel key or Special Function code for the desired action described in the following table:

Action: FM Calibration Factor	Measurement Mode	Front-Panel Key or Special Function Code	Program Code 
Disable	Any	17.0 SPCL	17.0SP
Enable	FM (From CALIBRATE mode)	(Blue Key) SAVE CAL	SC
	Any	17.1 SPCL	17.1SP
Display	FM	(Blue Key) % CAL FACTOR*	CF
	Any	17.2 SPCL	17.2SP

Calibrating or Cross Checking Another HP 8901 or 8902 RF Signal Analyzer. To compute an FM calibration factor for another RF signal analyzer that has no internal calibrator, or that has an internal calibrator that is to be cross checked, use the Measuring Receiver and its calibrator as follows:

1. Connect the Measuring Receiver's CALIBRATION AM/FM OUTPUT to the input of the RF signal analyzer.
2. Key 12.0 SPCL into the Measuring Receiver. Record the reading that appears on the display. This is the computed, calibrated, peak FM deviation (excluding noise).
3. Key 12.1 SPCL into both instruments. Record the reading that appears on the display of the RF signal analyzer. (If display jitter makes readings difficult, key 5.1 SPCL.) The displayed value is the weighted, peak, residual FM deviation of the calibrator's unmodulated output as demodulated by the RF signal analyzer.

AM Output (Cont'd)



Procedures (cont'd)

Disable the AM ALC loop (6.2 SPCL) and apply the carrier to the RF INPUT. Measure the dc and peak ac signals at AM OUTPUT. Use the first equation in "Description" to compute % AM.

Example

To measure AM depth at AM OUTPUT with the AM ALC turned off, measure V_{off} first:

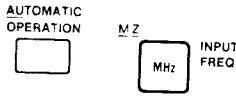
Remove any signal at the RF INPUT and connect a dc voltmeter to AM OUTPUT.

<p>LOCAL (keystrokes)</p>	
<p> (program codes)</p>	<p>AUMZ</p>

For this example, assume the voltmeter reads an offset voltage of -0.36 Vdc. Connect an AM signal to the RF INPUT and tune the Measuring Receiver. Disable the AM ALC by keying 6.2 SPCL.

Measure the dc voltage at AM OUTPUT. (When low AM rates are used, it is easiest to measure the dc voltage at AM OUTPUT before the modulation is applied.) For this example, assume the voltmeter reads -0.46 Vdc (=Vdc). Measure the peak ac voltage at AM OUTPUT. (For low rates an oscilloscope may be necessary.) For this example, assume 0.02 Vpk was measured on an oscilloscope. The % AM is:

$$\% \text{ AM} = \frac{V_{pk} \times 100\%}{|V_{dc} - V_{off}|} = \frac{0.02 \times 100\%}{|(-0.46) - (-0.36)|} = 20\% \text{ AM}$$

FM Calibration
(Includes the CALIBRATE, SAVE CAL, and % CAL FACTOR keys,
and Special Functions 12 and 17)

Description

The accuracy of the Measuring Receiver's FM demodulator can be checked with the internal FM calibrator. The calibration process generates a calibration factor that indicates the FM measurement error (within the accuracy limits of the calibrator). The calibration factor can then be enabled to automatically correct the known FM error in subsequent measurements (Special Function 17 or the Save Calibration function). With the calibration factor enabled, FM measurements can be made with an accuracy typically better than 0.5%. The calibration factor can be enabled, disabled, or displayed at any time.

Other instruments in the family of HP 8901 and 8902 RF signal analyzers can be calibrated or cross checked with the Measuring Receiver's FM calibrator using Special Function 12.

Procedures

Self-Calibration. To determine the measurement error of the Measuring Receiver's FM demodulation circuits, first allow at least a half-hour continuous operation before calibration, then perform the following steps:

1. Connect the CALIBRATION AM/FM OUTPUT to the RF INPUT with a 50 ohm cable (or a sensor module with an internal switch such as the HP 11722A), and select FM.
2. Press the CALIBRATE key. After several seconds, the FM calibration factor will be displayed in % and stored.

The instrument displays 100.00% if no error is measured. A display of 100.17% means the Measuring Receiver is reading 0.17% high. As long as the CALIBRATE key light is on and the cable is connected, calibration continues and the FM calibration factor is updated approximately every 17 seconds. To turn off the calibrator, press the CALIBRATE key or any MEASUREMENT key.

NOTE

For optimum accuracy, the instrument should be continuously operating for at least one half hour before calibration is performed. In addition, the first two FM Calibration Factors received after instrument power-up should not be used even if the instrument is already warm, since the circuits in the audio chain may not be fully settled.

AM Output (Cont'd)

Block Diagram

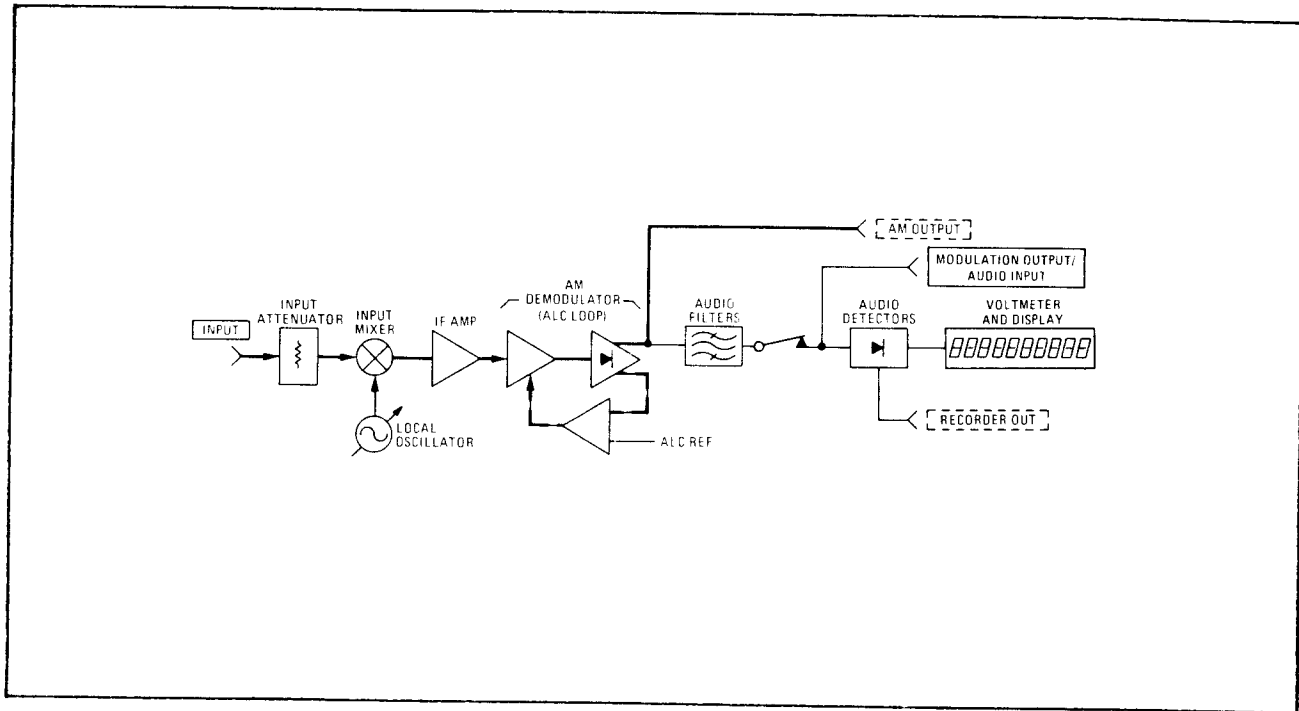

AM Output Block Diagram

Comments

AM OUTPUT contains a significant IF component which is greatest when operating at a carrier of 150 kHz.

The accuracy of measurements made on the AM OUTPUT signal could be degraded during level measurements when the RF peak detector is used (Special Function 35.0).

Related Functions

AM

AM ALC Response Time

FM (Cont'd)
(Includes Special Function 2)

Comments

The PEAK+ detector always detects the upward carrier frequency excursion while the PEAK- detector always detects the downward carrier frequency excursion. The PEAK \pm /2 detector sums the upward and downward frequency excursion and divides the total by two to provide an average peak value. (This value should not to be confused with a detected average value.)

When operating with carrier frequencies below 2.5 MHz, the output signal at MODULATION OUTPUT/AUDIO INPUT is inverted unless using the 455 kHz IF. When operating with carrier frequencies above 2.5 MHz or when using the 455 kHz IF, the signal at FM OUTPUT is inverted.

The routine which automatically selects the modulation range contains regions of overlap between the following displayed peak deviations: 0.35 and 0.4 kHz (750 us de-emphasis, pre-display only), 3.5 and 4 kHz, and 35 and 40 kHz. When using the average detector, ranging occurs with lower modulation levels displayed. If the modulation level is reduced from a higher range into an overlap region, the range may not change. To display the increased resolution, press the FM key a second time. To set the instrument to a selected modulation range, refer to Audio Range.

When the Measuring Receiver is first powered up, demodulated FM, with a sensitivity of 0.01 Vac/MHz (<400 kHz peak deviation range), is available at MODULATION OUTPUT/AUDIO INPUT. The instrument does not autorange to more sensitive ranges because the selection of the FREQ Measurement mode, at power up, automatically disables Error 04 (audio circuits overdriven). When Error 04 is disabled, the instrument only autoranges to less sensitive audio ranges.

AM conditions that cause the carrier signal to disappear either causes inaccuracies in the measurement of FM deviation, or Error 05 (FM squelched).

Related Functions

- Audio Detectors
- Audio Filters
- Audio Frequency
- Audio Range
- FM De-Emphasis
- FM Output
- Ratio
- Residual Noise Effects

Audio Detectors

Description

The Measuring Receiver provides three types of audio detectors; peak, average (rms calibrated), and true rms. These three detectors yield the following six functions:

- Peak +
- Peak -
- Peak +/-2
- Peak Hold
- Avg (RMS Calibrated)
- RMS

The two peak detector keys, when pressed individually, select whether the positive peak (PEAK+) or the negative peak (PEAK-) of the demodulated signal is measured. When the two peak detector keys are pressed simultaneously, the positive and negative peaks are averaged with the following equation:

$$\text{Peak}_{\text{avg}} = \frac{(+\text{Peak}) + (-\text{Peak})}{2}$$

The PEAK HOLD key is used in conjunction with either or both of the two audio peak detectors, PEAK+ or PEAK-. When active, the PEAK HOLD key enables the Measuring Receiver to hold, and display indefinitely, the greatest peak measurement (+ or -).

The AVG (RMS CAL) key uses an average detector that is calibrated to read rms values of sinewaves. Noise and residual measurements can be measured with this detector.

The RMS key uses a true rms detector to measure audio signals.

The selected detector at turn on is PEAK+.

Once selected, the detector remains unchanged and is automatically activated each time modulation measurements are made until another detector is selected.

The signals at MODULATION OUTPUT/AUDIO INPUT, AM OUTPUT, or FM OUTPUT are not affected by the DETECTOR keys.

Procedures

When a modulation measurement is selected, a detector will automatically be activated.

To select a peak detector function, press the PEAK+ or PEAK- keys individually, or press both keys simultaneously.

FM (Cont'd)
(Includes Special Function 2)

HP-IB Program Codes

All HP-IB codes for setting range limits for FM measurements are provided in "Procedures".

FM = M2
SPCL = SP

Indications

Display: When the FM key is pressed, the display shows the measured FM deviation (or the equivalent de-emphasized deviation). The kHz annunciator is displayed.

Front Panel: The LEDs within the selected functions light.

Measurement Technique

The FM on the IF is demodulated by a frequency discriminator. The amplitude of the discriminator's output signal is proportional to the frequency deviation. The demodulated signal is filtered, audio detected, and displayed as kHz deviation.

The FM de-emphasis filter can be inserted ahead of the audio detectors and display circuitry using the PRE DISPLAY key. The demodulated FM signal always passes through the FM de-emphasis filter to be made available at the output of MODULATION OUTPUT/AUDIO INPUT.

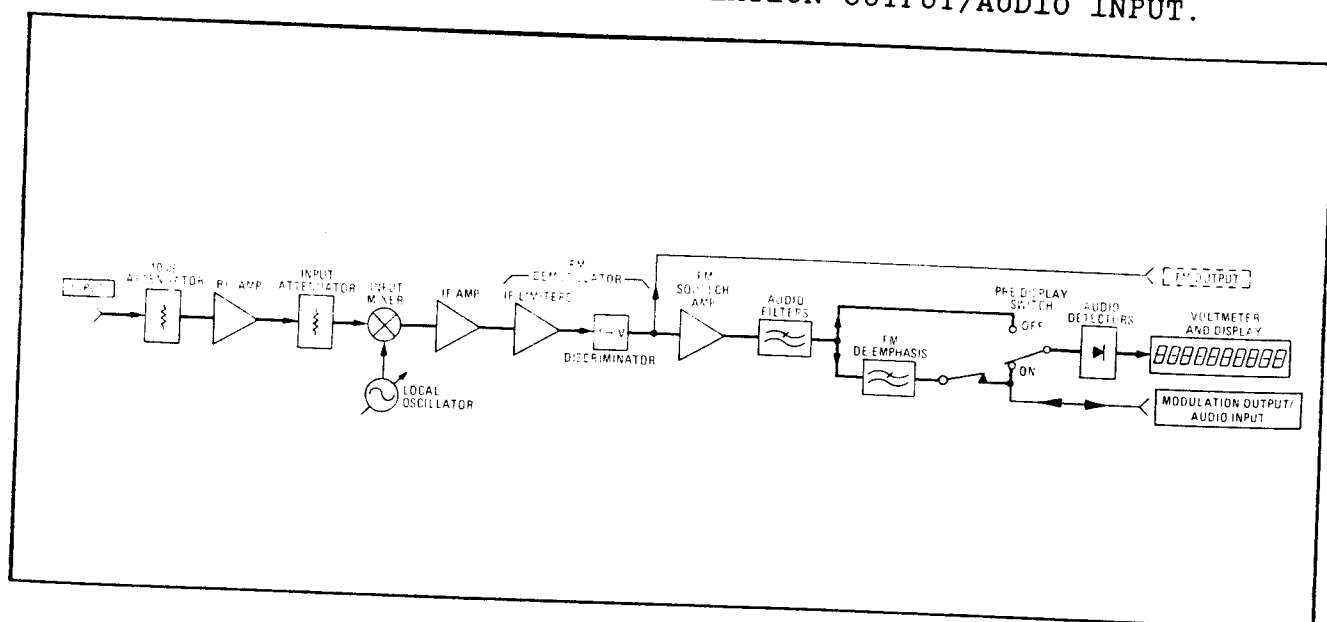

FM Measurement Block Diagram

Audio Detectors (Cont'd)

Procedures (cont'd)

Peak hold must be used with the peak detectors. To initiate peak hold, press the PEAK HOLD key. To re-initiate a new peak hold cycle, press PEAK HOLD again. The display is now updated with the new peak.

To select the average (rms calibrated) detector, press the AVG key.

To select the true rms detector, press the Blue Key and RMS key.

 Program Codes

Function	Program Code 
PEAK+	D1
PEAK-	D2
PEAK HOLD	D3
AVG	D4
RMS	D8
PEAK \pm /2	D9

Indications

Front Panel: A lighted LED indicates the selected detector.

Comments

Only the rms detector can be selected for most audio measurements.

A slower response time for the audio peak detectors can be used. (Refer to Audio Detector Response.)

The PEAK+ detector is selected at power-up.

When the peak hold function is selected, the limited rise time of the peak detector circuitry can cause narrow one-time peaks that could cause slightly low, peak hold measurements. To prevent errors when measuring narrow peaks, repeat the peak-generating process several times while leaving the peak hold function active.

FM (Cont'd)
(Includes Special Function 2)

Procedures (cont'd)

The following table lists the different measurement range limits that can be selected with Special Function 2:

Modulation Range (Peak \pm kHz dev.)	Detector Selected	Special Function Code	Program Code ↔ HP-IB ↔	Display Resolution (Hz)	MODULATION OUTPUT Sensitivity (Vac/% Hz)
Automatic Selection		2.0 SPCL	2.0SP	Automatic Selection	
≤ 0.04	RMS	2.4 SPCL ¹	2.4SP	0.01	100
≤ 0.4	RMS Pk, Avg Pk, Avg, RMS	2.4 SPCL ¹ 2.4 SPCL ¹ 2.1 SPCL ¹	2.4SP 2.4SP 2.1SP	0.1	10
≤ 4	Pk, Avg Pk, Avg, RMS Pk, Avg, RMS	2.4 SPCL 2.1 SPCL 2.2 SPCL ¹	2.4SP 2.1SP 2.2SP	1	1
≤ 40	Pk, Avg, RMS	2.2 SPCL 2.3 SPCL ¹	2.2SP 2.3SP	10	0.1
≤ 400	Pk, Avg, RMS	2.3 SPCL	2.3SP	100	0.01

¹ With 750 μ s de-emphasis, pre-display only.

To filter the demodulated signal, press the appropriate filter keys. (Refer to **Filters, Audio.**) If de-emphasis filtering is desired, select the appropriate time constant and display placement. (Refer to **FM De-emphasis.**)

If FM deviation is to be displayed relative to a reference, enter the value as a ratio reference using the **RATIO** key. (Refer to **Ratio.**)

Example

To measure the positive peak FM deviation of a signal in a 50 Hz to 15 kHz demodulated signal bandwidth, and place a 750 μ s time constant de-emphasis before the display:

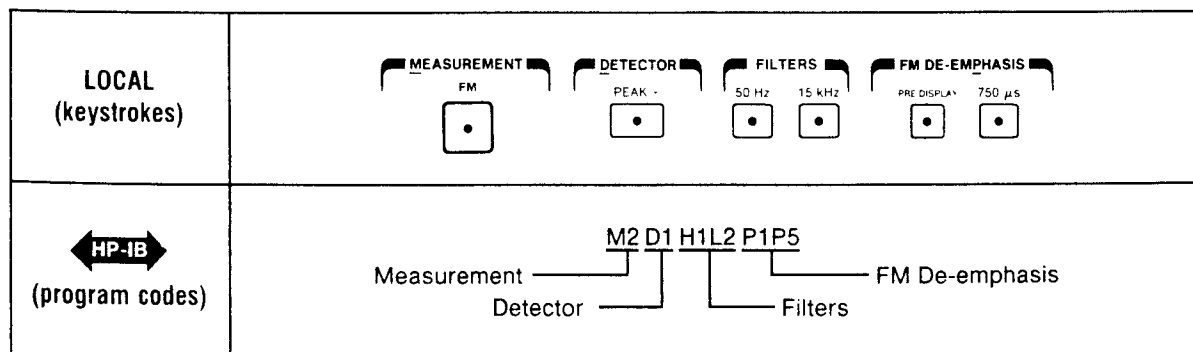

Audio Detectors (Cont'd)

Comments (cont'd)

If the PEAK HOLD key is pressed while the average or true rms detector is active, the detector will switch to the last peak detector previously selected. If the PEAK HOLD key is pressed when the Peak $\pm/2$ function is selected, the key will not light.

HP-IB

In remote operation, new peak hold cycles may only be initiated by code D3. Thus, if the instrument is in HP-IB Hold mode (code T1), issue code D3 to initiate a peak hold cycle. Although the display cannot be updated when in HP-IB Hold, the peak is captured, stored and updated. Upon leaving HP-IB hold via the triggering codes (T2 or T3), the data output will represent the greatest peak captured since the peak hold cycle was initiated.

Related Functions

AM

Audio Detector Response

FM

QM

Recorder Output

FM

(Includes Special Function 2)

Description

The FM key enables the Measuring Receiver to measure the FM deviation of the tuned input signal. Special Function 2 enables the instrument to set limits on the range of FM deviation that can be measured.

The demodulated FM is present at MODULATION OUTPUT/AUDIO INPUT (unless AUDIO INPUT has been selected). The demodulated FM is usually present at the rear-panel FM OUTPUT connector. (Refer to FM OUTPUT.)

FM Measurements are specified for rates from 20 Hz to 10 kHz for carriers 10 MHz and below (or whenever the 455 kHz IF is used) and from 20 Hz to 200 kHz for carriers from 10 to 1300 MHz (1.5 MHz IF only). The corresponding 3 dB audio bandwidths are 0.5 Hz to 15 kHz for carriers 10 MHz and below (or with the 455 kHz IF) and 0.2 Hz to 260 kHz for carriers from 10 to 1300 MHz (1.5 MHz IF only). Peak deviations up to 40 kHz maximum can be measured on carriers below 10 MHz and peak deviations up to 400 kHz maximum can be measured on carriers above 10 MHz.

The demodulated signal's frequency and distortion can also be characterized. (Refer to Audio Distortion and Level and to Audio Frequency.)

Procedures

To make an FM measurement, first tune the instrument to the input signal. (Refer to RF Frequency Tuning or press AUTOMATIC OPERATION.) Press the FM key.

Select an audio detector: PEAK+, PEAK-, or AVG. The RMS detector, selected by pressing the Blue Key and the RMS key, is not quite as accurate in measuring FM and is usually only used for audio distortion measurements. (Refer to Audio Distortion and Level and to Audio Detectors.)

Audio Detector Response (Special Function 5)

Description

When making modulation measurements, the audio peak detector response (for peak measurements), and the digital averaging response (for rms measurements) is usually fast. A slower response time (narrower bandwidth setting) can be initiated using Special Function 5.

The slow response time (narrower bandwidth setting) helps stabilize measurements on unstable or noisy signals, or whenever measurement display jitter is considered excessive.

Procedure

The Measuring Receiver normally is set for a fast response. To change from fast to slow or vice versa, enter the corresponding Special Function code, then press the SPCL key:

Audio Detector Response	Special Function Code	Program Code ◀HP-IB▶
Fast	5.0 SPCL	5.0S'
Slow	5.1 SPCL	5.1SP

◀HP-IB▶ Program Codes

For HP-IB codes, refer to "Procedure".

Indications

Display: As the numeric code is entered, it appears on the display. When the SPCL key is pressed, the display returns to the measurement previously selected.

Front Panel: The LED within the SPCL key lights (unless 5.0 SPCL is entered).

Comments

When the instrument is first turned on or when the AUTOMATIC OPERATION or INSTR PRESET key is selected, the audio detector time constant returns to the fast-response mode.

Related Functions

Audio Detectors
Recorder Output

Filters, RF and IF (Cont'd) (Special Function 3)

HP-IB Program Codes

The HP-IB codes for selecting various combinations of RF and IF filters are provided in "Procedure".

Indications

Display: As the numeric code is entered, it appears on the front-panel display. When the SPCL key is pressed, the display returns to the measurement previously selected.

Front Panel: Unless Special Function 3.0 is entered, the light within the SPCL key lights.

Block Diagram

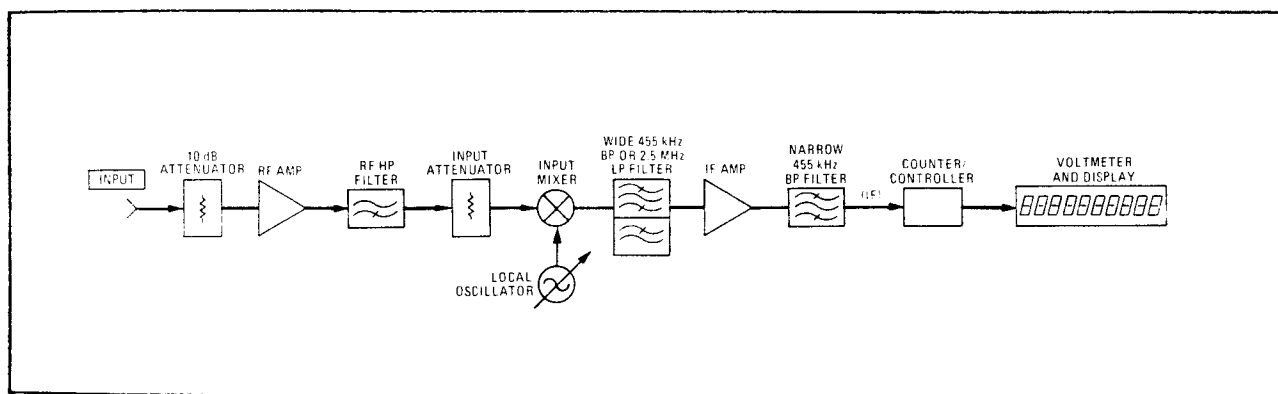

Block Diagram of RF and IF Filters

Comments

When the instrument is first powered up or when AUTOMATIC OPERATION or INSTR PRESET is selected, RF and IF Filters are placed in the automatic selection mode.

When a new IF frequency is selected, the instrument immediately retunes.

Many measurements can typically be made on very low-level signals. Using the narrow bandwidth of the 455 kHz IF for signal frequencies less than 2.5 MHz or greater than 10 MHz increases the sensitivity and selectivity of the Measuring Receiver. Manual insertion of RF input attenuation and gain also increases sensitivity. (Refer to RF Input Attenuation and Gain.)

Related Functions

IF Frequency
IF Level
Range Hold

RF Frequency Tuning
Special Functions

Audio Distortion and Level
(Includes Special Function 30, the
1 kHz DISTN, 400 Hz DISTN, and RMS Keys, and the
AUDIO INPUT Key)

Description

The AUDIO DISTN key enables the Measuring Receiver to make audio distortion measurements. To measure the distortion, the instrument compares the input signal level measured by the true rms detector to the same measurement with the fundamental frequency removed. Distortion can be measured at frequencies of either 1 kHz or 400 Hz using the 1 kHz DISTN or 400 Hz DISTN keys (respectively). Once selected, the 1 kHz or 400 Hz Distortion Measurement mode remains unchanged and is automatically activated each time audio measurements are made until another Distortion Measurement mode is selected.

Special Function 30.0 enables the Measuring Receiver to measure the true rms level input available at MODULATION OUTPUT/AUDIO INPUT.

The distortion and level of external audio signals can be characterized using the AUDIO INPUT key when the input signal is applied to MODULATION OUTPUT/AUDIO INPUT. When the AUDIO INPUT key is not selected, the Measuring Receiver can measure the distortion (but not the level) of the audio signal that is demodulated from the signal at the RF INPUT connector.

Procedures

To measure the audio distortion of the audio signal that is demodulated from the signal at the RF INPUT connector, press the S (shift) key and the AUDIO DISTN key. For measurements on signals at the MODULATION OUTPUT/AUDIO INPUT, also press the AUDIO INPUT key. Only the true rms detector can be used; no other detector can be selected.

To change the bandwidth of the internally demodulated audio signal, press the desired filter keys. (Refer to Audio Filters.)

If measurements are to be made on a 1 kHz audio signal, press the Blue Key and 1 kHz DISTN (PEAK+) key. If measurements are to be made on a 400 Hz audio signal, press the Blue Key and 400 Hz DISTN (PEAK+) key.

To measure the true rms level of the input signal at MODULATION OUTPUT/AUDIO INPUT, key in 30.0 and press the SPCL key.

If audio distortion or level are to be displayed relative to a reference, enter the value as a ratio reference using the RATIO key. (Refer to Ratio.)

Filters, RF and IF (Special Function 3)

Description

To eliminate unwanted low-frequency signals in the RF signal path, an RF filter can be inserted. The 5.25 MHz High-Pass Filter is manually selectable with Special Function 3. Since the IF generally responds to signals less than 2.5 MHz, the filter eliminates any low frequencies that might be present on the input. (For input signals of 150 kHz to 10 MHz, the filter should be switched out.)

The Input Mixer down-converts the RF input to the IF. The IF is usually centered at 1.5 MHz for input signals 10 to 1300 MHz. (An IF of 455 kHz can be manually selected.) For signals between 2.5 MHz and 10 MHz, the IF is 455 kHz. Below 2.5 MHz, the signal is passed directly into the IF without down-conversion (unless the 455 kHz IF has been manually selected). IF filters determine the frequency response of each IF.

When the 1.5 MHz IF is selected, the IF frequency response is determined by the 2.5 MHz Low-Pass (LP) Filter.

When the 455 kHz IF is selected, the Wide 455 kHz Bandpass (BP) Filter determines the IF frequency response, unless a tuned RF level measurement is made which inserts the Narrow 455 kHz BP Filter. Various combinations of these filters can be manually inserted using Special Function 3.

Procedure

To select a desired combination of RF and IF filters, or to re-enter the automatic selection mode, key in the corresponding Special Function code, then press the SPCL key:

Special Function Code	Program Code ↔ HP-IB ↔	IF Frequency	Wide IF Filter	Narrow IF Filter (30 kHz BW)	RF High-Pass Filter (5.25 MHz)
3.0 SPCL	3.0SP	Automatic Selection			OUT
3.1 SPCL	3.1SP	455 kHz	200 kHz BW	OUT	OUT
3.2 SPCL	3.2SP	1.5 MHz	2.5 MHz Low-Pass	OUT	OUT
3.3 SPCL	3.3SP	455 kHz	200 kHz BW	OUT	IN
3.4 SPCL	3.4SP	1.5 MHz	2.5 MHz Low-Pass	OUT	IN
3.5 SPCL	3.5SP	455 kHz	200 kHz BW	IN	OUT
3.6 SPCL	3.6SP	455 kHz	2.5 MHz Low-Pass	IN	OUT
3.7 SPCL	3.7SP	455 kHz	200 kHz BW	IN	IN
3.8 SPCL	3.8SP	455 kHz	2.5 MHz Low-Pass	IN	IN

Audio Distortion and Level (Cont'd)
 (Includes Special Function 30,
 the 1 kHz DISTN, 400 Hz DISTN, and RMS Keys, and the
 AUDIO INPUT Key)

HP-IB Program Codes

AUDIO DISTN = S2
 AUDIO INPUT = A1
 MODULATION OUTPUT = A0
 1 kHz DISTN = D5
 400 Hz DISTN = D6
 LIN results = LN
 LOG results = LG
 mV units = MV
 uV units = UV
 VOLTS units = VL
 SPCL = SP

Indications

Display: When AUDIO DISTN is selected, the value of audio distortion is displayed in % or dB. The 1 kHz or 400 Hz annunciator is also displayed.

When Special Function 30.0 is selected, the numeric code appears on the display. When the SPCL key is pressed, the measured rms value is displayed, and the selected units annunciator lights. If uV units are selected, the display indicates the measured value in scientific notation; that is, the measured value is followed by a signed, power-of-ten multiplier. The following table shows the annunciator units for linear and logarithmic formats.

Linear Unit	Logarithmic Unit
W	dBm
V	dBV
mV	dB mV
μ V	dB μ V

Front Panel: When AUDIO DISTN is selected, the LEDs within the S (shift) key and the AUDIO DISTN keys light. The LED next to RMS lights.

When AUDIO INPUT is selected, the LED within the key lights and the LEDs under MODULATION OUTPUT are turned off. If AUDIO INPUT is not selected or is turned off, the appropriate LED lights.

Filters, Audio (Cont'd)

Comments (cont'd)

The individual filter characteristics are given below. The 3 dB points are typically accurate to $\pm 3\%$.

High-Pass Filters:

50 Hz High Pass: Two pole Butterworth 1% flat ≥ 200 Hz
300 Hz High Pass: Two pole Butterworth 1% flat ≥ 1 kHz

Low-Pass Filters:

3 kHz Low Pass: Five pole Butterworth 1% flat ≤ 1 kHz
15 kHz Low Pass: Five pole Chebyshev 1% flat ≤ 10 kHz
>20 kHz Low Pass: Nine pole Bessel 1% flat ≤ 10 kHz. (When used with squarewave modulation, this filter typically overshoots $< 1\%$. This filter's 3 dB point is typically 110 kHz.)

Related Functions

AM
Filters, RF
FM
FM De-emphasis
IF Frequency

Audio Distortion and Level (Cont'd)
 (Includes Special Function 30, the
 1 kHz DISTN, 400 Hz DISTN, and RMS Keys, and the
 AUDIO INPUT Key)

Indications (cont'd)

Front Panel: When Special Function 30.0 is selected, the LEDs (cont'd) within the SPCL and AUDIO INPUT keys light. The LED next to RMS lights.

If filters or FM de-emphasis has been selected, these LEDs are turned off.

Measurement Technique

To measure distortion, the broadband audio signal is first measured with the true rms detector; then the audio signal path is switched to go through a notch filter at the distortion frequency (1 kHz or 400 Hz). The notch filter has an approximate 55 dB attenuation at the distortion frequency with a 10% total bandwidth. The two voltages out of the rms detector are measured by the internal voltmeter and the ratio is taken. This ratio is then the distortion of the audio signal.

The direction of the signal at MODULATION OUTPUT/AUDIO INPUT is controlled by the AUDIO INPUT key. The connector has an input impedance of approximately 100 kohms and an output impedance of 600 ohms.

The true rms level (from 0V to 4V) of any audio signal (from 20 Hz to 40 kHz) can be measured using the same rms detector.

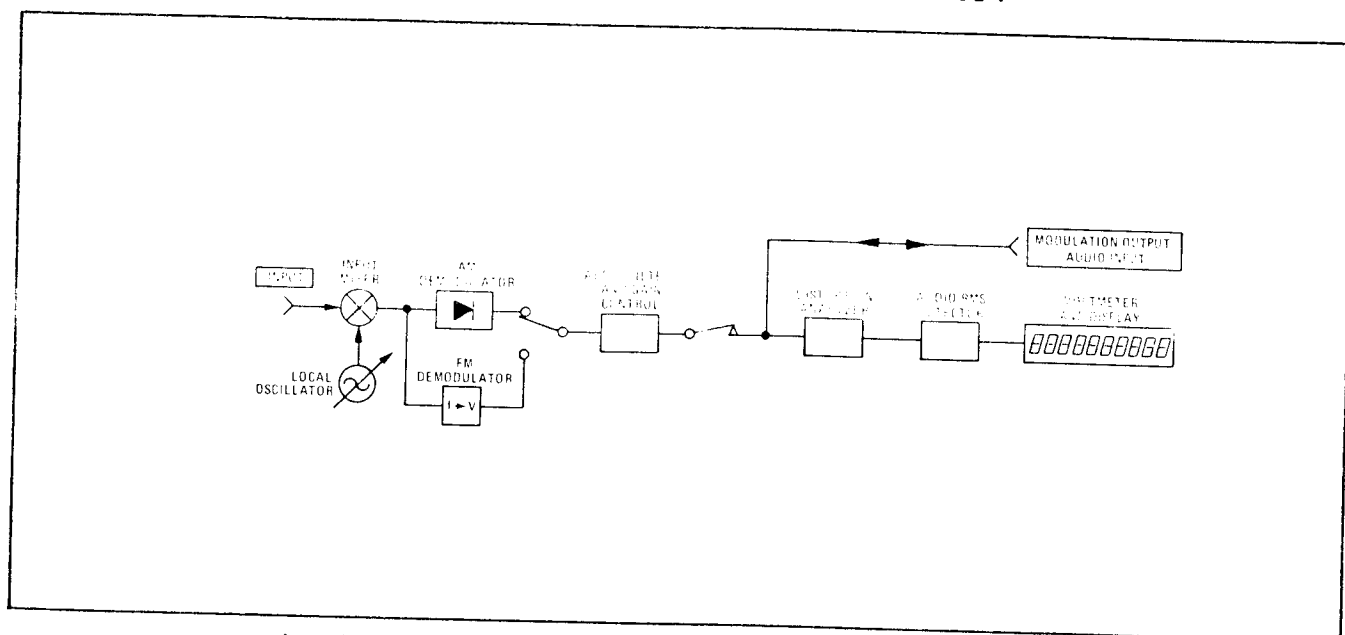

Audio Distortion and Level Block Diagram

Filters, Audio (Cont'd)

Block Diagram

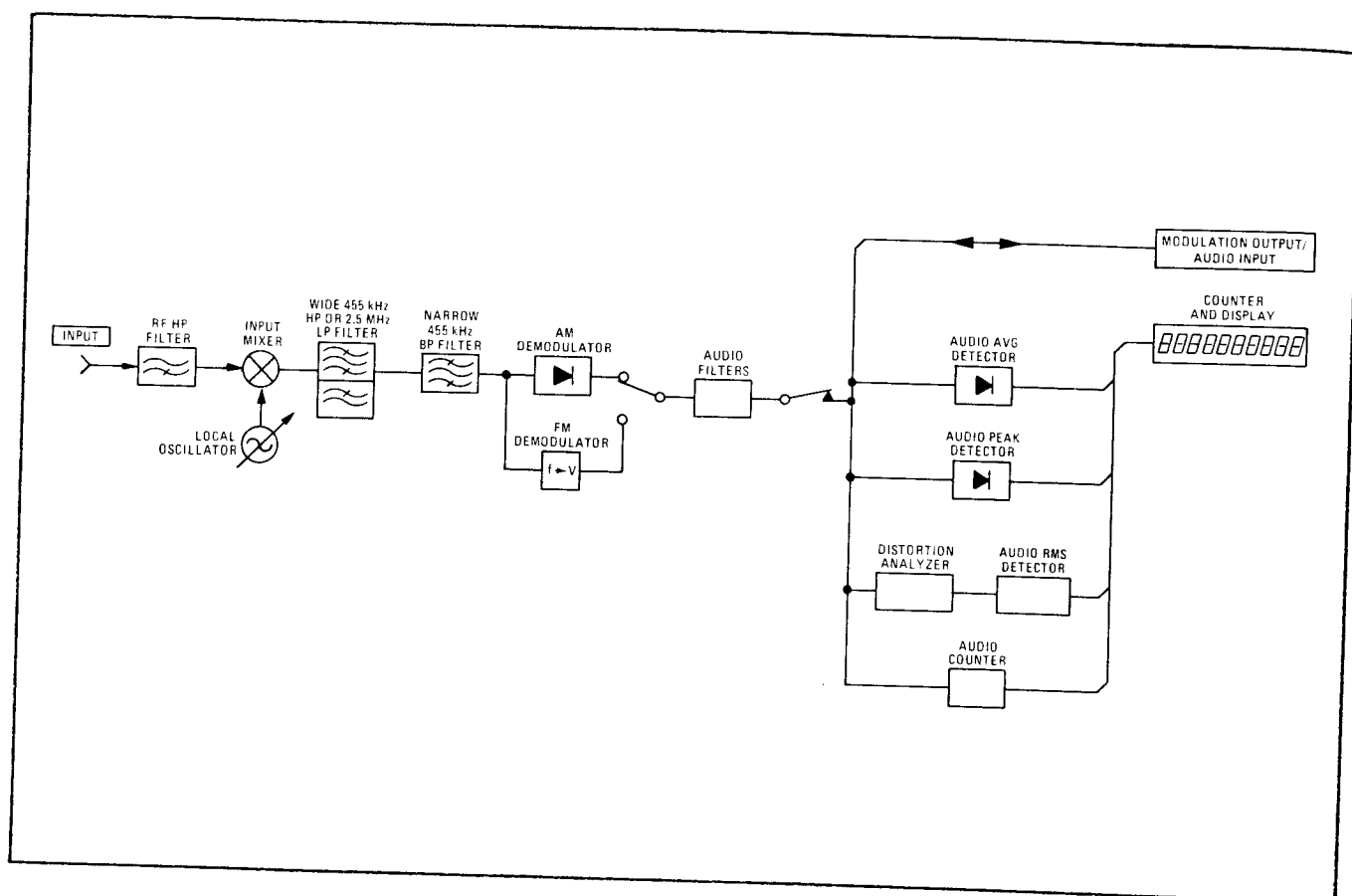

Audio Filters Block Diagram

Comments

The selected filters are always in the path of the demodulated signal independent of the selection of a modulation measurement. Thus, unless turned off, the output of MODULATION OUTPUT/AUDIO INPUT is filtered. In addition, the selected filters remain in effect when switching between modulation measurements.

Under certain conditions, filters are inserted automatically. When the 455 kHz IF is used, or when the RF input is less than 2.5 MHz, the 15 kHz low-pass filter is inserted (unless another low-pass filter has been selected). The 15 kHz low-pass filter is selected when operating with the 455 kHz IF is automatically turned off when the 1.5 MHz IF is selected.

With no filters selected, the post-demodulation bandwidth is from 20 Hz to greater than 200 kHz, however, the IF circuits and demodulators impose more severe bandwidth limits. Refer to each specific measurement in these Detailed Operating Instructions for bandwidth limitations.

Audio Distortion and Level (Cont'd)
(Includes Special Function 30, the
1 kHz DISTN, 400 Hz DISTN, and RMS Keys, and the
AUDIO INPUT Key)

Comments

At power-up, the instrument defaults to making 1 kHz distortion measurements.

To convert the measured audio level into watts, use the following equation:

$$20 \text{ Log voltage (in volts)}$$

Related Functions

Audio Detectors
Audio Detector Response
Audio Filters
Audio Frequency
SINAD

Filters, Audio

Description

High-pass and low-pass filters can be inserted into the path of the demodulated signal through the use of the HP and LP FILTER keys.

Procedures

Insert the desired demodulated signal filter by pressing the appropriate keys.

- o Only one high-pass and one low-pass filter can be inserted at once.
- o To remove a filter, press the key again.
- o To select a different filter, press the key corresponding to the desired filter.
- o HP-IB codes for the various filter keys (listed in the following table) only insert the filters. To remove a high-pass or low-pass filter via HP-IB, use code H0 or L0 (respectively), or select another filter.

HP-IB Program Codes

HP FILTER	Program Code ↔ HP-IB ↔	LP FILTER	Program Code ↔ HP-IB ↔
ALL OFF 50 Hz 300 Hz	H0 H1 H2	ALL OFF 3 kHz 15 kHz >20 kHz	L0 L1 L2 L3

Indications

When a filter is inserted (by either automatic or manual selection), the LED within that filter's key lights.

Audio Frequency (Includes the AUDIO INPUT key)

Description

The AUDIO FREQ key enables the Measuring Receiver to count the frequency of either demodulated internal signals or external audio signals.

The AUDIO INPUT key selects measurement of either internal or external signals.

Procedures

To count the frequency of the audio signal that is demodulated from the signal at the RF INPUT connector, press the S (shift) key and the AUDIO FREQ key.

To count the frequency of the signal at the RF INPUT connector, follow the above procedure, and then press the AUDIO INPUT key.

If audio frequency is to be displayed relative to a reference, enter the value as a ratio reference using the Ratio function. (Refer to Ratio.)

HP-IB Program Code

AUDIO FREQ = S1

Indications

Display: When AUDIO FREQ is selected, the frequency is displayed in kHz with a resolution of 0.001 Hz.

Front Panel: When AUDIO FREQ is selected, the LEDs within the S (shift) key and the AUDIO FREQ keys light.

When AUDIO INPUT is selected, the LED within the key lights and the LEDs under MODULATION OUTPUT are turned off.

Measurement Technique

The audio frequency measurement uses a reciprocal counter to count either demodulated internal signals or external audio signals. The Measuring Receiver gates the 10 MHz time base with the audio signal so the period of the audio signal is equal to the number of time base pulses divided by 10 MHz. The frequency is 1/period. The time base is counted for 100 ms to achieve the resolution of 0.001 Hz.

External Attenuation (Cont'd)
(Includes the dB EXT ATTEN key and Special Function 25)

HP-IB Program Codes

dB EXT ATTEN off = N0
dB EXT ATTEN on = N1
SPCL = SP

Indications

Display: When the dB EXT ATTEN key is pressed, the Measuring Receiver displays subsequent level measurements using the entered offset.

When Special Function 25.2 is entered, the current value of entered external attenuation is displayed with the dB annunciator. The display is timed out.

Front Panel: The dB EXT ATTEN annunciator lights when pressed. Special Function 25.2 causes the LED within the SPCL key to light and then time out.

Comments

If another Measurement mode is selected, and then a level Measurement mode is re-entered, the instrument automatically re-enters the external attenuation mode with the previous offset value to offset subsequent measurements.

Related Functions

Peak Tuned RF Level
Ratio
RF Level
RF Power
Tuned RF Level

Audio Frequency (Cont'd)
(Includes the AUDIO INPUT key)

Measurement Technique (cont'd)

The direction of the signal at MODULATION OUTPUT/AUDIO INPUT is controlled by the AUDIO INPUT key. The connector has an input impedance of approximately 100 kohms and an output impedance of 600 ohms.

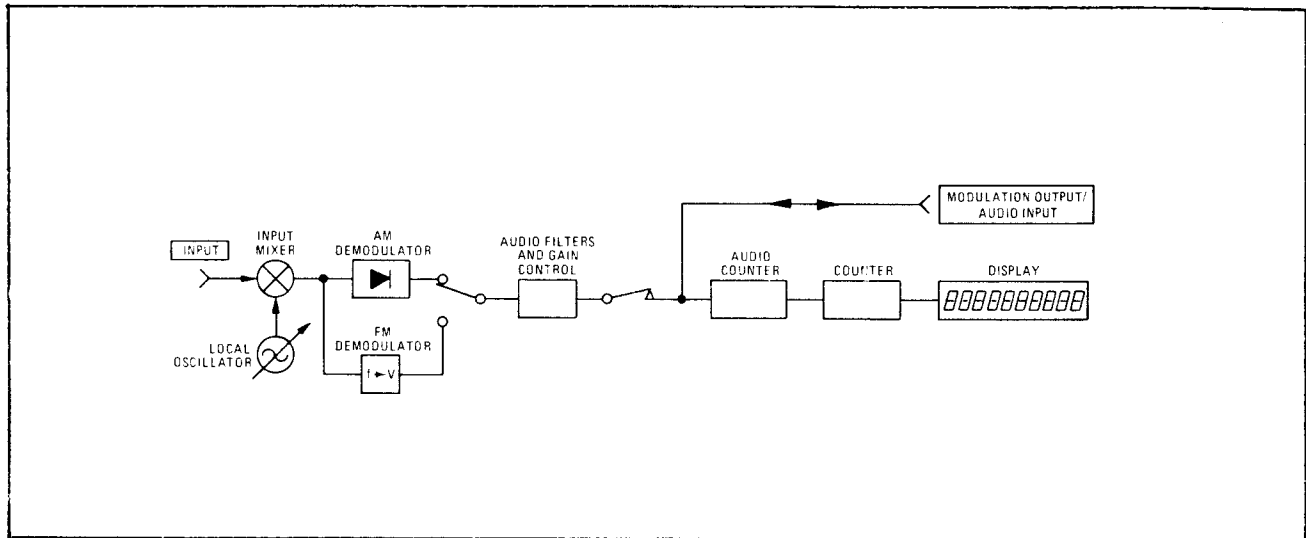

Audio Frequency Block Diagram

Related Functions

Audio Distortion and Level
 SINAD

External Attenuation
 (Includes the dB EXT ATTEN key and Special Function 25)

Description

Level measurements can be offset with external attenuation or gain using the dB EXT ATTEN key.

Special Function 25.2 enables the Measuring Receiver to display the value of the selected external attenuation/gain.

MODULATION OUTPUT/AUDIO INPUT is blanked during most level measurements.

Procedures

To enter external attenuation:

1. Press the keys corresponding to the value of external attenuation or gain.
2. Use a negative sign to enter a gain value by pressing the Blue Key and the (-) key (. key). No sign indication is necessary for entering attenuation.
3. Press the Blue Key and dB EXT ATTEN (LOG/LIN) key.

To display the current offset in dB, key in 25.2 SPCL.

To exit external attenuation, press the Blue Key and dB EXT ATTEN key again. To re-enter external attenuation, press the Blue Key and dB EXT ATTEN key again.

Example

To enter external gain of 10 dB as an offset to subsequent power measurements:

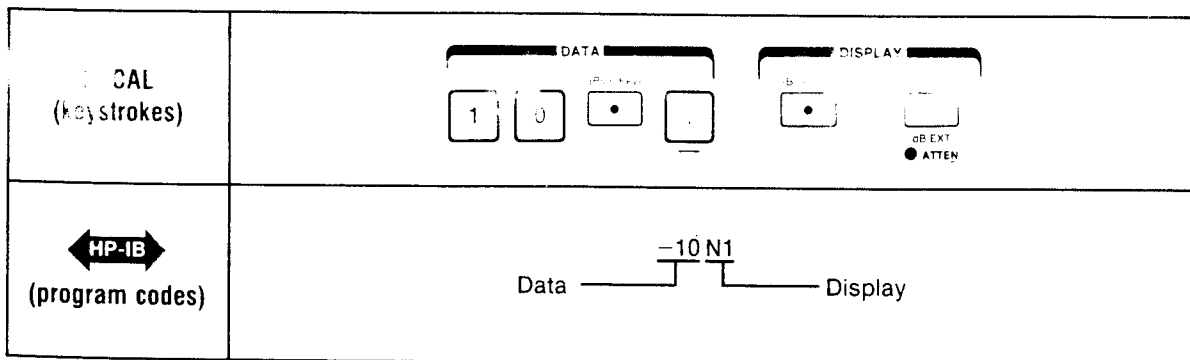

Audio Range (Special Function 2)

Description

The Measuring Receiver is usually set to automatically select the audio range appropriate for the desired measurement. To limit the range of possible measurement, the audio range can be manually set using Special Function 2.

Procedure

To set the modulation range to a selected range, or to re-enter the automatic selection mode, key in the corresponding Special Function code, then press the SPCL key:

Modulation Range Peak \pm (%)	Detector Selected	Special Function Code	Program Code ↔ HP-IB ↔	Display Resolution (%)	MODULATION OUTPUT Sensitivity (Vac/% AM)
Automatic Selection		2.0 SPCL	2.0SP	Automatic Selection	
≤ 4	RMS	2.4 SPCL	2.4SP	0.001	1
≤ 40	Pk, Avg	2.4 SPCL	2.4SP	0.01	0.1
≤ 40	Pk, Avg, RMS	2.1 SPCL	2.1SP	0.01	0.1
≤ 100	Pk, Avg, RMS	2.2 SPCL or 2.3 SPCL	2.2SP or 2.3SP	0.1	0.01

Error Message Summary (Cont'd)

Service Errors		
Error Code	Message	Corrective Action
40-89	Service-related errors.	Refer to service section of HP 8902A instrument manual.

Comments:

Errors 40 through 89 Service errors are normally disabled.

Audio Range (Cont'd)
(Special Function 2)

Procedure (cont'd)

FM

Modulation Range (Peak \pm kHz dev.)	Detector Selected	Special Function Code	Program Code ↔ HP-IB ↔	Display Resolution (Hz)	MODULATION OUTPUT Sensitivity (Vac/% Hz)
Automatic Selection		2.0 SPCL	2.0SP	Automatic Selection	
≤ 0.04	RMS	2.4 SPCL ¹	2.4SP	0.01	100
≤ 0.4	RMS Pk, Avg Pk, Avg, RMS	2.4 SPCL 2.4 SPCL ¹ 2.1 SPCL ¹	2.4SP 2.4SP 2.1SP	0.1	10
≤ 4	Pk, Avg Pk, Avg, RMS Pk, Avg, RMS	2.4 SPCL 2.1 SPCL 2.2 SPCL ¹	2.4SP 2.1SP 2.2SP	1	1
≤ 40	Pk, Avg, RMS	2.2 SPCL 2.3 SPCL ¹	2.2SP 2.3SP	10	0.1
≤ 400	Pk, Avg, RMS	2.3 SPCL	2.3SP	100	0.01

¹ With 750 μ s de-emphasis, pre-display only.

 ϕ M

Modulation Range (Peak \pm rad. dev.)	Detector Selected	Special Function Code	Program Code ↔ HP-IB ↔	Display Resolution (radians)	MODULATION OUTPUT Sensitivity (mVac/radian)
Automatic Selection		2.0 SPCL	2.0SP	Automatic Selection	
≤ 0.4	RMS	2.4 SPCL	2.4SP	0.0001	10
≤ 4	Pk, Avg	2.4 SPCL	2.4SP	0.001	1
≤ 4	Pk, Avg, RMS	2.1 SPCL	2.1SP	0.001	1
≤ 40	Pk, Avg, RMS	2.2 SPCL	2.2SP	0.01	0.1
≤ 400	Pk, Avg, RMS	2.3 SPCL	2.3SP	0.1	0.01

Error Message Summary (Cont'd)

Entry Errors		
Error Code	Message	Corrective Action
20	Entered value out of range.	Re-enter new value.
21	Invalid key sequence.	Check for compatibility of functions selected.
22	Invalid Special Function prefix.	Re-enter correct Special Function Code.
23	Invalid Special Function suffix.	Re-enter correct Special Function Code.
24	Invalid HP-IB code.	Re-enter correct HP-IB code.
25	Special Functions selected not compatible with selected measurement.	Press AUTOMATIC OPERATION
26	End of RF Power calibration factor table reached.	Check number of entries.

Comments:

Error 21 Error 21 times out.

Error 22 Error 22 times out. (Refer to Special Functions.)

Error 23 Error 23 times out. (Refer to Special Functions.)

Error 24 Error 24 always causes the issuance of a Require Service message on the HP-IB.

Tuned RF Level Calibration Errors		
Error Code	Message	Corrective Action
30	Manual input attenuation or gain selection.	Change RF input attenuation and gain.
31	Requires new power reference.	Calibrate RF Power before attempting calibration of Tuned RF Level.
32	Manual IF gain selection.	Change IF gain.
33	Power sensor reference error.	Maintain consistency in frequency and level at SENSOR during calibration.
34	Signal lost during calibration.	Maintain frequency stability at RF INPUT during calibration.
35	Level error during calibration.	Maintain signal stability at RF INPUT during calibration.

Audio Range (Cont'd)
(Special Function 2)

HP-IB Program Codes

For HP-IB codes, refer to "Procedure".

Indications

Display: As the numeric code is entered, it appears on the display. When the SPCL key is pressed, the display returns to the measurement previously selected.

Front Panel: The LED within the SPCL key lights (unless 2.0 SPCL is entered).

Comments

When the instrument is first powered up or when AUTOMATIC OPERATION or INSTR PRESET is selected, the audio range is placed in the automatic selection mode.

Special Function 2.4 is usually only used in audio distortion measurements. If the true RMS detector is not selected, Special Function 2.4 selects the identical range as that selected with Special Function 2.1.

When the audio range selected is too high (that is, the audio signal level is too low), no error is generated, and the output of MODULATION OUTPUT/AUDIO INPUT tracks the displayed values. When the audio range is too low (that is, the audio signal level is too high), Error 04 is generated. Error 04 might not be generated exactly at the nominal level at which ranges are switched.

When Error 04 is disabled (refer to Disable Error Message Control), the Measuring Receiver automatically ranges to the higher audio ranges. This feature is used most often when modulation varies widely with time (such as off-the-air demodulation of a broadcast signal).

Related Functions

AM
Disable Error Message Control
FM
 ϕ M
Range Hold
Special Functions

Error Message Summary (Cont'd)

Comments (cont'd):

- Error 04 Error 04 designates either an improperly set audio range, or an attempt to measure modulation levels greater than those specified. Refer to Audio Range.
- Error 05 Error 05 often occurs when FM or ϕ M measurements are attempted on low-level signals with high AM depth (greater than 90%). Error 05 disables MODULATION OUTPUT/AUDIO INPUT.
- Error 06 Maximum allowable input level is 7 Vrms (1W peak).
- Error 07 If displayed during modulation measurements, increase audio range. If displayed during level measurements, increase RF input attenuation.
- Error 08 If the connection from CALIBRATION AM/FM OUTPUT to RF INPUT is intact, this error may indicate calibrator malfunction.
- Error 09 Error 09 display times out. If the option is installed, Error 09 displayed can reflect an option malfunction.
- Error 10 Error 10 turns off MODULATION OUTPUT/AUDIO INPUT.
- Error 11 In dB RATIO, Error 11 is displayed when measurement results equal 0. (Log of 0 not allowed.)
- Error 12 Error 12 must be requested by Special Function 15. (Refer to Special Functions.)
- Error 13 Error 13 usually only occurs when the power sensor is disconnected during an RF power measurement.
- Error 14 Error 14 will not occur when using a sensor module (such as the HP 11722A) or a power sensor with an RF switch controlled by voltages accessed from the rear panel. (Refer to Remote Control RF Switch.)
- Error 15 Refer to RF Power Calibration Factors for entry and edit information concerning calibration factors.
- Error 96 Error 96 corresponds to a display of two dashes (--). Error 96 can occur when no signal is applied or when Error 03 is disabled and the instrument is manually tuned where no signal is found. Error 96 (--) turns off MODULATION OUTPUT/AUDIO INPUT.

Attenuator Measurements (Includes the SET REF key and Special Function 26)

Description

The Measuring Receiver uses the SET REF function to accurately measure relative devices such as attenuators or amplifiers. Pressing the SET REF key, while in the Tuned RF Level Measurement mode, establishes the current RF input signal as the reference signal for all other power measurements made at that frequency.

Special Function 26 enables the Measuring Receiver to enter and exit relative power measurements.

MODULATION OUTPUT/AUDIO INPUT is blanked during tuned RF level measurements.

The SET REF key should be used instead of the RATIO key for relative power measurements, but the Ratio function is also available.

Procedures

To make a relative power measurement, connect an RF cable (or sensor module) to the RF INPUT connector of the Measuring Receiver. Tune the instrument to the frequency of interest. (Refer to RF Frequency Tuning.)

Press the S (shift) and TUNED RF LEVEL keys and wait for the measurement value to be displayed. (The instrument defaults to making Synchronous Tuned RF Level measurements but Average Tuned RF Level measurements can be used with signals that have significant residual FM. Refer to Tuned RF Level for an explanation of these two modes and their application.)

Press the Blue Key and the SET REF key to set the initial reference for subsequent relative measurements. Press the RATIO key to display the level in % or dB. As the input level changes, the level relative to the initial reference is displayed.

If RECAL is displayed, calibrate the subsequent ranges by pressing the CALIBRATE key. (Refer to Tuned RF Level Calibration and Calibration Factors for a description of calibration factors and their derivation.)

Press 26.0 SPCL to enter the absolute Tuned RF Level mode.

Press 26.1 SPCL to enter the relative Tuned RF Level mode. (Pressing the SET REF key also puts the instrument in the relative Tuned RF Level measurement mode.)

Error Message Summary (Cont'd)

Error Messages

The following table describes all Operating Errors and includes the error code, message, and the action typically required to remove the error-causing condition. The Comments column that follows provides additional information and references pertaining to particular errors.

Operating Errors		
Error Code	Message	Corrective Action
01	IF frequency error.	Retune to signal at input.
02	Input level too high.	Increase RF input attenuation and gain.
03	Input Level too low.	Decrease RF input attenuation and gain.
04	Audio circuits overdriven.	Increase audio range.
05	FM squelched.	Reduce signal level variations (AM) at RF INPUT.
06	RF input overload.	Reduce RF signal level at RF INPUT, then press any key.
07	Voltmeter and display overload.	Increase audio range.
08	Calibrator error.	Connect CALIBRATION AM/FM OUTPUT to RF INPUT or turn off calibrator.
09	Option not installed.	Select another instrument function.
10	Input frequency out of range.	Adjust input frequency to within specified limits.
11	Calculated value out of range.	Conversion from % to dB is not possible. Press LOG/LIN for linear display.
12	Time Base oven cold (Option 002).	For highest accuracy, wait until oven is warm. (Refer to Special Function 15.)
13	Power sensor not connected.	Press RF POWER. RF level measurement is initiated if the power sensor is not connected.
14	Power sensor cannot zero.	Assure zero power at SENSOR input.
15	Calibration factor error.	Input calibration factors.
16	Audio circuits underdriven.	Increase external audio input level.
18	RF Power will not calibrate.	Assure 0 dBm at SENSOR input.
19	Tuned RF Level circuits underdriven.	Press Automatic Operation.
96	(HP-IB only) No input signal sensed by instrument.	Increase signal level at RF INPUT or retune

Comments:

Error 01 With the 1.5 MHz IF, the IF frequency must be $1.5 \text{ MHz} \pm 50 \text{ kHz}$.

With the 455 kHz IF, the IF frequency must be $455 \text{ kHz} \pm 2.5 \text{ kHz}$.

Refer to RF Frequency Tuning. Error 01 disables MODULATION OUTPUT/AUDIO INPUT.

Error 02 Refer to RF Input Attenuation and Gain for nominal input levels. Error 02 disables MODULATION OUTPUT/AUDIO INPUT.

Error 03 Refer to RF Input Attenuation and Gain for nominal input levels. Error 03 disables MODULATION OUTPUT/AUDIO INPUT.

Attenuator Measurements (Cont'd)
(Includes the SET REF key and Special Function 26)

HP-IB Program Codes

CALIBRATE on = C1
CALIBRATE off = C0
LIN results = LN
LOG results = LG
SET REF = RF
SPCL = SP
TUNED RF LEVEL = S4

Indications

Display: When the TUNED RF LEVEL key is pressed, the following responses are displayed: four dashes (----) to indicate the signal has been found, then six dashes (-----) to indicate the instrument is fine tuning to the signal, then four dashes again (----) to indicate settling.

If linear units are selected, the % annunciator is displayed. If logarithmic units are selected, the dB annunciator is displayed.

If the instrument autoranges to a range than has not been previously calibrated, the RECAL or UNCAL annunciator is displayed. Press the CALIBRATE key.

Front Panel: The LED within the S (shift) and TUNED RF LEVEL keys light. When the Blue Key is pressed, it blinks (at the current measurement rate) until the SET REF key is pressed. The LED within the SET REF key (ZERO key) will not light when pressed.

Measurement Technique

The SET REF key enables the Measuring Receiver to set a power reference to the initial level measurement at the detector. All subsequent level measurements made at that frequency (± 5 kHz) are referenced to this initial setting.

The major difference between absolute and relative tuned RF level measurements is the way the initial reference is obtained.

For absolute measurements, the initial level measurement at the detector is equated to a measurement made at the calibrated power sensor using a calibration factor. For relative measurements, the initial level measurement always uses a calibration factor of 100%.

Error Message Summary (Cont'd)

Description (cont'd)

Error 30 through Error 39. These messages are Tuned RF Level Calibration Errors that are used to indicate that some condition has not been met to enable calibration of the Tuned RF Level function. The errors can usually be cleared by readjusting the input signal, or by setting Special Functions 1 and 9 to automatic selection.

Error 40 through Error 89. These messages are Service Errors and are generated to give service information, or because a service function has been accessed and has generated a message. Service errors do not necessarily represent failures within the instrument and must be enabled to appear. Service Errors are discussed in Section VIII.



HP-IB Output Format

The HP-IB output format for errors is shown below:

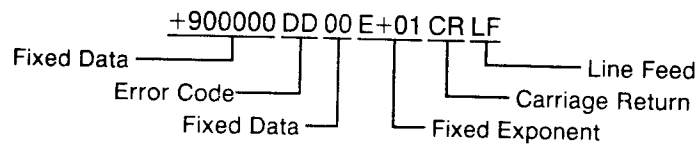

For example, Error 02 is output to the HP-IB as +9000000200E+01CRLF. Once an error has been input to the computing controller, the error code is simply derived by subtracting 9×10^{10} from the input number, then dividing the result by 1000.

Attenuator Measurements (Cont'd)
(Includes the SET REF key and Special Function 26)

Description (cont'd)

Since the relative measurement uses the same detectors and internal ranges as the absolute measurement, the absolute and relative measurement share the two calibration factors for the two internal ranges that are used to enable the instrument to measure absolute power levels from +30 dBm to -127 dBm. Therefore, when the Measurement modes are switched between relative and absolute measurements, the only recalibration necessary is for the initial reference range.

(Refer to Tuned RF Level for a more detailed description of all aspects of tuned RF level measurement technique . Refer to Tuned RF Level Calibration and Calibration Factors for a more detailed explanation regarding the derivation of calibration factors.)

Comments

Relative measurements cannot be made on absolute power levels out of the range from +30 dBm to -127 dBm.

Tune the Measuring Receiver before making any relative or absolute tuned RF level measurements.

Related Functions

Tuned RF Level Calibration and Calibration Factors
Tuned RF Level

Error Message Summary

Description

The instrument generates error messages to indicate operating problems, incorrect keyboard entries, or service-related problems. The error message is usually cleared when the error condition is removed.

Four types of error display formats exist in the Measuring Receiver:

Error : The numerical value of the error is displayed.

(--): No detectable signal falls within the IF passband. Either no signal is at the input, or the instrument cannot tune to find the applied signal. (For example, it might be manually tuned far enough away from an input signal that no power is detected in the IF.) This display is output to the HP-IB as Error 96 using the HP-IB output format described in this Detailed Operating Instruction.

(----): A signal has been detected but, for various reasons, a measurement result is not yet available. The instrument might be still completing the measurement requested, or in some cases, unable to complete a measurement because of manual settings of Special Functions. (For example, when frequency measurements are made on a low-level input signal with high AM depth, or when the RF input attenuation and gain is improperly set.) This display is never output to the HP-IB, and typically indicates a transitory state in instrument operation.

(-----): Displayed only when Synchronous Tuned RF Level measurements are made. (Refer to Tuned RF Level.) This display is never output to the HP-IB, and typically indicates a transitory state in instrument operation.

Error messages are grouped by error code as follows:

Error 01 through Error 19 and Error 90 through Error 99. These messages are Operating Errors to indicate that some condition has not been met to assure a calibrated measurement. Operating Errors can usually be cleared by a readjustment of front-panel controls (usually, the easiest way is to press AUTOMATIC OPERATION). The Disable Error Message Control Special Function (Special Function 8) can be used to selectively disable certain Operating Errors.

Error 20 through Error 29. These messages are Entry Errors which indicate that an invalid key sequence or keyboard entry has been made. These errors require that a new keyboard entry or function selection be made. Some of these error displays time out after a few seconds and then return to the current measurement.

Automatic Operation

Description

The AUTOMATIC OPERATION key configures the Measuring Receiver to automatically tune to the largest detectable input carrier (refer to RF Frequency Tuning for qualifications) and to make the measurement selected.

The AUTOMATIC OPERATION key sets Special Functions with prefixes 1 through 10 to their 0-suffix mode, disables some front-panel keys (TRACK MODE, AUTO TUNING, RANGE HOLD, DISABLE ERROR, and Blue Key), turns off many Special Functions with prefixes greater than 10, and overrides all Service Special Functions (prefixes 0, 40, or greater). The AUTOMATIC OPERATION key does not affect HP/LP FILTERS, FM DE-EMPHASIS, MEASUREMENT, CALIBRATION, SAVE CAL (including all calibration factors), DETECTOR, DISPLAY, RATIO, Limit settings (Special Function 14), or Frequency Offset Control (Special Function 27).

MODULATION OUTPUT/AUDIO INPUT is blanked temporarily during the automatic tuning process that is initiated when the AUTOMATIC OPERATION key is pressed.

Procedure

To re-enter the Automatic Operation mode, press the AUTOMATIC OPERATION key. The instrument will immediately re-tune to the input signal and make the measurement selected.

Program Code

AUTOMATIC OPERATION = AU

Indications

Display: Four dashes (----) are displayed while the instrument conducts an automatic-tuning sequence. When tuned, the instrument displays the measurement selected.

If two dashes (--) are displayed, the Measuring Receiver cannot locate the signal.

A display of six dashes (-----) only pertains to Synchronous Tuned RF Level measurements. The instrument is fine-tuning to the signal. (Refer to Tuned RF Level.)

Front panel: The LEDs within the selected functions light.

Disable Error Message Control (Cont'd)
(Includes the DISABLE ERROR key and Special Function 8)

HP-IB Program Codes

The HP-IB program codes for selectively disabling combinations of Errors 01 through 04 are provided in "Procedure".

DISABLE ERROR = B1
Clear DISABLE ERROR function = B0

Indications

Display: When the DISABLE ERROR key is pressed, the display returns to the measurement previously selected.

As the numeric code is entered, it appears on the display. When the SPCL key is pressed, the display returns to the measurement previously selected.

Front Panel: When the DISABLE ERROR key is pressed, the LED next to DISABLE ERROR and the LED within the SPCL key lights.

When one of Special Functions 8.1 through 8.8 is pressed, the LED within the SPCL key lights.

Comments

When the instrument is first powered up, or when AUTOMATIC OPERATION or INSTR PRESET is selected, Special Function 8 is placed in the automatic selection mode (8.0 SPCL).

When Error 04 is disabled, the audio autorange function ranges upward only. Thus, if a transitory peak audio signal is detected, the Measuring Receiver will increase the audio range to accommodate it but will not down range after it has passed. Audio autoranging is then prevented from interfering with other measurements such as input frequency.

Errors disabled when in the automatic selection mode may be inadvertently enabled when a manual mode is selected. For example, when measuring frequency (Error 02 through Error 04 automatically disabled). Selecting Special Function 8.1 to override a display of Error 04 would reenables Error 02 through Error 04. (The best selection would really be 8.7 SPCL; Error 01 through Error 04 disabled.)

Use the Special Display and the Special Special Display (described in Special Functions) to identify the current errors that are disabled.

Related Functions

Automatic Operation
Error Message Summary
Special Functions

Automatic Operation (Cont'd)

Comments

The instrument powers up in the Automatic Operation mode.

The AUTOMATIC OPERATION key is the easiest way to make measurements in applications where only a single carrier is present at the RF INPUT. The instrument configures itself to meet the needs of most measurement situations, and all errors preventing inaccurate displays are enabled.

The converse of the Automatic Operation mode is the RANGE HOLD key. Refer to RANGE HOLD.

The instrument cannot enter the Automatic Tuning mode when making Synchronous or Average Tuned RF Level measurements.

Related Functions

Instrument Preset
Range Hold
RF Frequency Tuning
Special Functions

Disable Error Message Control (Cont'd)
 (Includes the DISABLE ERROR key and Special Function 8)

Description (cont'd)

The following table lists the errors that are automatically disabled in each Measurement mode:

Measurement Selected	Errors Disabled When in Automatic Selection Mode (Special Function 8.0)
AM	None
FM	None
ϕ M	None
RF POWER	01, 04
FREQ	02, 03, 04
AUDIO FREQ	None
AUDIO DISTN	None
IF LEVEL	01, 02, 03, 04
TUNED RF LEVEL	02, 03, 04
FREQ ERROR	01, 02, 03, 04
SINAD (Special Function 29.0)	None
EXT AUDIO RMS LEVEL (Speical Function 30.0)	None
LO FREQUENCY (Special Function 33.0)	01, 02, 03, 04
IF FREQUENCY (Special Funicton 34.0)	01, 02, 03, 04
RF LEVEL (Special Function 35.0)	01, 04
PEAK TUNED RF LEVEL (Special Function 36.0)	02, 03, 04

Procedures

To disable Errors 01, 02, 03, and 04, press the Blue Key and DISABLE ERROR (RANGE HOLD) key.

To selectively enable or disable combinations of Errors 01 through 04, enter the Special Function code that corresponds to the condition desired, then press the SPCL key. The codes for the various conditions are provided in the following table:

Error Condition	Special Function Code	Program Code 
Automatic Selection	8.0 SPCL	8.0SP
01 disabled	8.1 SPCL	8.1SP
02 and 03 disabled	8.2 SPCL	8.2SP
01, 02, and 03 disabled	8.3 SPCL	8.3SP
04 disabled	8.4 SPCL	8.4SP
01 and 04 disabled	8.5 SPCL	8.5SP
02, 03, and 04 disabled	8.6 SPCL	8.6SP
01, 02, 03, and 04 disabled	8.7 SPCL	8.7SP
01, 02, 03, and 04 enabled	8.8 SPCL	8.8SP

Disable Error Message Control (Includes the DISABLE ERROR key and Special Function 8)

Description

When the Measuring Receiver is in its Automatic Operation mode, some measurement safeguards are selectively enabled or disabled to allow the broadest range of calibrated measurements to be displayed. Errors are displayed when these safeguards must be enabled. The safeguards can be manually disabled or enabled using Special Function 8. The DISABLE ERROR key performs the same function as Special Function 8.7 (Errors 01, 02, 03, 04 disabled).

When any errors are disabled, the quality of the signal at the output of MODULATION OUTPUT/AUDIO INPUT is not safeguarded. When all the errors are enabled, displayed results are calibrated and the output of MODULATION OUTPUT/AUDIO INPUT is entirely safeguarded.

Most combinations of Errors 01 through 04 can be disabled or enabled by the operator to modify the behavior of the instrument to meet the requirements of the measurement conditions. By entering Special Function 8.8 (which enables all errors), the Measuring Receiver can be set up as primarily a calibrated receiver.

The following table lists the error messages conveyed by Errors 01 through 04:

Error	Error Message
01	Signal out of IF range
02	Input circuits overdriven
03	Input circuits underdriven
04	Audio circuits overdriven